

**LUDLUM MODEL 44-2  
GAMMA SCINTILLATOR**

**February 2018  
Serial Number PR361009 and Succeeding  
Serial Numbers**



# **LUDLUM MODEL 44-2 GAMMA SCINTILLATOR**

**February 2018  
Serial Number PR361009 and Succeeding  
Serial Numbers**



**LUDLUM MEASUREMENTS, INC.**

**501 OAK STREET, P.O. BOX 810**

**SWEETWATER, TEXAS 79556**

**325-235-5494, FAX: 325-235-4672**



---

## **STATEMENT OF WARRANTY**

Ludlum Measurements, Inc. warrants the products covered in this manual to be free of defects due to workmanship, material, and design for a period of twelve months from the date of delivery. The calibration of a product is warranted to be within its specified accuracy limits at the time of shipment. In the event of instrument failure, notify Ludlum Measurements to determine if repair, recalibration, or replacement is required.

This warranty excludes the replacement of photomultiplier tubes, G-M and proportional tubes, and scintillation crystals which are broken due to excessive physical abuse or used for purposes other than intended.

There are no warranties, express or implied, including without limitation any implied warranty of merchantability or fitness, which extend beyond the description of the face there of. If the product does not perform as warranted herein, purchaser's sole remedy shall be repair or replacement, at the option of Ludlum Measurements. In no event will Ludlum Measurements be liable for damages, lost revenue, lost wages, or any other incidental or consequential damages, arising from the purchase, use, or inability to use product.

## **RETURN OF GOODS TO MANUFACTURER**

If equipment needs to be returned to Ludlum Measurements, Inc. for repair or calibration, please send to the address below. All shipments should include documentation containing return shipping address, customer name, telephone number, description of service requested, and all other necessary information. Your cooperation will expedite the return of your equipment.

**LUDLUM MEASUREMENTS, INC.  
ATTN: REPAIR DEPARTMENT  
501 OAK STREET  
SWEETWATER, TX 79556**

**800-622-0828      325-235-5494  
FAX 325-235-4672**

---

---

---

## Table of Contents

---

<b><i>Introduction</i></b>	<b>1</b>
<b><i>Unpacking and Repacking</i></b>	<b>2</b>
<b><i>Specifications</i></b>	<b>3</b>
<b><i>Operating Procedures</i></b>	<b>4</b>
<b><i>Safety Considerations</i></b>	<b>5</b>
<b><i>Parts List, Drawings and Diagrams</i></b>	<b>6</b>
<b><i>Energy Response Curve</i></b>	<b>10</b>

## Introduction

---

The Model 44-2 sodium iodide (NaI) gamma scintillator is primarily used for detecting low levels of gamma radiation in the range of 20 keV–1.5 MeV. It consists of a 2.54 x 2.54 cm (1 x 1 in.) (Dia. X thickness) NaI crystal coupled to a photomultiplier tube and is housed in a 0.157 cm (0.062 in.) thick aluminum housing. The front entrance window has a total thickness of 2.3 mm (0.09 in.) of aluminum. The detector is energy dependent, over-responding by a factor of 10 or greater in the 100keV range and under-responding by a factor of 0.5 above 1 MeV when normalized to  $^{137}\text{Cs}$ .

The Model 44-2 will operate with any Ludlum instruments or equivalent instruments that provide 500–1200 volts. The recommended instrument input sensitivity is approximately 10 mV or higher.

Some common applications for this detector include background radiation monitoring, low-level radiation detection, and spectrum analysis when used in conjunction with a single- or multi-channel analyzer.



*Model 44-2*

**Note:**

The detector does not contain any consumable materials.



**Note:**

If the detector is used in a manner not intended by the manufacturer, the detector may not function properly.

## **Unpacking and Repacking**

---

Remove the calibration certificate or detector functional check certificate and place it in a secure location. Remove the detector(s) and accessories (if applicable) and ensure that all items listed on the packing list are in the carton. If multiple detectors are included, refer to the calibration certificates for serial number (SN) matches.

To return an instrument or detector for repair or calibration, provide sufficient packing material to prevent damage during shipment, and affix appropriate warning labels to promote careful handling.

Every returned instrument must be accompanied by an **Instrument Return Form**, which can be downloaded from the Ludlum website at [www.ludlums.com](http://www.ludlums.com). Find the form by clicking the “Support” tab and selecting “Repair and Calibration” from the drop-down menu. Then choose the appropriate Repair and Calibration division where you will find a link to the form.

## Specifications

---

**Compatible Instruments:** general-purpose survey meters, ratemeters and scalers

**Sensitivity:** typically 175 cpm per  $\mu\text{R/hr}$  ( $^{137}\text{Cs}$  gamma)

**Dead Time:** approximately 10  $\mu\text{s}$ , typically limits linear range to 5 mR/hr (50  $\mu\text{Sv/h}$ ) with non-corrected measurements, or to 50 mR/hr (500  $\mu\text{Sv/h}$ ) with electronics equipped with dead time correction

**Energy Response:** energy dependent

**Background:** 1800 cpm

**Operating Voltage:** 500–1200 volts

**Dynode String Resistance:** 100 megohm

**Connector:** series "C" (others available)

**Scintillator:** 2.5 x 2.5 cm (1 x 1 in.) Dia. x thickness

**Tube:** 2.9 cm (1.1 in.) diameter magnetically shielded photomultiplier

**Efficiency (4  $\pi$ ):**  $^{125}\text{I}$  is 7%;  $^{57}\text{Co}$  is 10%;  $^{137}\text{Cs}$  is 3%;  $^{60}\text{Co}$  is 3%

**Construction:** aluminum housing with beige powder-coat finish

**Temperature Range:** -15 to 50  $^{\circ}\text{C}$  (5 to 122  $^{\circ}\text{F}$ ); may be certified for -40 to 65  $^{\circ}\text{C}$  (-40 to 150  $^{\circ}\text{F}$ )

**Size:** 5.1 x 18.5 cm (2 x 7.3 in.) (Dia. x L)

**Weight:** 0.5 kg (1 lb)

## Operating Procedures

---

### CONNECTING TO AN INSTRUMENT

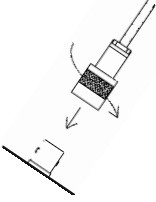

Connect one end of the cable provided to the detector by firmly pushing the connector together while twisting clockwise one quarter of a turn until latched. Repeat the process in the same manner with the other end of the cable and the instrument.

### TESTING THE DETECTOR

1. Ensure the instrument high voltage (HV) is at the proper setting for the detector.
2. Connect the detector to the instrument and check for a proper background reading (typically 1.4-2.6 kcpm or 8-15  $\mu\text{R/hr}$ ).
3. Expose the detector to a check source and verify that the instrument indicates within 20% of the check source reading from the last calibration. Alternatively, expose the detector to a source of known value and verify that the detector detects greater than or equal to the efficiency listed in the specification section of this manual.
4. Instruments and detectors that meet these criteria are ready for use. Failure to meet these criteria may indicate a malfunction in the detector.

## **Safety Considerations**

---

### **ENVIRONMENTAL CONDITIONS FOR NORMAL USE**

1. Indoor or outdoor use (in a dry environment)
2. No maximum altitude
3. Temperature range of -20 to 50 °C (5 to 122 °F); May be certified for operation from -40 to 65 °C (-40 to 150 °F).
4. Maximum relative humidity of less than 95% (non-condensing)
5. Pollution Degree 3 (as defined by IEC 664)

(Occurs when conductive pollution or dry nonconductive pollution becomes conductive due to condensation. This is typical of industrial or construction sites.)

### **CLEANING INSTRUCTIONS AND PRECAUTIONS**

The detector may be cleaned externally with a damp cloth, using only water as the wetting agent. Do not immerse the instrument in any liquid. Observe the following precautions when cleaning:

1. Turn the instrument electronics OFF.
2. Allow the instrument to sit for one minute.
3. Disconnect the detector cable before cleaning the detector.

## Parts List, Drawings and Diagrams

---

### Model 44-2 Gamma Scintillator

<u>Reference</u>	<u>Description</u>	<u>Part Number</u>
UNIT	Completely Assembled Model 44-2 Alpha-Beta-Gamma Detector	47-1532
1 EA	DETECTOR BODY	2002-084-01
1 EA	END CAP	7002-505
1 EA	2.5 x 2.5 cm (1 x 1 in.) NaI CRYSTAL	40-5154
1 EA	1.125 in. TUBE SOCKET ASSY	01-5742
1 EA	TUBE SHIELD	40-4006
1 EA	CONNECTOR, UG 706/U	4478-011
1 EA	EJ560-1.10 × .080 OPT PAD	01-5786
**	FOAM	14-5873
1 EA	O-RING	16-8317
4 EA	SCREWS	17-8811
1 EA	LUG	18-8766
8 EA	SPONGE	7002-029-05
1 EA	SPONGE 4-P BS	7002-065-04
11.4 cm (4.5 in.)	TEFLON WIRE	21-8993
11.4 cm (4.5 in.)	# 24 WIRE	21-9558

# Model 44-2 Gamma Scintillator

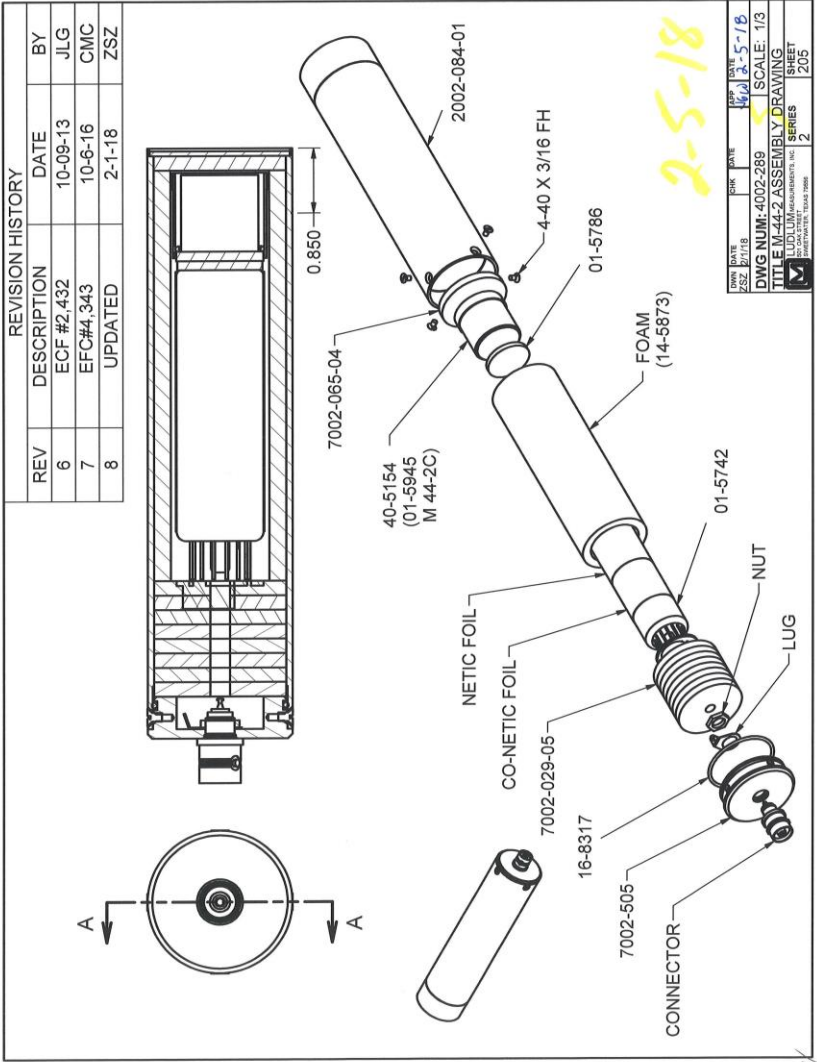

DATE	REV	BY	APP	SCALE
10/18	1	ZSZ	JLG	1:1
DWG NUM: 4002-269				
TITLE: M-44-2 ASSEMBLY DRAWING				
LUDLUM MEASUREMENTS, INC.				
SERIES: 2				
SHEET: 205				

*Model 44-2 Gamma Scintillator*

---

<u>Reference</u>	<u>Description</u>	<u>Part Number</u>
------------------	--------------------	--------------------

**3.8 cm (1.5 in.) Tube Socket Board**

1 EA	CIRCUIT BOARD	5002-370
1 EA	CAP 0.01 $\mu$ F 2kv	04-5525
11 EA	RES 10 M, $\frac{1}{4}$ W, 1%	12-7996
1 EA	RES 1 M, $\frac{1}{4}$ W, 1%	12-7844

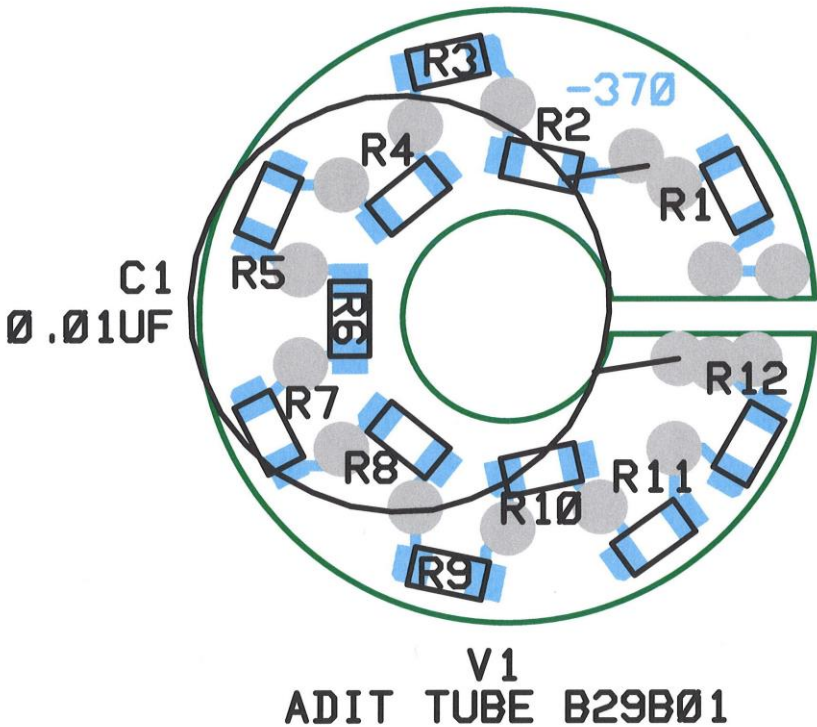

**3.8 cm (1.5 in.) Tube Socket Board - Schematic**

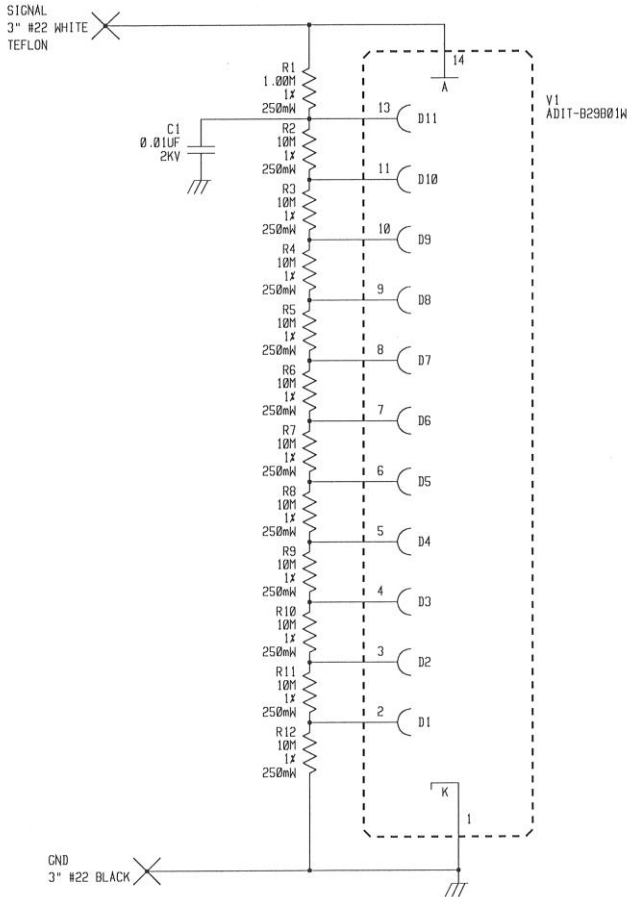

UPDATED	-	LUDLUM MEASUREMENTS INC.			
DR	CKB	09-JUL-93	TITLE : 1.125" VOLTAGE DIVIDER		
DSCN	LL	09-JUL-93	BOARD# 5002-370		
APPD	<i>MS</i>	<i>MS/HC</i>	SIZE	MODEL	SHEET
NEXT HIGHER ASSY.			C	1.125"	243
10:31:56		14-May-07	SB002370		SHEET 1 OF 1



### Energy Response for Ludlum Model 44-2

