

**LUDLUM MODEL 3500-1000
INSTALLATION MANUAL**

March 2006
Serial Number 150001
and Succeeding Serial Numbers



LUDLUM MEASUREMENTS, INC.
501 OAK ST., P.O. BOX 810
SWEETWATER, TX 79556
325/235-5494 FAX: 325/235-4672

STATEMENT OF WARRANTY

Ludlum Measurements, Inc. warrants the products covered in this manual to be free of defects due to workmanship, material, and design for a period of twelve months from the date of delivery. The calibration of a product is warranted to be within its specified accuracy limits at the time of shipment. In the event of instrument failure, notify Ludlum Measurements to determine if repair, recalibration, or replacement is required.

This warranty excludes the replacement of photomultiplier tubes, G-M and proportional tubes, and scintillation crystals which are broken due to excessive physical abuse or used for purposes other than intended.

There are no warranties, express or implied, including without limitation any implied warranty of merchantability or fitness, which extend beyond the description of the face there of. If the product does not perform as warranted herein, purchaser's sole remedy shall be repair or replacement, at the option of Ludlum Measurements. In no event will Ludlum Measurements be liable for damages, lost revenue, lost wages, or any other incidental or consequential damages, arising from the purchase, use, or inability to use product.

RETURN OF GOODS TO MANUFACTURER

If equipment needs to be returned to Ludlum Measurements, Inc. for repair or calibration, please send to the address below. All shipments should include documentation containing return shipping address, customer name, telephone number, description of service requested, and all other necessary information. Your cooperation will expedite the return of your equipment.

**LUDLUM MEASUREMENTS, INC.
ATTN: REPAIR DEPARTMENT
501 OAK STREET
SWEETWATER, TX 79556**

**800-622-0828 325-235-5494
FAX 325-235-4672**

TABLE OF CONTENTS

1. INSTALLATION OF RADIATION DETECTION SYSTEMS	4
2. INSTALLATION INSTRUCTIONS AND DRAWINGS	5
2.1 Parts List	5
2.2 Detector Mounting Bracket Installation	6
2.3 Electronics Mounting Bracket Installation	6
2.4 Detector and Infrared Sensor Installation	7
2.5 Electronics Installation	8
2.6 Initial Instrument Check	9
2.7 Vehicle Sensor and Alarm Check	9

1. INSTALLATION OF RADIATION DETECTION SYSTEMS

INTRODUCTION -- Your Ludlum Measurements, Inc. gate monitor is designed to protect you from radiation and costs incurred from the radiation. To be effective, though, the system must be installed correctly and the operators must be trained. The system is designed to be automatic, with very little operator intervention. Ludlum Measurements has personnel to help with the installation and to train users on radiation safety and equipment use.

Each vehicle should drive slowly through the detectors. When it is completely through the detectors, the microprocessor-based electronics will take a couple of seconds to decide if any excess radiation was present. When excess radiation is present, the alarm will be activated to alert the operators. A common practice is to run the vehicle through a second time to ensure that the gate monitor is activated twice. Then, portable detectors are usually used to locate the "hot" or radioactive material.

The following provide some general tips:

Protection -- A scrap yard is a rough environment and not everyone is a good driver. Protect the gate monitors because they are expensive to rebuild. Protection includes crash barriers, railings, and curbs if possible.

Background Radiation -- Survey the site prior to putting in the gate monitor. Asphalt can be made with naturally-occurring radioactive material (NORM), which can disrupt the sensitivity of the system. Also, don't pile NORM scrap next to the gate monitor.

Slow the Traffic -- Traffic just can't speed through and be adequately scanned. Any gate monitor has a frightening loss of sensitivity if the truck zooms through faster than 5 mph. We suggest a stop sign prior to the monitor, speed bumps, and a speed limit of 2-3 mph.

Training -- A system depends upon trained personnel to operate correctly. Personnel must be trained to use the equipment properly, respond to radiation alarms, identify the problem, and initiate the correct safety procedures if the radiation is above the measuring limits of the portable detector. Training should apply to everyone within the yard so that secondary checks may detect radioactive material. For example, if a lead-shielded source makes it through the gate monitor without detection, maybe someone who was trained might notice a radiation symbol or that there is an inordinate amount of lead in a small container.

MODEL 3500-1000 RADIATION MONITOR SYSTEM

2. INSTALLATION INSTRUCTIONS AND DRAWINGS

The following instructions are for the standard installation where the system is located at the weigh scales of a facility. It can be configured for other areas if required.

2.1 Parts List for Standard Installation

The following list consists of all necessary materials that have been shipped with the Model 3500-1000 Gate Monitor System. Please verify that all parts have been included. If any parts are missing, contact LMI at 1-800-622-0828 and ask for customer service in the Sales Department. We will be glad to send you any parts that have been mistakenly left out.

<u>PART</u>	<u>PART NO.</u>	<u>QUANTITY</u>
Model 3500-1000 Electronics with Key	4384-297	1
Model 3500-1000 Electronics Mounting Bracket Kit	4384-142	1
Includes: Mounting Brackets	7384-026	2
5/16 - 18 X 1" Screws	17-8580	4
5/16 Flat Washers	20-9049	8
5/16 Lock Washers	20-9121	4
5/16 Hex Head Nuts	20-9120	4
Model 44-128 Detectors with Protective Housings and Hardware	47-2957	2
Detector Cables (Soler-on BNC, 200')	8303-668	2
Infrared Sensor Set with Cable	4384-307	1
Red Strobe with Cable	4384-143	1
Check Source	01-5231	1
22-gauge wire nuts	20-9142	10

The following items will also need to be obtained by the user to complete the system installation.

<u>PART</u>	<u>QUANTITY</u>
10" channel or I-beam, approximately 13' long. (Detector mounts)	2
5" pipe, approximately 13' long (Guard posts) or equivalent	4
1" steel plate (8 1/2" x 6')	2
1 1/2" rigid conduit with weather-tight fittings	The amount of conduit is determined by the distance from the electronics and the detectors.
1/2" flexible weathertight conduit with fittings (4 ea. straight fittings; 2 ea. 90° fittings)	Approximately 15' - 20'
Concrete mix (for optional curb, add 10 yards)	Approximately 1 yard
1" Uni-Strut, 7' long	2

2. INSTALLATION INSTRUCTIONS AND DRAWINGS

2.2 Detector Mounting Bracket Installation

1. Three detector brackets attach to the detector stand using 1/2" bolts. Alternatively, the detector can be mounted to 4"-6" pipe, using the clamps provided.
2. The detector is then attached to the brackets using 3 stainless steel clamps. Be sure that the LUDLUM label faces away from the stand.

2.3 Electronics Mounting Bracket Installation

1. Unlock and open the front panel of the Model 3500-1000 electronics using the key that is provided.
2. Locate the four mounting holes in the bottom corners of the box and place one 5/16 - 18 X 1" screw in each hole.

NOTE: Be careful not to drop the screws into the electronics or damage the circuitry in any way. Many of the parts are delicate and cannot withstand much abuse.

3. Place a mounting bracket on each side of the electronics so that the flange faces out. Secure in place with the lock washers and nuts.
4. Close and lock the electronics front panel and place the key in a secure place. The instrument is now ready for installation.

2. INSTALLATION INSTRUCTIONS AND DRAWINGS

2.4 Detector and Infrared Sensor Installation

To prepare the site for system installation, conduit will need to be run from the building where the electronics will be located to both sides of the scale or location of the detectors. In addition, three 1-ft. diameter X 3-ft. deep holes will need to be dug according to the installation drawings. The conduit should be run so that it meets with the center hole on each side of the vehicle passageway.

1. Place one 10" I-beam or equivalent in the center hole on each side of the scale on which to mount the detectors and infrared sensors.
2. Run the 1 1/2" rigid conduit from the building to the center hole on each side of the scale so that the end of the conduit is approximately 2 ft. above the surface of the ground. The junction box will be mounted to the conduit; therefore, the conduit length should correspond to desired mounting position.
3. Fill the center holes with concrete. Make sure that the poles are supported so that they remain perpendicular to the ground while the concrete is setting.
4. Place one 5" pole in each of the four remaining holes and fill the holes with concrete, making sure to support the poles so that they remain perpendicular to the ground while the concrete is setting.
5. The optional curb will also help protect the system. It requires approximately 10 yards of concrete.

NOTE: The concrete will need to set for approximately 24 - 48 hours to insure stability. If the weather is wet or cold, drying times may be longer.

6. Mount one detector on each 10" channel of I-beam using the clamps provided. Position the detectors so that the front (*indicated by the sticker*) of the detectors face the vehicle or load.
7. Mount the Uni-Strut onto the 10" I-beam as shown in the installation drawings. Mount the infrared sensors onto the Uni-Strut and align them by using the sights on the sensor shields. A laser pointer can also be used to aid the process.

NOTE: The infrared receiver has a switch on the top that should be set to "Dark On." This means that the receiver is activated any time a truck blocks the beam from the transmitter to the receiver. The sensors are configured so that one side will be higher than the other. Loosen each sensor and use the sight provided to adjust the sensor until you can see the other one through the sight. Each Sensor will need to be pointed at the other sensor for correct operation.

8. Mount the junction box to the 1 1/2" conduit on each side of the scale in desired location for added support. The junction box may be mounted or secured to one of the following, as appropriate: 10" channel, I-beam, or curb.
9. Run the infrared sensor cables through a piece of 1/2" weather tight flexible conduit from the sensor to the junction box.
10. Now pull the two cables from the scale house back into each side of the scale. Reconnect the wires of the infrared (gray) cable inside the junction box, using the wire nuts provided. Connect each detector to the junction box using 1/2" flexible weather-tight conduit. Pull the detector cable through the junction box to the detector. Solder the BNC connector to the cable and connect it to the internal detector BNC coupling.

MODEL 3500-1000 RADIATION MONITOR SYSTEM

2. INSTALLATION INSTRUCTIONS AND DRAWINGS

2.5 Electronics Installation

1. With the electronics mounting brackets attached to the electronics, mount the unit on the wall where it will be convenient for the user to reset the system in the event of an alarm.
2. Locate the cables for each detector and the infrared sensor.
3. Connect the cable for the detector on the left side of the vehicle passageway to the connector labeled "CHANNEL 1."
4. Connect the remaining detector cable to the connector labeled "CHANNEL 2."
5. Connect the red strobe cable to the connector labeled "RELAY OUT." The strobe can be placed outside the building, or in other locations within 50' of the electronics.
6. Connect the infrared sensor cable to the connector labeled "CONTROLS."
7. Connect the power cord to the connector labeled "115 VAC" (or 220 VAC).
8. Turn the power switch to the "ON" position and proceed with the checkout procedures on the following page.

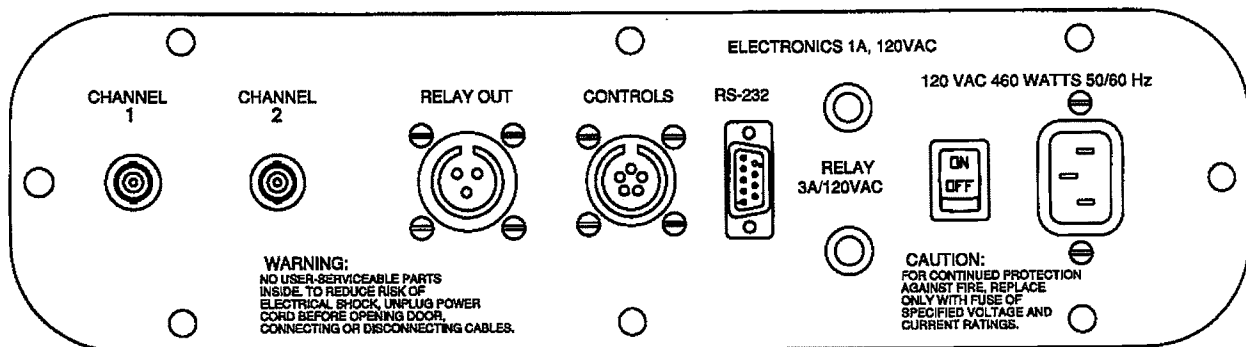

2. INSTALLATION INSTRUCTIONS AND DRAWINGS

2.6 Initial Instrument Check

Once the Model 3500-1000 Gate Monitor has been properly installed, it should be ready for normal operation. The following procedures will take you through the initial checkout of the instrument and its operation.

NOTE: Operating procedures can be found in a separate manual: "Ludlum Model 3500-1000 Radiation Detector System."

1. Insure that detectors, vehicle sensors, and any optional accessories are properly connected to the main electronics (*i.e. printer, computer, strobes, horns, etc*).
2. Confirm that the main electronics is connected to 110 VAC (*220 VAC if applicable*).
3. Flip the power switch on the connector plate to the ON position.

NOTE: When this is done, the meter should momentarily deflect to full scale, and all of the lights on the electronics will light up for approximately one second. The meter will then begin indicating a reading from the detectors. The lights should all go off with the exception of the POWER OK light which will stay on and the SYSTEM OK light which will flash for approximately fifteen seconds while the instrument obtains a background reading and completes a diagnostic check of all parameters. The SYSTEM OK light will then come on and stay on.

2.7 Vehicle Sensor and Alarm Check

For the next part of the checkout it is necessary to use the check source that is provided with the instrument to check the alarm function for proper operation.

1. You should get the source and place it so that it is located on the Ludlum Measurements, Inc. sticker on the detector while placing the other hand in front of the infrared sensor. Hold it there for approximately 5 seconds and then remove the source from the detector and your hand from in front of the sensor.

NOTE: The alarm circuit should activate causing the audio to come on and the alarm lamp to light up. The ALARM1 or ALARM2 lamp should also illuminate, depending on which detector is being tested. Any remote alarm indicators should also be activated (*i.e. strobe or horn if applicable*).

2. Press the AUDIO ACKNOWLEDGE button. The audio on the electronics should quit, but the alarm lights and remote indicators will still be activated.
3. Press the ALARM RESET button. All alarm indicators should go off, including any remote strobe or horn that is connected (*if applicable*).

Repeat this procedure for the other detector. Once completed successfully, the system is ready for normal operation.

Note: This procedure should be done periodically. It is suggested that it be done at least on a weekly basis.

REV #	ALTERATIONS	DATE	BY
1	VALID	2-26-03	JGV
2	ADDED GROUND ROD	3-23-05	CMC

1" [25.4mm] STEEL PLATE

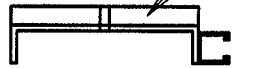

TOP VIEW OF CHANNEL

10" [254.0mm] CHANNEL
C10x15.3
or C10x20

Ø0.500 [Ø12.70mm]

12 [304.80mm]

12 [304.80mm]

86 [2184.40mm]

62 [1574.80mm]

38 [965.20mm]

5 [127.00mm]

36 [914.40mm]

36 [914.40mm]

84 [2133.60mm]

120 [3048.00mm]

GROUND ROD

CRASH BARRIER
6" [152.4mm] x
0.25 [6.35mm] WALL
SQ TUBING
OR 5" [127mm] PIPE

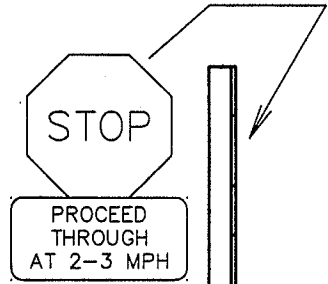

CONCRETE (3000 PSI)
SHOULD EXTEND
36" [914.4mm] BELOW
GROUND LEVEL

UNISTRUT
WELDED
TO SIDE

12 [304.80mm]

SEE ALSO SHEETS
384 X 311 B,C,D,E,F

The detectors weigh approximately
70 lbs.

DWN DATE CMC 7-18-05	CHECKED	APPROVED JGV 7-18-05
TITLE: M 3500-1K LOOKING AT DETECTOR		
LUDLUM MEASUREMENTS, INC. 801 6th STREET EASTWATER, TEXAS 75840	SERIES 384	SHEET 311A

REV #	ALTERATIONS	DATE	BY
	VALID	7-17-98	JGW

ACTIVE AREA
OF DETECTOR

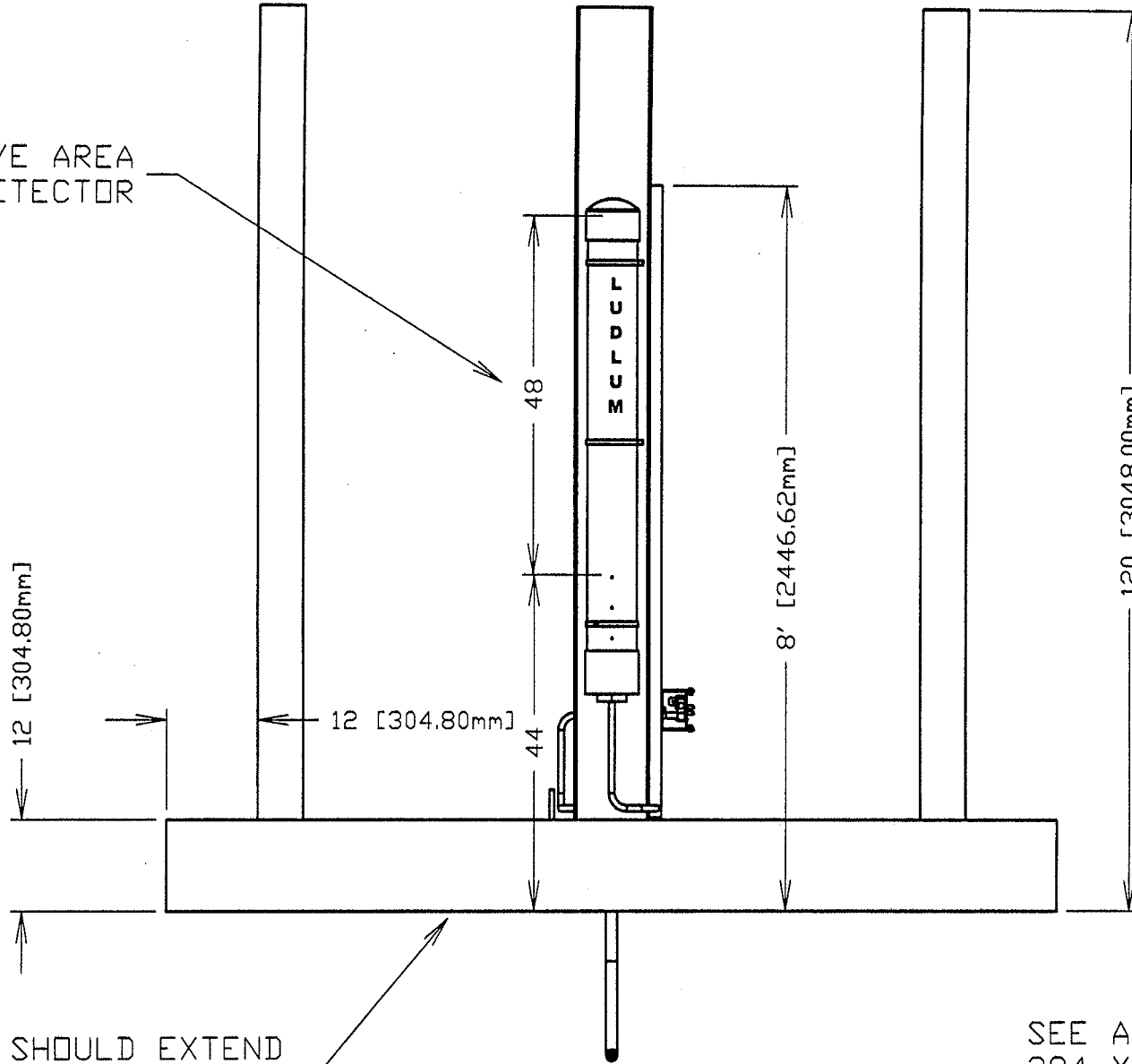

CONCRETE SHOULD EXTEND
36" BELOW GROUND LEVEL

SEE ALSO SHEETS
384 X 311 A,C,D,E,F

DWN JGW	DATE 7-18-05	CHECKED	APPROVED JGW 7-18-05
TITLE: M 3500-1K LOOKING AT DETECTOR			
LUDLUM HEARNDEN, INC. ONE DAK STREET EVANSTON, ILLINOIS 60201		SERIES 384	SHEET 311B

REV #	ALTERATIONS	DATE	BY
	VALID	03-22-00	TJR

1" STEEL PLATE
 10" WIDE FOR 10" CHANNEL
 8.5" WIDE FOR 10" I-BEAM
 APPROX. 68" LONG, MOUNT BOTTOM
 EDGE 27" FROM GROUND OR
 15" FROM TOP OF CURB

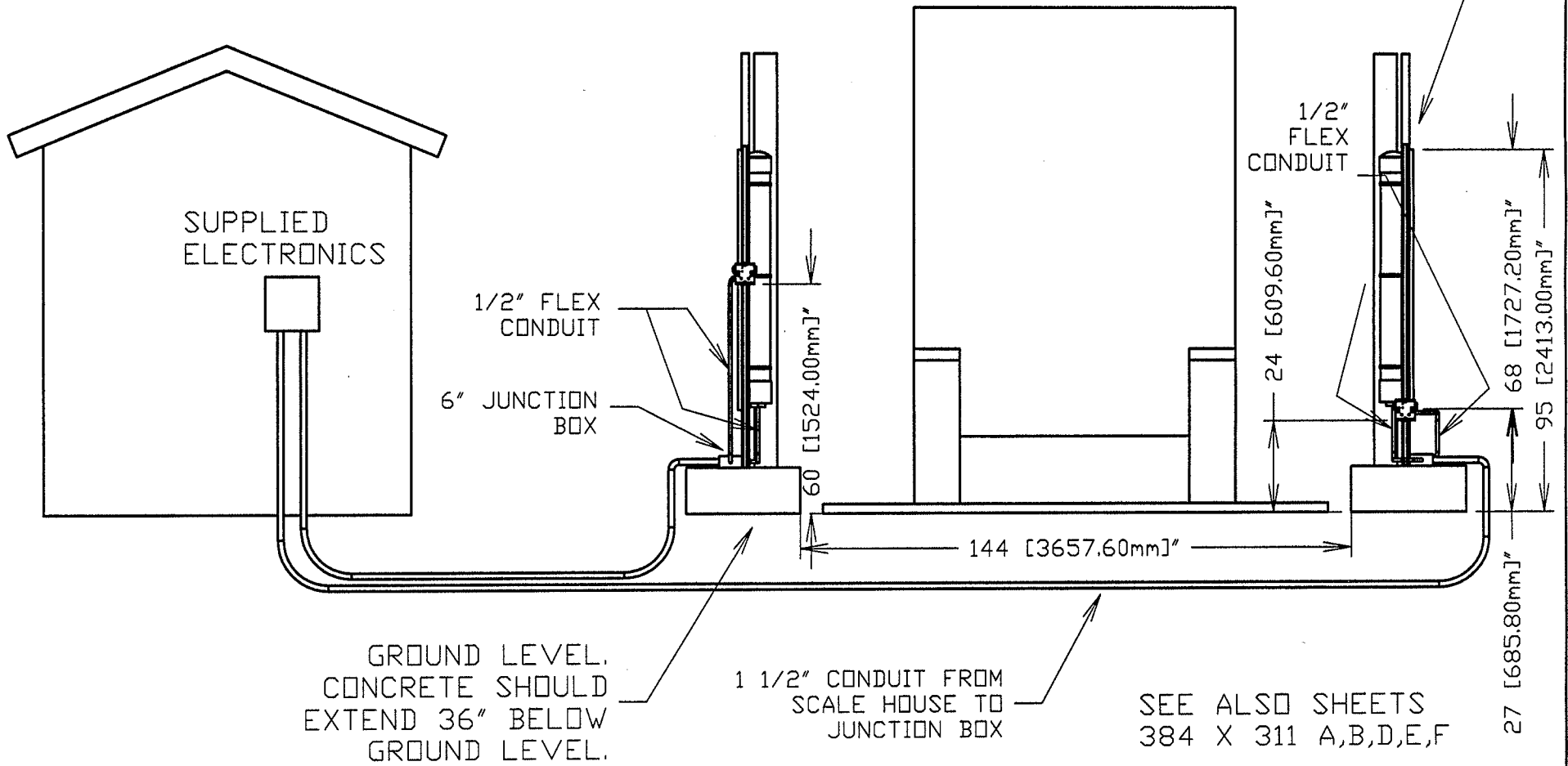

DWN TJR	DATE 7-18-05	CHECKED JW	APPROVED JW 7-18-05
TITLE: M 3500-1K LOOKING AT SCALE			
LUDLUM MEASUREMENTS, INC. 501 ONE STREET EVANSTON, ILLINOIS 60201		SERIES 384	SHEET 311C

REV #	ALTERATIONS	DATE	BY
	VALID	7-17-98	JGW

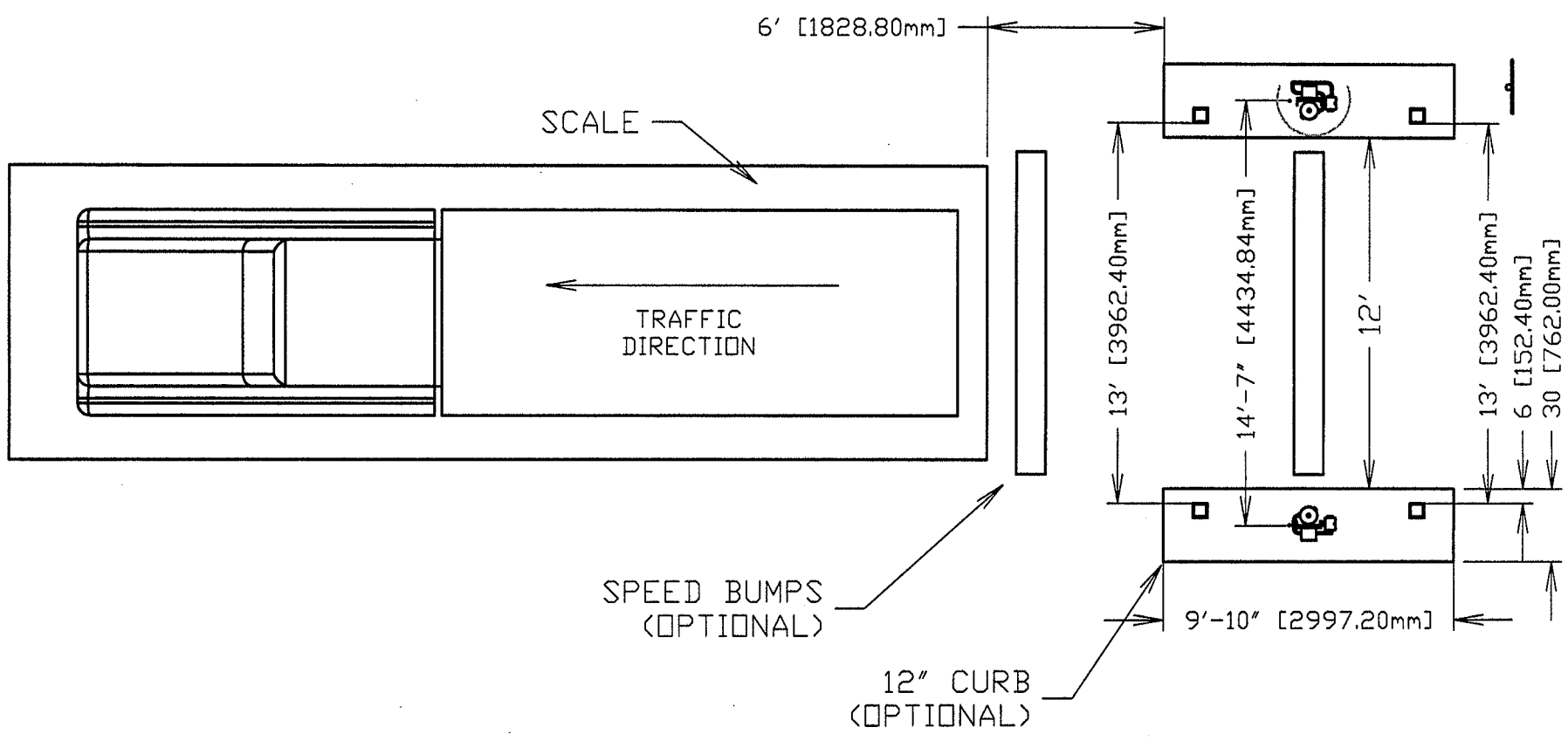

SEE ALSO SHEETS
384 X 311 A,B,C,E,F

DWN DATE JGW 7-18-05	CHECKED	APPROVED Jgw 7-18-05
TITLE: M 3500-1K AERIAL VIEW		
LUDLUM REMEDIATION, INC. ONE DAK STREET EVARTON, TEXAS 75626	SERIES 384	SHEET 311D

REV #	ALTERATIONS	DATE	BY
	VALID	7-17-98	JGW

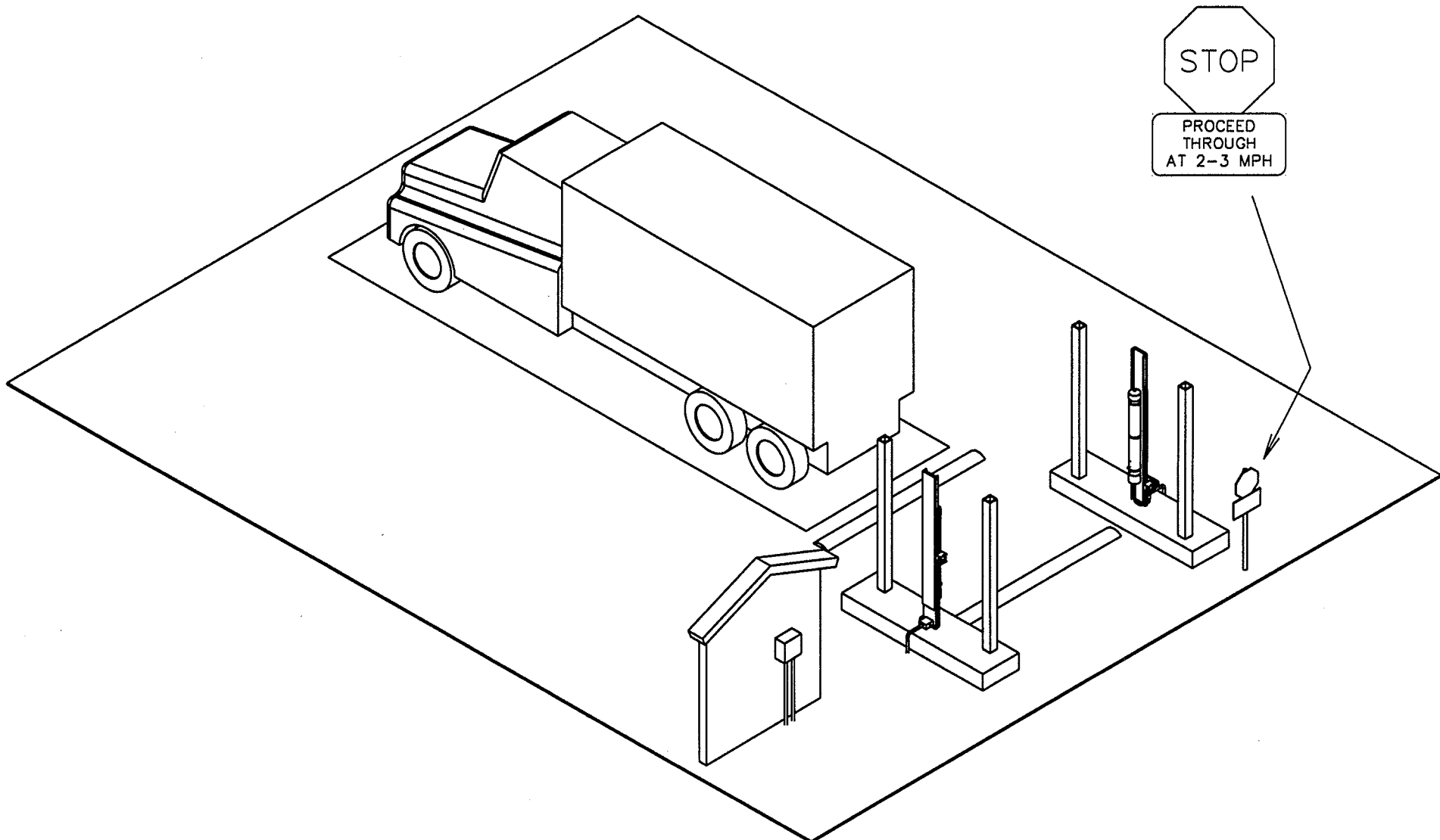

STOP

PROCEED THROUGH AT 2-3 MPH

SHOWN WITH OPTIONAL CURB AND SPEED BUMPS

SEE ALSO SHEETS
384 X 311 A,B,C,D

OWN	DATE	CHECKED	APPROVED
JGW	7-17-98	JGW 7-17-98	BLM 9-24-98
TITLE: M 3500-1K ISO VIEW			
 LUDLUM MEASUREMENTS, INC. 501 DAK STREET SUGG WATERS, TEXAS 79556		SERIES 384	SHEET 311E

REV #	ALTERATIONS	DATE	BY
	VALID	9-7-98	JGW

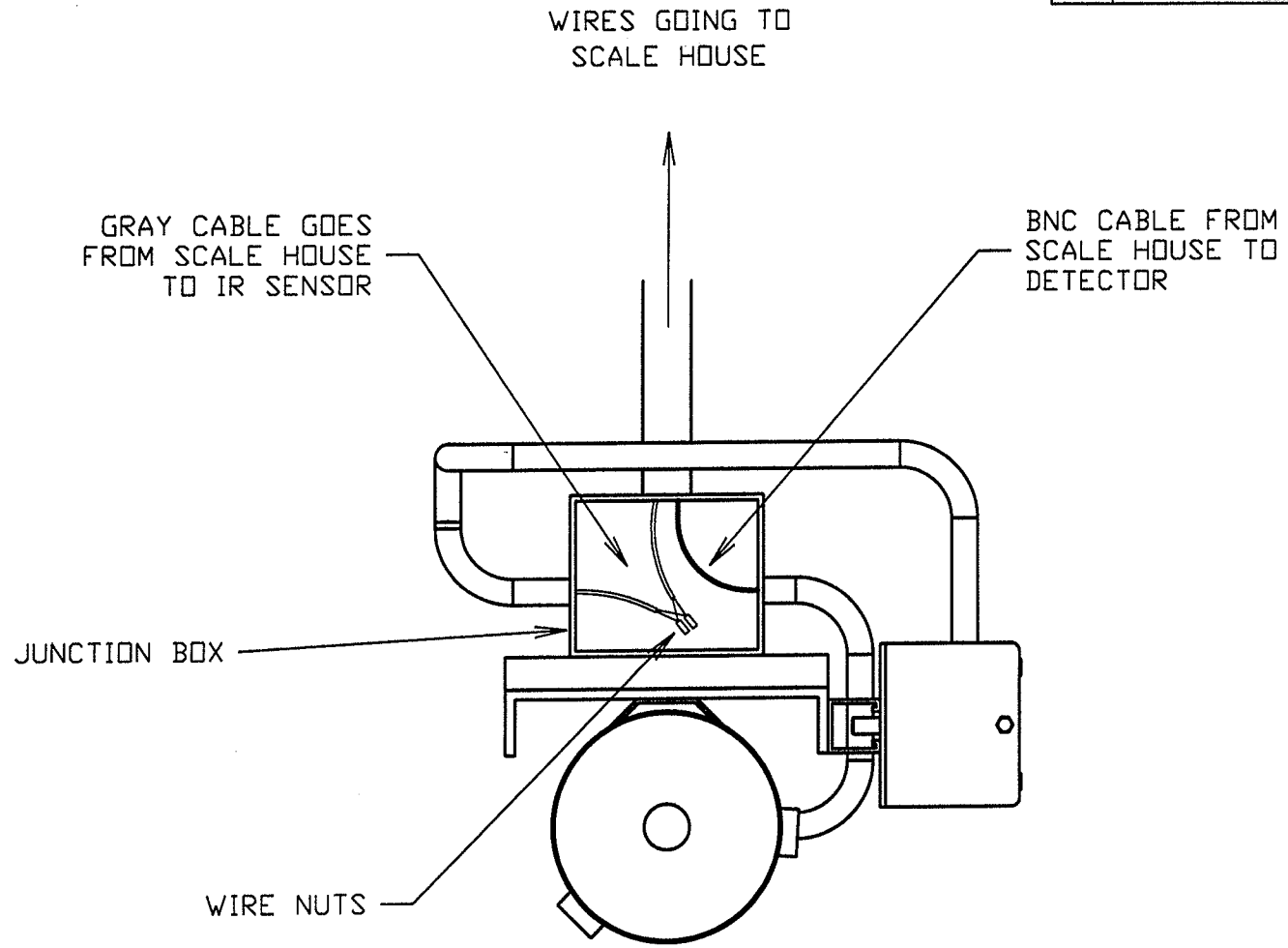

SEE ALSO SHEETS
384 X 311 A,B,C,D,E

DWN JGW	DATE 9-7-98	CHECKED RSP	APPROVED RSP
TITLE: M 3500-1000 CABLE ROUTING			
LUDLUM MEASUREMENTS, INC. 501 ONE STREET EVINGTON, TEXAS 75526		SERIES 384	SHEET 311F

REV #	ALTERATIONS	DATE	BY
	VALID	6-18-98	JGW
2	ECF# 1,646	12/10/03	CLW

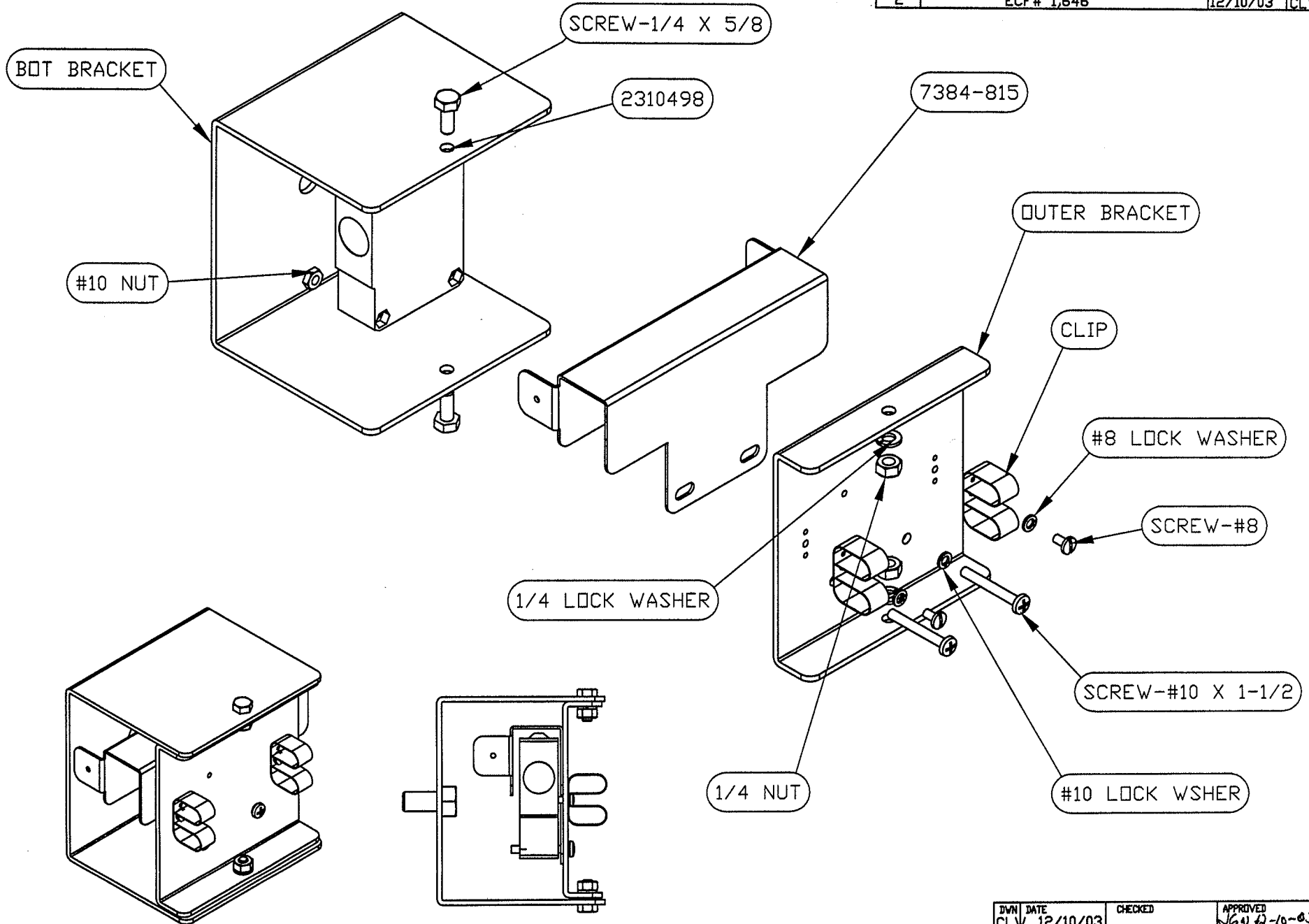

DWN	DATE	CHECKED	APPROVED
CLW	12/10/03		JGW 12-10-03
TITLE: M 3500-3K IR UNISTRUT BRKTS			
 LUDLUM MEASUREMENTS, INC. 391 DAK STREET SWEETWATER, TEXAS 75556		SERIES	SHEET
		384	307

MODEL 3500, 3523 INFRARED CABLE WIRE-UP

SICK OPTO-ELECTRONIC SENSORS
 WS260-U230 IS THE TRANSMITTER
 WE260-P230, WE260-F230 OR THE
 WE260-F270 CAN BE THE RECEIVER.

WE260-S270 MUST HAVE
 RED JUMPER BETWEEN 1 & 5

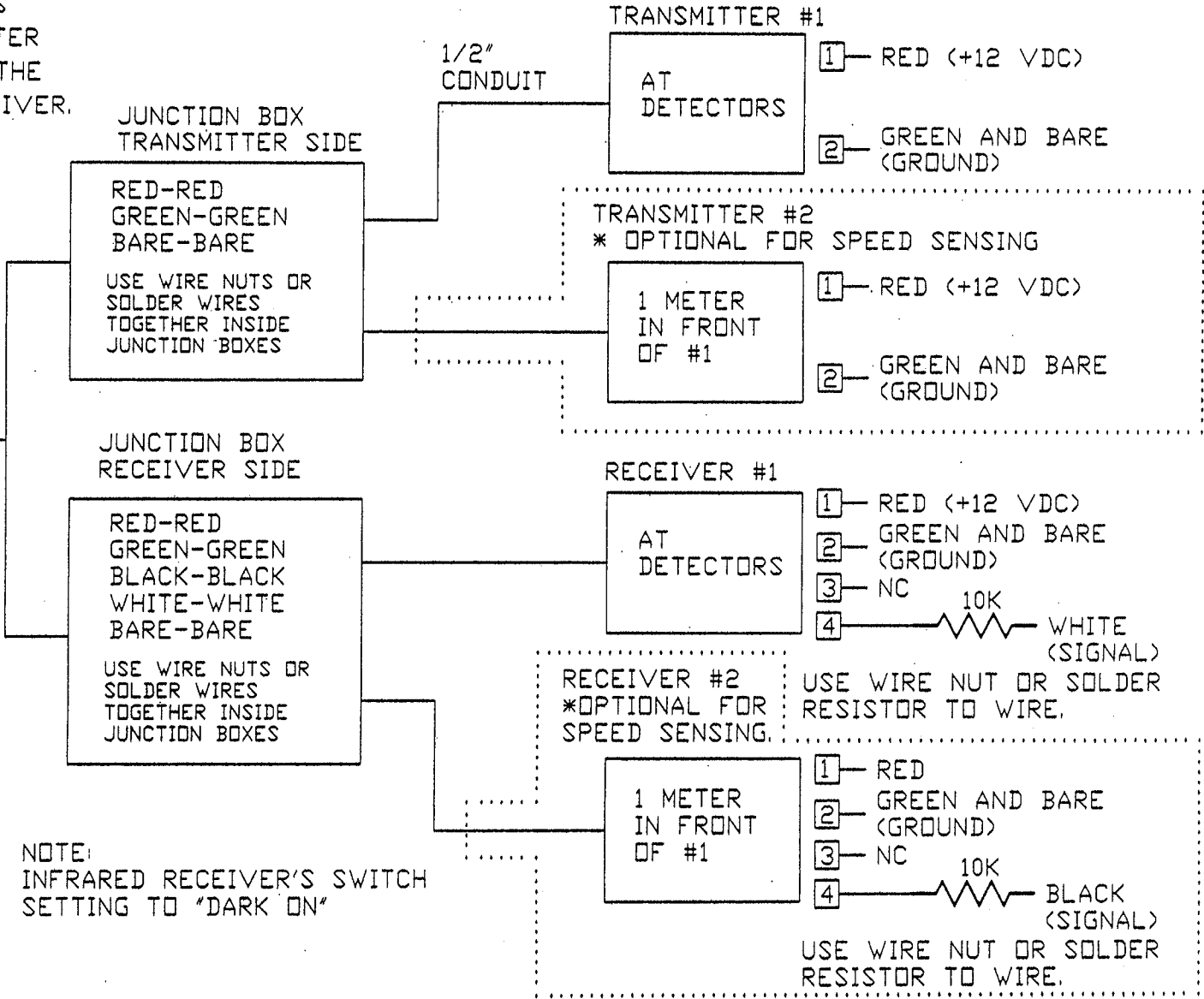
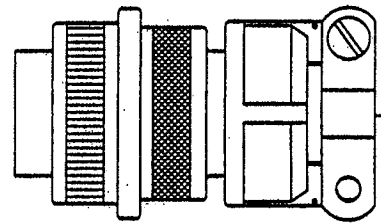

NOTE:
 INFRARED RECEIVER'S SWITCH
 SETTING TO "DARK ON"

PART NO: N/A			
DWN	DATE	CHECKED	APPROVED
CMC	2-20-04		123 20 Feb 04
TITLE: M 3500,3523			
LUDLUM MEASUREMENTS, INC. 501 OAK STREET SWEETWATER, TEXAS 75586		SERIES 384	SHEET 151