

**LUDLUM MODEL 215 AND MODEL 215-20
ALPHA FRISKER AND
CHARGING/CALIBRATION STAND**

September 2024

**Serial Number PR359548 and Succeeding
Serial Numbers**

**LUDLUM MODEL 215 AND MODEL 215-20
ALPHA FRISKER AND
CHARGING/CALIBRATION STAND**

September 2024

**Serial Number PR359548 and Succeeding
Serial Numbers**



LUDLUM MEASUREMENTS, INC
501 OAK STREET, P.O. BOX 810
SWEETWATER, TEXAS 79556
325-235-5494, FAX: 325-235-4672

STATEMENT OF WARRANTY

Ludlum Measurements, Inc. warrants the products covered in this manual to be free of defects due to workmanship, material, and design for a period of twelve months from the date of delivery. The calibration of a product is warranted to be within its specified accuracy limits at the time of shipment. In the event of instrument failure, notify Ludlum Measurements to determine if repair, recalibration, or replacement is required.

This warranty excludes the replacement of photomultiplier tubes, G-M and proportional tubes, and scintillation crystals which are broken due to excessive physical abuse or used for purposes other than intended.

There are no warranties, express or implied, including without limitation any implied warranty of merchantability or fitness, which extend beyond the description of the face there of. If the product does not perform as warranted herein, purchaser's sole remedy shall be repair or replacement, at the option of Ludlum Measurements. In no event will Ludlum Measurements be liable for damages, lost revenue, lost wages, or any other incidental or consequential damages, arising from the purchase, use, or inability to use product.

RETURN OF GOODS TO MANUFACTURER

If equipment needs to be returned to Ludlum Measurements, Inc. for repair or calibration, please send to the address below. All shipments should include documentation containing return shipping address, customer name, telephone number, description of service requested, and all other necessary information. Your cooperation will expedite the return of your equipment.

**LUDLUM MEASUREMENTS, INC.
ATTN: REPAIR DEPARTMENT
501 OAK STREET
SWEETWATER, TX 79556**

**800-622-0828 325-235-5494
FAX 325-235-4672**

Table of Contents

<i>Introduction</i>	<i>1</i>
<i>Specifications</i>	<i>2</i>
<i>Safety Considerations</i>	<i>3</i>
Environmental Conditions for Normal Use	3-1
Cleaning Instructions	3-1
Electrical Safety Precautions	3-1
Warning Markings and Symbols	3-2
<i>Getting Started</i>	<i>4</i>
Unpacking and Repacking	4-1
Setting Up the Model 215	4-1
<i>Calibration Software</i>	<i>5</i>
Main Screen Tab	5-2
Current Operating Mode	5-3
Current Status	5-3
Current Status Parameters	5-4
Calibration Data/Charging Stand Tab	5-4
Calibration Data	5-5
Charging Stand	5-5
Calibration Data Parameters	5-5
Charging Stand Parameters	5-6
Plateau/Efficiency Tab	5-6
Plateau	5-7
Efficiency	5-8
Debugger Program	5-8
<i>Recycling</i>	<i>6</i>
<i>Parts List</i>	<i>7</i>
Model 215 Main Board, Drawing 110 X 099	7-1
Model 215-20 LED/Audio Board, Drawing 110 X 176	7-5
Model 215-20 Charger Board, Drawing 110 X 142	7-6
Model 215-20 Communications Controller Board, Drawing 110 X 173	7-7
Model 215-20 Spare Parts	7-8
<i>Drawings</i>	<i>8</i>

Section**1****Introduction**

The Ludlum Model 215 Alpha Frisker is an air proportional detector designed to be used in detecting low-activity alpha radiation. The detector requires a charging/calibration stand (Ludlum Model 215-20), a 15-volt wall transformer, and an RS-232 communications cable for calibration. The Model 215 operating voltage is altitude sensitive. The detector can be used as a hand monitor while placed in position on the charging/calibration stand. A blinking red LED and clicking audio sound indicate activity, and a steady-tone alarm audio warns of contamination. The detector can also be removed from the stand and used as a frisker for at least 10 minutes, typically 15 minutes, before recharging is necessary. The maximum recharge time is 30 minutes to full charge. The Model 215 consists of a conductive plastic body with internal electronics. The window consists of 0.4 mg/cm² metallized polyester with an aluminum screen (79% open). The window can be easily replaced by removing four screws to open the back of the probe.

*Model 215**Model 215-20
Charging/Calibration Stand**Model 215 in the
Charging/Calibration Stand*

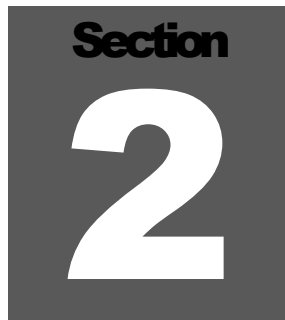
A dark gray square containing the word "Section" in a bold, sans-serif font at the top, and a large, white, stylized number "2" in the center.

Specifications

Indicated Use: alpha frisking, hand monitor with alarm

Detector Type: alpha air proportional probe with integrated electronics

Operation: While sitting on the calibration/charging stand, the probe may be used as a hand monitor. A blinking red LED and click audio indicate activity, and a steady-tone alarm audio warns of contamination. The probe may also be removed from the stand and used as a frisker for at least 10 minutes, typically 15 minutes before recharge. Maximum recharge time is 30 minutes to full charge, while the maximum time to operation from a fully discharged state is 5 minutes.

Display: Red LED – blinking (alpha pulse) or continuous (alarm)

Amber LED – trouble

Green LED – ok

Window: 0.4 mg/cm² aluminized metalized polyester with aluminum screen (79% open). Can be easily replaced by removal of six screws on back of probe.

Window Area: Active – 139cm²

Open – 110cm²

Efficiency (4pi geometry): typically 10% for ²³⁹Pu

Audio: 85 dB at 30.5 cm (12 in.); programmable to other sound levels

Operating Voltage: altitude sensitive

Sea Level - 1950 volts

610 m (2000 ft) – 1900 volts

1524 m (5000 ft) – 1825 volts

2134 m (7000 ft) – 1775 volts

Counter Threshold Setting: -4 mV

Calibration Due Date: When exceeded, amber trouble light will illuminate (real time clock located in calibration/charging stand).

Construction: conductive plastic body with internal sealed electronics

Temperature Range: -20 to 50 °C (-4 to 122 °F);
may be certified to operate at -40 to 65 °C (-40 to 150 °F)

Probe Size: 24.1 x 11.4 x 3.8 cm (9.5 x 4.5 x 1.5 in.) (H x W x D)
In stand: 26.7 x 14.7 x 7.6 cm (10.5 x 5.8 x 3.0 in.) (H x W x D)

Weight: 0.54 kg (1.2 lb)

Power: The Model 215's internal capacitors provide power for at least 10 minutes, typically 15 minutes in a non-alarming condition. The capacitors will not be damaged by a complete discharge.

Accessories:

Model 215-20Charging/Calibration Stand: Input power is +15 V (+12 V minimum to +20 V maximum) at 100 mA maximum. Four charging stands can be interconnected to run from a single 500 mA wall-mounted power supply. The stand interfaces with a personal computer or any other device with an RS-232 port and uses infrared communications to set parameters and run automatic plateau routines.

Stand Size: 13.5 x 14.7 x .58 cm (5.3 x 5.8 x 2.3 in.) (H x W x L)

Weight: 0.50 kg (1.1 lb)

Section
3**Safety Considerations**

Environmental Conditions for Normal Use

Indoor use only

Operating voltage is altitude sensitive

Temperature range of -20 to 50 °C (-4 to 122 °F)

Maximum relative humidity of less than 95% (non-condensing)

Pollution Degree 2 (as defined by IEC 664). (Normally only nonconductive pollution occurs. Temporary conductivity caused by condensation is to be expected.)

Cleaning Instructions

The Model 215 Alpha Frisker may be cleaned externally with a damp cloth, using only water as the wetting agent. Do not immerse the instrument in any liquid.

Electrical Safety Precautions**Caution!**

Verify instrument voltage input rating before connecting to a power converter. If the wrong power converter is used, the instrument and/or power converter could be damaged.

When Installing the Unit:

- Do not expose the unit to rain or an environment where it may be splashed by water or other liquids, as doing so may result in fire or electric shock.

- Use the unit only with the voltage specified on the unit. Using a voltage higher than that which is specified, may result in fire or electric shock.
- Do not cut, kink, otherwise damage nor modify the power supply cord. In addition, avoid using the power cord in close proximity to heaters, and never place heavy objects – including the unit itself – on the power cord, as doing so may result in fire or electric shock.
- Avoid installing or mounting the unit or its power supply in unstable locations, such as on a rickety table or a slanted surface. Doing so may result in the unit falling down and causing personal injury and/or property damage.

Warning Markings and Symbols

Caution!

The operator or responsible body is cautioned that the protection provided by the equipment may be impaired if the equipment is used in a manner not specified by Ludlum Measurements, Inc.

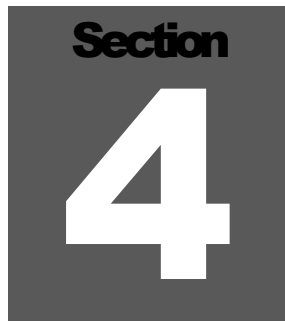

The “CE” mark is used to identify this instrument as being acceptable for use within the European Union.

A dark gray square containing the word "Section" in a bold, white, sans-serif font at the top. Below it is a large, white, bold number "4".

Getting Started

Unpacking and Repacking

Remove the calibration certificate and place it in a secure location. Remove the instrument and stand, and ensure that all of the items listed on the packing list are in the carton. Check individual item serial numbers and ensure calibration certificates match. The Model 215 Alpha Frisker serial number is located on the label on the base or the body of the detector for model and serial number identification.

To return an instrument for repair or calibration, provide sufficient packing material to prevent damage during shipment. Also, provide appropriate warning labels to ensure careful handling.

Every returned instrument must be accompanied by an **Instrument Return Form**, which can be downloaded from the Ludlum website at www.ludlums.com. Find the form by clicking the “Support” tab and selecting “Service Department” from the drop-down menu. Then choose the appropriate Service Department division where you will find a link to the form.

Setting Up the Model 215

After unpacking the Model 215, the calibration/charging stand (Model 215-20), and the 15-volt wall transformer, the detector will need to be charged. The maximum charge time is 30 minutes to full charge. Plug the 15-volt wall transformer into the charging stand and place the Model 215 on the stand.

The ON/OFF switch must be in the ON position in order for the Model 215 to be charged.

Note: The ON/OFF switch is not an instrument on/off switch. It is a charging on/off switch. The switch either connects or disconnects the ultracaps, which means the switch must be ON to either charge the ultracaps or in order to pull the instrument out of the stand and have it operate on its own. When the switch is in the OFF position, it can still turn ON when in the stand only.

The Green LED should light up and stay on. If any other LED is lit, there is a problem with the detector, or a parameter may not be set correctly. The Green LED will blink in low power conditions and when charging.

Expose the Model 215 to a low-activity alpha source. Ensure that the source is detected and that the alarm is set off once the counts exceed the alarm points.

To change factory settings, the detector will need to be placed in the calibration/charging stand. The stand will need to be connected to a computer via the RS-232 communications cable. New parameters can then be set up using the software provided with the Model 215. The Model 215 software section in this manual should be used as a reference for parameter changes. Once the parameters are established and stored in the instruments internal EEPROM, the Model 215 is ready for use.

In the likely event that an error occurs when restoring data from the Model 215's internal EEPROM on power-up, the Model 215 will generate a visual and audible alarm. The audible alarm will be a single tone once per second while all LEDs on the Model 215 will be lit. In this case, place the Model 215 in the calibration/charging stand and issue the "uP Load Default Setup" command from the Model 215 software. As a result, a new device that has never been initialized should always report a system setup error. In either case, the Model 215 will require calibration once default settings have been restored.

Section
5**Calibration Software**

The Model 215 Calibration Software package (part # 4110-217) allows the user to calibrate a Model 215 instrument and provides user-friendly access to the Model 215 features, including a general status check, as well as the ability to view and change calibration parameters, run a plateau, and calculate the efficiency of a Model 215 instrument.

The software interfaces with the instrument using an RS-232 serial connection. Instrument status parameters are updated every two seconds, allowing for continuous monitoring of an instrument, as well as the connection between the instrument and the charging stand. The auto-update feature can be started and stopped at the discretion of the user. The software also contains the Model 215 Debugger program, which can be accessed through the Debug menu on the main screen.

The software contains three tabs: the Main Screen tab, the Calibration Data/Charging Stand tab, and the Plateau/Efficiency tab.

Main Screen Tab

The following image shows an example of the main screen after a successful serial connection with the charging stand, as well as a successful connection with a Model 215 instrument.

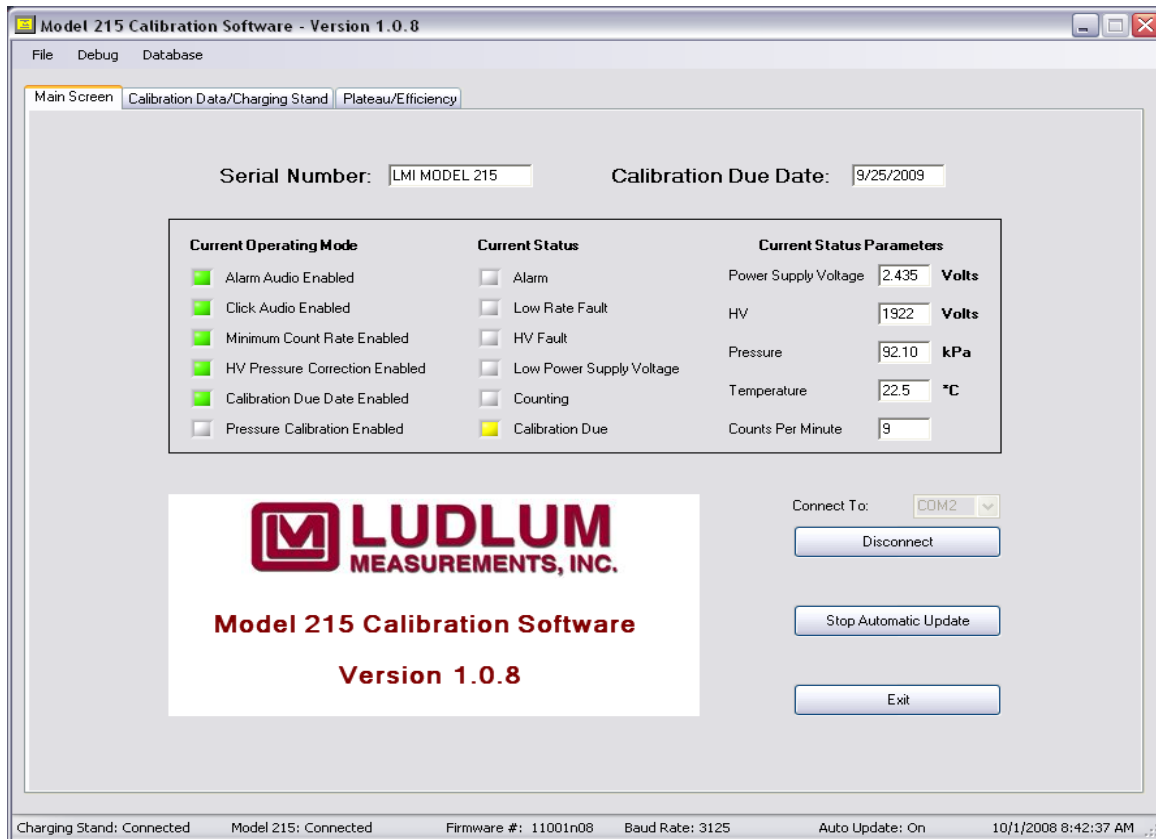

To establish a serial connection to the instrument, simply click on the Connect button. Once a successful connection is established, the status bar on the lower left-hand corner of the screen will show both the charging stand and Model 215 are connected. The status bar also displays the firmware number of the instrument, the baud rate of the serial connection, whether or not auto-updating is on or off, and the current system date/time.

At the top of the main screen, the serial number of the instrument and calibration due date are displayed. The charging/calibration stand contains a real-time clock, which is used to update the time in the Model 215 every minute. The 215 checks this time to determine whether or not the calibration due date has passed. If the calibration due date has passed (as in this example), the “Calibration Due” indicator will turn yellow.

Below the serial number and calibration due date is another panel, which is divided into three sections: Current Operating Mode, Current Status, and Current Status Parameters.

Current Operating Mode

The Current Operating Mode section of the middle panel contains indicators that allow the user to toggle on or off for the following parameters:

- **Alarm Audio**
- **Click Audio**
- **Minimum Count Rate**
- **HV Pressure Correction**
- **Calibration Due Date On/Off**
- **Pressure Calibration Enabled**

Simply click on a gray button located to the left of the preferred feature to turn that feature on or click on a green button to turn the associated feature off. A command will be sent to the instrument, and after a short delay, the requested change is made.

Current Status

The Current Status section of the middle panel contains indicators that inform the user of any of the following situations:

- **Instrument Alarm** – Indicator will turn red.
- **Low Rate Fault** – Indicator will turn yellow.
- **HV Fault** – Indicator will turn yellow.
- **Low Power Supply Voltage** – Indicator will turn yellow when the power supply voltage is low. This means that the instrument needs to be charged.
- **Counting** – Indicator will turn green when the instrument is counting.
- **Calibration Due** – Indicator will turn yellow when the calibration due date has passed, and the instrument needs to be recalibrated.

Current Status Parameters

The Current Status Parameters section provides the user with a current reading for each of the following instrument parameters:

- **Power Supply Voltage** (volts)
- **High Voltage** (volts)
- **Pressure** (kPa)
- **Temperature** (Celsius)
- **Counts Per Minute**

Calibration Data/Charging Stand Tab

The following image shows an example of the Calibration Data/Charging Stand tab that has been populated with data.

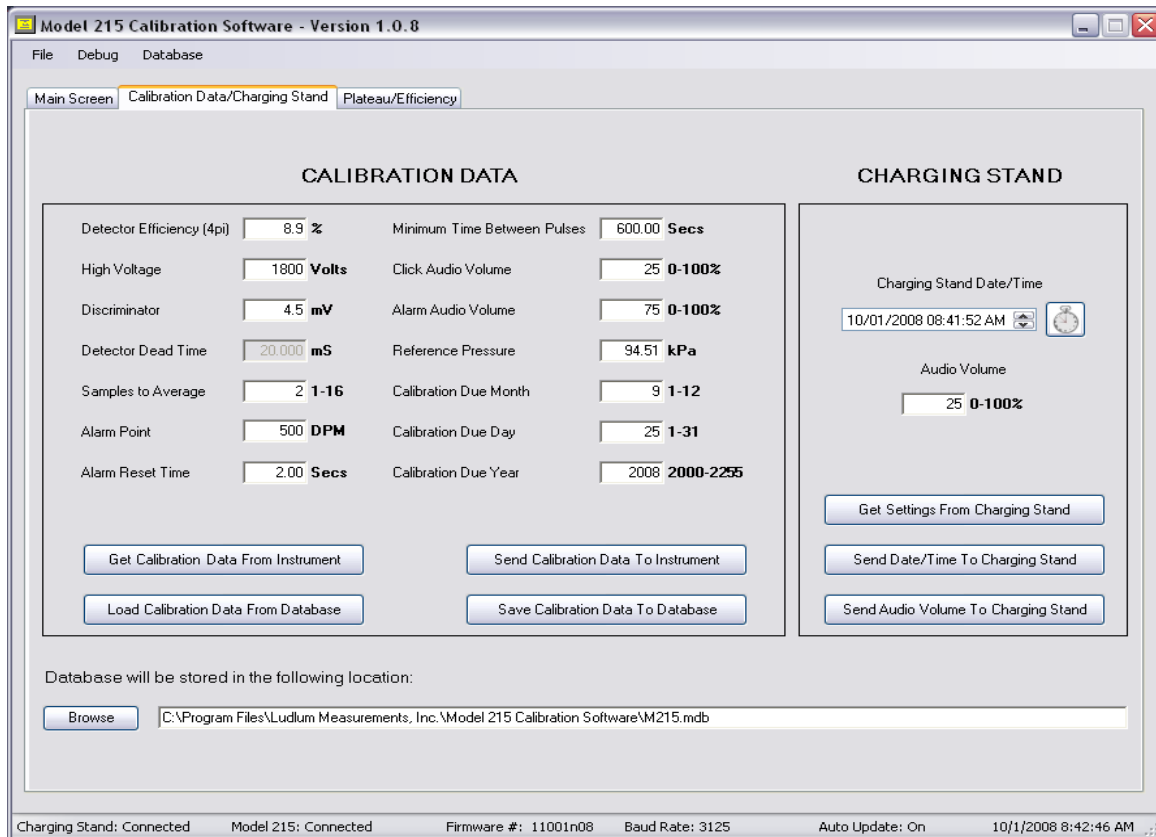

Calibration Data

Calibration data is saved in two locations: the instrument itself and in a Microsoft Access database, which is located in the program installation folder. The default installation folder is C:/Program Files/Ludlum Measurements, Inc/M215 Calibration Software.

There are four buttons in the Calibration Data section. The top two buttons allow the user to get/send calibration data from/to the instrument itself. The bottom two buttons allow the user to load/save calibration data from/to the database. The database allows the user to roll back to the previously saved calibration settings if necessary. If the database is located in a folder other than the one specified in the bottom text box, click the Browse button to choose the correct folder.

Charging Stand

There are four buttons in the Charging Stand section. The first button allows the user to get the charging stand settings from the charging stand. The second button sends the current date and time displayed in the Charging Stand Date/Time field to set the real-time clock (RTC) in the charging stand. The third button allows the user to set the audio volume for the charging stand. The fourth button is a small clock icon, which may be clicked to automatically load the Charging Stand Date/Time field with the current date and time as displayed in the lower right corner of the software.

Below is a list of the parameters that may be viewed and/or changed under the Calibration Data/Charging Stand tab (units for each parameter are in parentheses):

NOTE: Value ranges are what the software will accept without error.

Calibration Data Parameters:

- **Detector Efficiency** (% steps, 0.1-100%)
- **High Voltage** (volts, 0-2500)
- **Discriminator** (mV steps, 0.3-11.5 mV)
- **Detector Dead Time** (mSec, 20.0 mSec)
- **Samples To Average** (1-16)
- **Alarm Point** (DPM, 0-10,000 DPM)
- **Alarm Reset Time** (secs, 1-65.5 secs)
- **Minimum Time Between Pulses** (secs, 1-655 secs)
- **Click Audio Volume** (0-100%)
- **Alarm Audio Volume** (0-100%)

- **Reference Pressure** (kPa, 30-150 kPa)
- **Calibration Due Month** (1-12)
- **Calibration Due Day** (1-31)
- **Calibration Due Year** (2000-2255)

Charging Stand Parameters:

- **Charging Stand Real Time Clock (RTC)** (any valid date and time)
- **Audio Volume** (0-100%)

Plateau/Efficiency Tab

The following image shows an example of the Plateau/Efficiency tab.

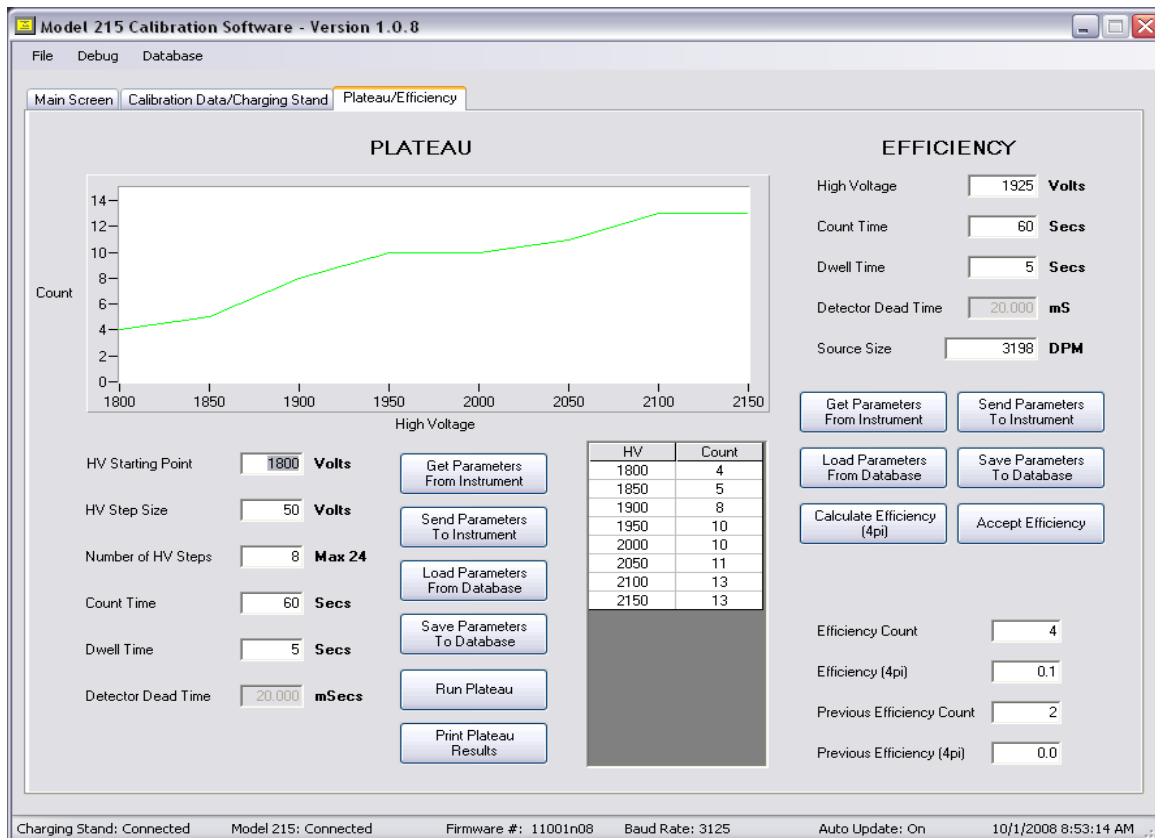

The Plateau/Efficiency tab is divided into two sections, plateau and efficiency. Each section has a unique set of parameters.

Plateau

The Plateau section contains the following parameters (units and value ranges for each parameter are in parentheses):

NOTE: Value ranges are what the software will accept without error.

- **HV Starting Point** (Volts, 1300-1900 V)
- **HV Step Size** (Volts, 1-100 V)
- **Number of HV Steps** (1-24)
- **Count Time** (secs, 1-655)
- **Dwell Time** (secs, 1-65,535)
- **Detector Dead Time** (mSec, 20.0 mSec)

The Plateau section contains the same four buttons as the Calibration tab, allowing the user to read parameters from and save parameters to both the parameter backup database and the instrument itself. To run a plateau, click the Run Plateau button, located at the bottom of the plateau button column. Note that the button caption now reads “Stop Plateau.” This button allows the user to stop the plateau before it completes. After the Run Plateau button is pressed, the plateau parameter text boxes are automatically loaded with the current instrument data. When a plateau starts, a text box appears at the bottom of the screen to alert the user as to the length of time remaining for completion of the current step.

After each step in the plateau, the instrument sends over the plateau results, which are then stored in a grid located to the right of the plateau parameter buttons. A graph of the results is also generated and displayed above the plateau parameters. When the plateau is complete, the final grid and graph will be displayed, the caption of the Stop Plateau button will change to Run Plateau, and another button will appear, giving the user the option to print the plateau results. Plateau results from a stopped plateau can also be printed when the plateau stops.

If a plateau step is missed by either the software or the instrument, the plateau will automatically be stopped, and one last step will be displayed on the grid. In this case, the last step in the grid will have a red background to let the user know that there was a problem with the plateau.

Efficiency

The Efficiency section contains the following parameters (units for each parameter are in parentheses):

- **High Voltage** (volts, 0-2500 V)
- **Count Time** (secs, 1-65,535 secs)
- **Dwell Time** (secs, 1-65,535 secs)
- **Detector Dead Time** (mS, 20.0 mS)
- **Source Size** (DPM, 1-4,294,967,295 DPM)

The Efficiency section contains the same four buttons as the Calibration and Plateau tabs, allowing the user to read parameters from and save parameters to both the parameter backup database and the instrument. To calculate efficiency, click on the Calculate Efficiency button. When an efficiency calculation has started, the caption of the Calculate Efficiency button will now read “Stop Efficiency.” This allows the user to stop an efficiency count at any time. The current efficiency parameters from the instrument will load into the appropriate text boxes, and efficiency counting will begin.

Five new text boxes will appear. The first text box shows the efficiency count time remaining. When efficiency counting is over, the resulting efficiency count and calculated value is displayed in the second and third text boxes, respectively. The fourth and fifth text boxes display the efficiency count and efficiency from the last efficiency calculation. A sixth button also appears, which allows the user to accept the newly calculated efficiency. Clicking the Accept Efficiency button will change the Detector Efficiency parameter under the Calibration Data tab. The new Calibration Data will then be sent to the Model 215 instrument.

Debugger Program

As mentioned earlier, the Model 215 Calibration Software also includes access to the Model 215 debugger. **NOTE:** This debugger is for advanced users only.

To load up the debugger program, click on the Debug menu at the top of the screen, then click on Launch Debugger. If there is a serial connection to the instrument, that serial connection is closed and auto-updating is disabled.

The image below shows an example of the Model 215 Debugger screen.

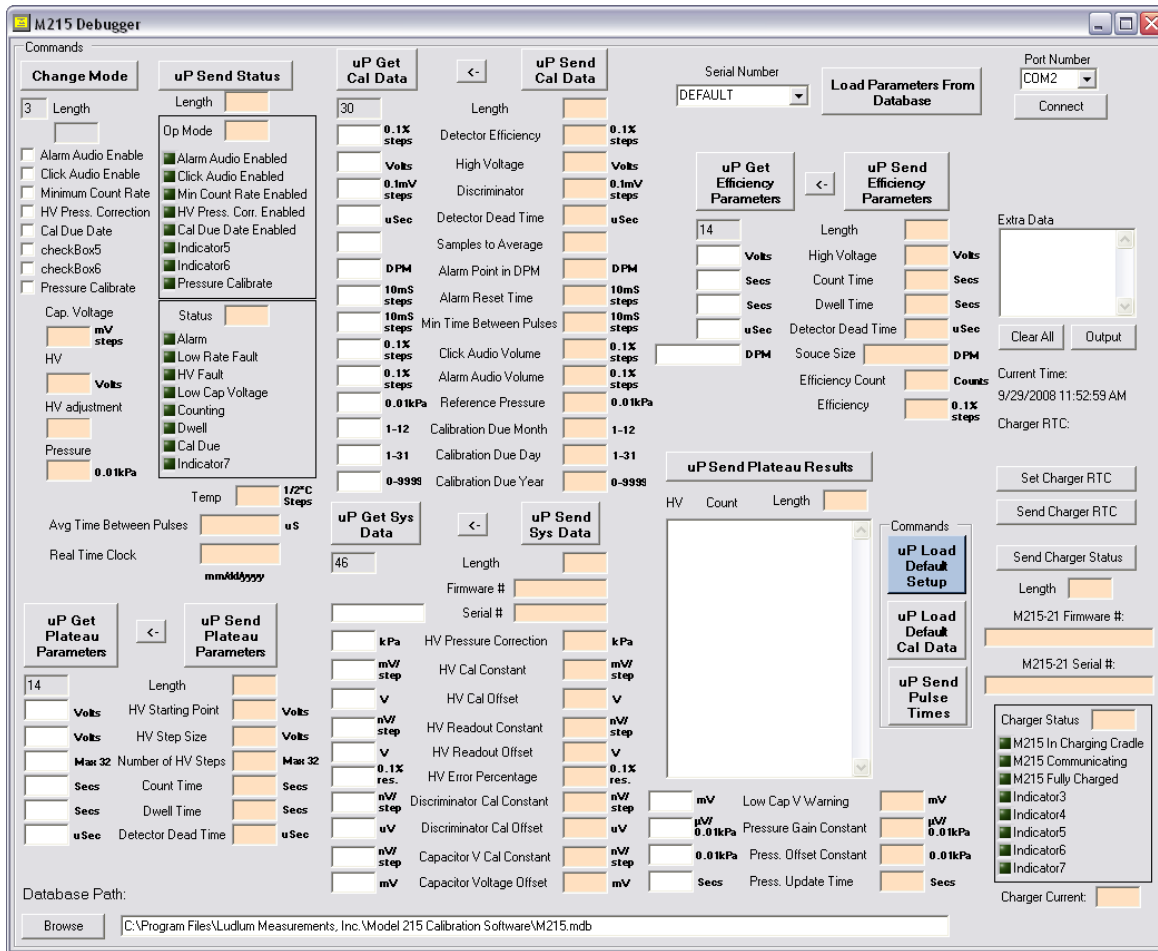

In the Model 215 Debugger program, the Get Data and the Send Data buttons are from the perspective of the Model 215 instrument. For example, to send new plateau parameters to the Model 215 instrument, the user would click on the “ μ P Get Plateau Parameters” button, and clicking on the “ μ P Send Plateau Parameters” button would load the current plateau parameters from the Model 215 instrument.

In addition to sending data to the Model 215 instrument, the Get Data buttons also saves a copy of the data to the Model 215 database, which is the same database used by the Model 215 calibration software.

NOTE: When you change any data in the Model 215 with the debugger software, the debugger software will automatically load the current system data from the Model 215 and will use the serial number it retrieves as the location to store the data in the database. If you plan to take advantage of the database feature, it is recommended that the first step performed when using the debugger software is to click the “ μ P Send Sys Data” and verify that the Model 215 has the appropriate serial number. If the serial number needs to be changed, make this change prior to performing any other debugger actions.

The Model 215 Database contains five data tables, one for each of the following parameter groups: Operating Mode, Plateau, Efficiency, Calibration, and Status parameters. As a result, each of the Get Data buttons ONLY save data to the appropriate data group in the database.

Parameters may be loaded from the database by selecting a serial number in the combo box at the top of the screen, then clicking on the Load Parameters From Database button. If there are parameters saved in the database for the selected serial number, the white text boxes for each of the five parameter groups will be loaded with those parameters. Otherwise, the white boxes will remain blank.

The location of the database used by the Model 215 debugger software is determined by the Database Path text box located at the bottom of the debugger software. To change the path where the database file resides, click on the Browse button and choose the folder that contains the Model 215 Database file.

To allow the user full control over the Model 215 Database, the Model 215 Database Software is also provided. A screen shot of the Model 215 Database Software is provided on the next page.

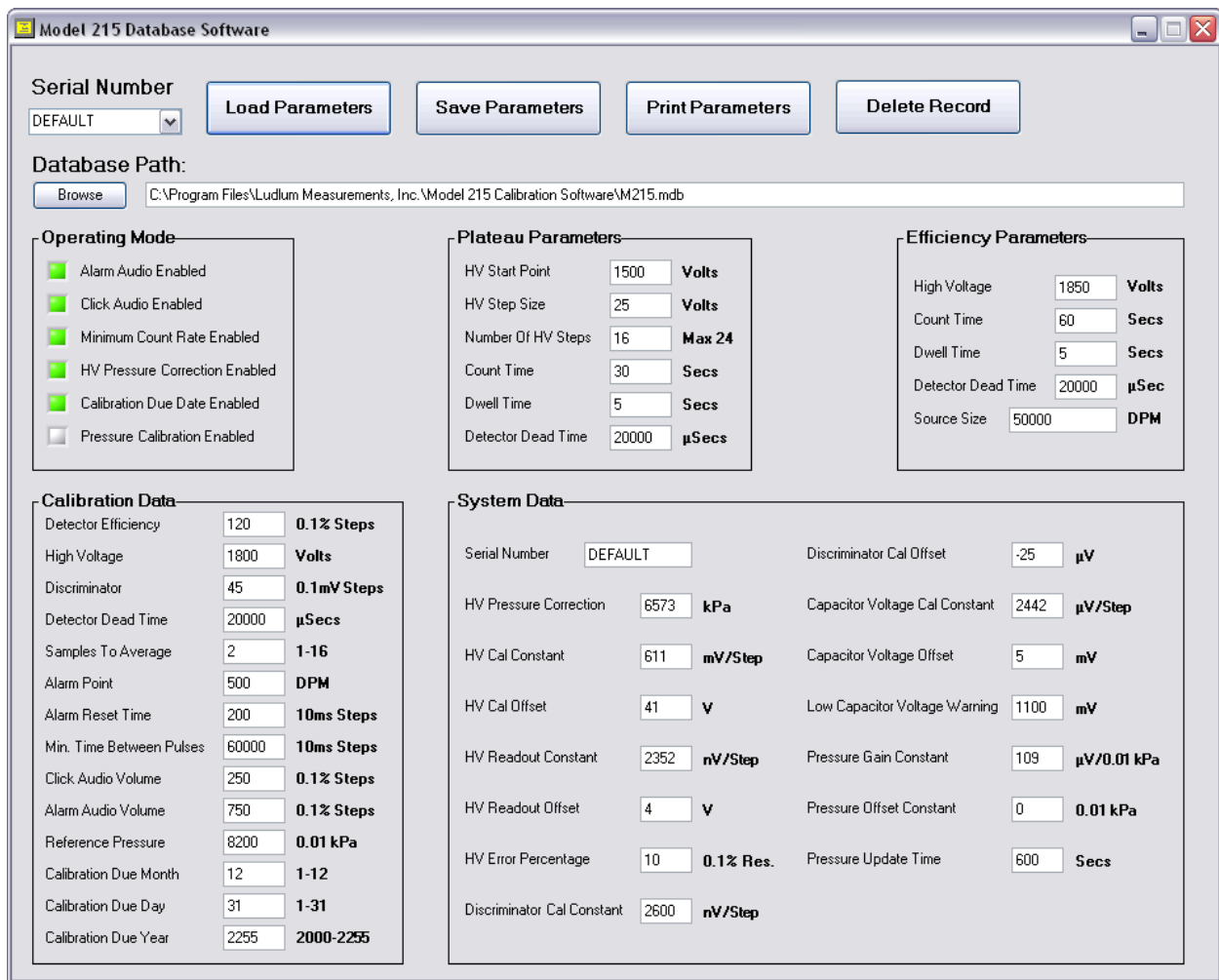

Section 6 Recycling

Ludlum Measurements, Inc. supports the recycling of the electronic products it produces for the purpose of protecting the environment and to comply with all regional, national and international agencies that promote economically and environmentally sustainable recycling systems. To this end, Ludlum Measurements, Inc. strives to supply the consumer of its goods with information regarding reuse and recycling of the many different types of materials used in its products. With many different agencies – public and private – involved in this pursuit, it becomes evident that a myriad of methods can be used in the process of recycling. Therefore, Ludlum Measurements, Inc. does not suggest one particular method over another, but simply desires to inform its consumers of the range of recyclable materials present in its products, so that the user will have flexibility in following all local and federal laws.

The following types of recyclable materials are present in Ludlum Measurements, Inc. electronic products, and should be recycled separately. The list is not all-inclusive, nor does it suggest that all materials are present in each piece of equipment:

Batteries	Glass	Aluminum and Stainless Steel
Circuit Boards	Plastics	Liquid Crystal Display (LCD)

Ludlum Measurements, Inc. products, which have been placed on the market after August 13, 2005 have been labeled with a symbol recognized internationally as the “crossed-out wheellie bin.” This notifies the consumer that the product is not to be mixed with unsorted municipal waste when discarding. Each material must be separated. The symbol will be placed near the AC receptacle, except for portable equipment where it will be placed on the battery lid.

The symbol appears as such:



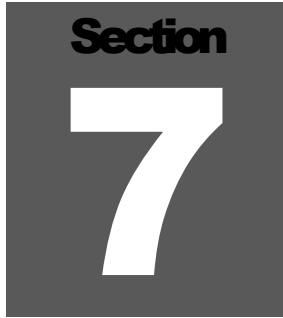

Parts List

	Reference	Description	Part Number
Model 215 Alpha Frisker	UNIT	Completely Assembled Model 215 Alpha Frisker	48-3695
		Completely Assembled Model 215-20 Charging/Calibration Stand	48-3567
		Model 215 Detector Only	4110-109
		Model 215 Calibration Kit	4110-217
Model 215 (Main Board), Drawing 110 X 211	BOARD	Completely Assembled Circuit Board	5110-211
CAPACITORS	C1	.01 μ F, 500V	04-5696
	C2	.0039 μ F, 3KV	04-5498
	C3	100pF, 3KV	04-5532
	C4-C6	.01 μ F, 500V	04-5696
	C7	.0039 μ F, 3KV	04-5498
	C8-C9	.01 μ F, 500V	04-5696
	C10	1 μ F, 35V	04-5656
	C11-C12	.01 μ F, 500V	04-5696
	C13	.0039 μ F, 3KV	04-5498
	C14	10PF, 100V	04-5673
	C15-C16	.01 μ F, 500V	04-5696
	C17	.01 μ F, 50V	04-5664
	C18	1 μ F, 35V	04-5656
	C19-C21	.01 μ F, 500V	04-5696
	C22	.001 μ F, 100V	04-5659
	C23	.01 μ F, 500V	04-5696
	C24	.1 μ F, 50V	04-5663
	C25	.01 μ F, 500V	04-5696
	C26	68 μ F, 10V	04-5654
	C27-C28	.01 μ F, 500V	04-5696

	Reference	Description	Part Number
	C29	68 μ F, 10V	04-5654
	C30-C35	.01 μ F, 500V	04-5696
	C36	0.1 μ F 100V	04-5792
	C37	.01 μ F, 500V	04-5696
	C38-C41	0.1 μ F, 100V	04-5792
	C42	3 μ F, 10V	04-5499
	C43	15PF, 100V	04-5721
	C44	3 μ F, 10V	04-5499
	C45	10 μ F, 10V	04-5757
	C46	15 PF, 100V	04-5721
	C47	1 μ F, 35V	04-5656
	C48	.047 μ F, 50V	04-5662
	C49	10PF, 100V	04-5673
	C50	10 μ F, 10V	04-5757
	C52	0.1 μ F, 100V	04-5792
	C53	4.7 μ F, 50V	04-5796
	C54-C55	0.1 μ F, 100V	04-5792
	C56	4.7 μ F, 50V	04-5796
	C57	0.1 μ F, 100V	04-5792
	C58	1 μ F, 35V	04-5656
	C59	.22 μ F, 50V-C	04-5694
	C60	4.7 μ F, 50V	04-5796
	C61	0.1 μ F, 100V	04-5792
	C62	10pF, 100V	04-5673
	C63	4.7 μ F, 50V	04-5796
	C64	0.1 μ F, 100V	04-5792
	C65	330pF, 100V	04-5657
	C66	4.7 μ F, 50V	04-5796
	C67	.0015 μ F, 100V	04-5680
	C72	.001 μ F, 2KV	04-5698
	C73	0.1 μ F, 100V	04-5792
	C74	1 μ F, 50V	04-5953
TRANSISTORS	Q1	SST201	05-5929
	Q2	CMXT3904	05-5888
	Q3	Si2301BDS-TI	07-6486
	Q4	MMBT3904LT1	05-5841

	Reference	Description	Part	Number	
DIODES	CR1-CR10	CMPD2005S	07-6468		
	CR11	CMSH1-40M	07-6411		
	CR12-CR15	CMPD2005S	07-6468		
	CR16	MMSZ5261BT1G	07-6518		
	CR17	CMSH1-40M	07-6411		
	CR18	MMBD014LT1	07-6353		
	CR19	CMSH1-100M	07-6516		
	CR20	CMP SH-3CE-LF	07-6528		
	CR21	MBR0520LT1G	07-6422		
	D1	CMP SH-3	07-6489		
	D3-D7	CMSH1-100M	07-6516		
	LED	DS1	HSMJ-A401-U40M1	07-6520	
		DS2	HSMM-A400-U4QM2	07-6522	
DS3-DS4		HSMA-A401-U45M1	07-6521		
DS5		HSMM-A400-U4QM2	07-6522		
DS6		HSMJ-A401-U40M1	07-6520		
SWITCH		SW1	48BFSP1M6QT	08-6839	
	VR1	TPS61041	05-5902		
CRYSTAL	Y1	XTAL-4 MHZ	01-5264		
INTEGRATED CIRCUITS	U1	HSDL-3201-021	07-6464		
	U2	MCP2122-E/SNG	06-6692		
	U3	LMH6645MH	06-6554		
	U4	LMC7111BIM5X	06-6410		
	U5	MAX985EUK-T	06-6459		
	U6	MAX5842LEUB	06-6705		
	U7	LT1304CS8	06-6394		
	U8	MAX809REUR-LF	06-6690		
	U9	INA126UA	06-6726		
	U10	PIC18LF2520-I/SO	06-6696		
	U11	SM5420-030-A-P-S	2311127		
	U12	MAX4544EUT-T	06-6639		
	U13	MCP9800AOT-M/OTG	06-6687		
	U14	SN74AHC1G14	06-6556		
	U16	LT1790BIS6-2.5	06-6691		

	Reference	Description	Part Number
	U17	MAX629ESA	06-6707
	U18	LT1976EFE	06-6688
	U19	MIC1557BM5	06-6457
RESISTORS	R1	100K, 1/4W, 1%	12-7834
	R2	10M, 1/4W, 1%	12-7996
	R3	1M, 1/4W, 1%	12-7844
	R4	1K, 1/4W, 1%	12-7832
	R5	10M, 1/4W, 1%	12-7996
	R6	15K, 1/4W, 1%	12-7998
	R7	10M, 1/4W, 1%	12-7996
	R8	2K, 1/4W, 1%	12-7926
	R9	5G, 10%	12-7228
	R10	150K, 1/4W, 1%	12-7833
	R11	100K, 1/4W, 1%	12-7834
	R12	5.1M, 1/8W, 2%	12-7979
	R13	100K, 1/4W, 1%	12-7834
	R14	124K, 1/8W, 1%	12-7032
	R15	1M, 1/4W, 1%	12-7844
	R16	10 OHM, 1/8W, 1%	12-7836
	R17	1M, 1/4W, 1%	12-7844
	R18	953K, 1/8W, 1%	12-7950
	R19	332 OHM, 1/4W, 1%	12-7854
	R20	150K, 1/4W, 1%	12-7833
	R21	124K, 1/4W, 1%	12-7032
	R22	100K, 1/4W, 1%	12-7834
	R23	221K, 1/4W, 1%	12-7845
	R24-R25	10K, 1/4W, 1%	12-7839
	R26	1K, 1/4W, 1%	12-7832
	R27	100 OHM, 1/4W, 1%	12-7840
	R28	1K, 1/4W, 1%	12-7832
	R29	1.96K, 1/4W, 1%	12-7065
	R30	10K, 1/4W, 1%	12-7839
	R31	1K, 1/4W, 1%	12-7832
	R32	10K, 1/4W, 1%	12-7839
	R33	1K, 1/4W, 1%	12-7832
	R34	10K, 1/4W, 1%	12-7839
	R35	1M, 1/4W, 1%	12-7844
	R36	221K, 1/4W, 1%	12-7845
	R37	309K, 1/4W, 1%	12-7231
	R38	1M, 1/4W, 1%	12-7844
	R39	237K, 1/8W, 1%	12-7237

	Reference	Description	Part Number
	R40	105K, 1/4W, 1%	12-8069
	R41	100K, 1/4W, 1%	12-7834
	R42	475K, 1/4W, 1%	12-7859
	R43	26.7K, 1/8W, 1%	12-7884
	R44	56.2K, 1/4W, 1%	12-7873
	R45	100K, 1/4W, 1%	12-7834
	R46-R51	243 OHM, 1/4W, 1%	12-7905
	R52	10K, 1/4W, 1%	12-7839
	R53	237K, 1/8W, 1%	12-7237
	R54	0 OHM jumper	12-7193
	R55	33 ohm, 1/4W, 1%	12-8272
	R58	0 OHM jumper	12-7193
	R59	33 ohm, 1/4W, 1%	12-8272
	R60	150K, 1/4W, 1%	12-7833
CONNECTORS	P1	1128-52-0319 WHITE	18-9251
	P2	1128-52-0310 BLK	18-9252
	P3	532530470	13-9538
	P4	640457-2 MTA100	13-8147
	P5	640457-3 MTA100	13-8165
INDUCTORS	L1	10 μ H	21-9968
	L2	DS1608C-333	21-9096
	L3	CTDS3316PF-473M	21-9066
TRANSFORMER	T1	XFMR-30132R	21-9925
Model 215-20 LED/Audio Board Drawing 110 X 176	BOARD	Completely Assembled LED/Audio Board	5110-175
CAPACITORS	C1	47 μ F, 20V	04-5714
	C2	10 μ F, 10V	04-5757
	C3	47 μ F, 20V	04-5714
	C5	1.5F, 5.5V	04-6092
	C6	10 μ F, 10V	04-5757
	C12	10pF, 100V	04-5673

	Reference	Description	Part Number
INTEGRATED CIRCUIT	U1	LM358DG	06-6312
	U2	MSP430F2012RSA	06-6729
	U3	24FC1025	06-6717
	U6	PCF8593TD	06-6403
RESISTOR	R1	221K, 1/4W, 1%	12-7845
	R2	100K, 1/4W, 1%	12-7834
	R3-R7	4.75K, 1/4W, 1%	12-7858
	R9-R11	22.1 Ohm, 1/4W, 1%	12-7055
	R12	33.2 Ohm, 1/8W, 1%	12-7837
	R15	100 Ohm, 1/4W, 1%	12-7840
	R16	2.21K, 1/4W, 1%	12-7835
	R19	47.5K, 1/4W, 1%	12-7872
CRYSTALS	Y1, Y2	MS2V-T1S	01-5740
TRANSISTORS	Q1	RK7002A	05-5931
	Q2-Q5	CMXT3904	05-5888
	Q6	SI2302ADS-T1	07-6487
DIODES	CR1	SD103-AW	07-6420
MISC	DS1	Red LED	07-6520
	DS2	Amber LED	07-6521
	DS3	Green LED	07-6522
	DS4	Blue LED	07-6538
	J1	CON7	13-8633
	J2	640456-2MTA	13-8073
	J3	SLM-104-01-S-S	13-8986
	L1	56mH	21-9040
Model 215-20 Charger Board, Drawing 110 X 142	BOARD	Completely Assembled Charger Board	5110-142
CAPACITORS	C1	0.1 μ F, 100V	04-5792
	C2	470pF, 2KV	04-5720

	Reference	Description	Part Number
	C3	68 μ F, 16V-T	04-5768
	C4	10 μ F-T, 25V	04-5655
	C5-C6	100 PF, 3 KV	04-5735
	C7	68 μ F, 16V-T	04-5768
TRANSISTOR	Q1-Q2	Si4850EY	06-6714
INTEGRATED CIRCUITS	U1	LM2937ES-12	05-5932
	U2	MAX4372TEUK-T	06-6669
	U4	MIC1557BM5	06-6457
	U5	CD4093BQ	06-6716
	U8-U9	TPS2828DBVR	06-6715
RESISTORS	R1	0.25 OHM, 1W, 1%	12-7203
	R5	90.9K, 1/4W, 1%	12-7224
	R6-R7	14.7 K, 1/4 W, 1%	12-7068
CONNECTORS	P1	640457-4 MTA100X4RA	13-8089
	P2-P4	PAD	18-9160
Model 215-20 Communications Controller Board Drawing 110 X 173	BOARD	Completely Assembled Communications Controller Board	5110-172
CAPACITORS	C1	10 μ F, 10V	04-5757
	C2	0.1 μ F, 100V	04-5792
	C3-C7	10 μ F, 10V	04-5757
	C8	1 μ F, 35V	04-5656
	C9	10 μ F, 10V	04-5757
	C10	10 μ F-T, 25V	04-5655
	C11	100 μ F, 16V-T	04-5794
	C12	1 μ F-T, 35V	04-5656
	C14, C15	15PF, 100V, 5%	04-5721
TRANSISTORS	Q2-Q5	CMXT3904	05-5888
INTEGRATED CIRCUITS	U2	MCP2122-E/SNG	06-6692
	U3	HSDL-3201-008	06-6693

	U4	SN74AHC1G14	06-6556
	U5	MAX3232EIDW	06-6702
	U7	MAX809REUR-LF	06-6690
	U8	PIC18LF2320-I/SO	06-6696
RESISTORS	R2-R4	22.1K, 1/4W, 1%	12-7843
	R5, R6	1K, 1/4W, 1%	12-7832
	R8	100 Ohm, 1/4W, 1%	12-7840
	R12	221K, 1/4W, 1%	12-7845
	R15-R18	4.75K, 1/4W, 1%	12-7858
	R18-R21	22.1 Ohm, 1/8W, 1%	12-7055
	R22	33.2 Ohm, 1/8W, 1%	12-7837
CRYSTAL	Y2	4MHz Crystal	01-5264
MISC	D1	CMPSH-3 Diode	07-6489
	DS1	Amber LED	07-6521
	DS2	Red LED	07-6520
	DS3	Green LED	07-6522
	DS4	Blue LED	07-6538
	P1	53014-0610	13-8974
	P2	640456-4MTA 100	13-8088
	P3	07FE-BT-VK-N 7P	13-8633
	J1, J2	RAPC712	13-8445
	J3	640456-4MTA 100	13-8088

**Model 215-20
Spare Parts**

Qty.	Description	Part Number
1	Unimorph-PKM22EPPH4001-BO	21-9782
1	Model 215-21 Primary Pin Assy.	4275-169
1	Model 215-21 Charging Brd.	5110-142
1	Model 215-21 Charger Main Brd.	5110-172
1	Model 215-21 Charger Slave Brd.	5110-175
1	Model 215-21 Chg Pin Sleeve	7110-129
1	XFMR-WL MNT AC/DC 15V 24W; SWI24-15-N-P6	2313843

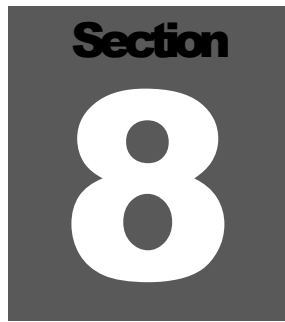

Section
8

Drawings

Model 215, Drawing 110 X 109

Model 215-20, Drawings 110 X 120

Model 215 Main Board, Drawing 110 X 211 (3 sheets)

Model 215 Main Board Layout, Drawing 110 X 215 (2 sheets)

Model 215-20 LED/Audio Board, Drawing 110 X 175

Model 215-20 LED/Audio Board Layout, Drawing 110 X 176A (2 Sheets)

Model 215-20 Charger Board, Drawing 110 X 142

Model 215-20 Charger Board Layout, Drawing 110 X 143 (2 Sheets)

Model 215-20 Communications Controller Board, Drawing 110 X 172

Model 215-20 Communications Controller Board Layout, Drawing 110 X 173 (2 sheets)

REVISION HISTORY			
REV	DESCRIPTION	DATE	BY
1	VALID	8/31/2007	DDW

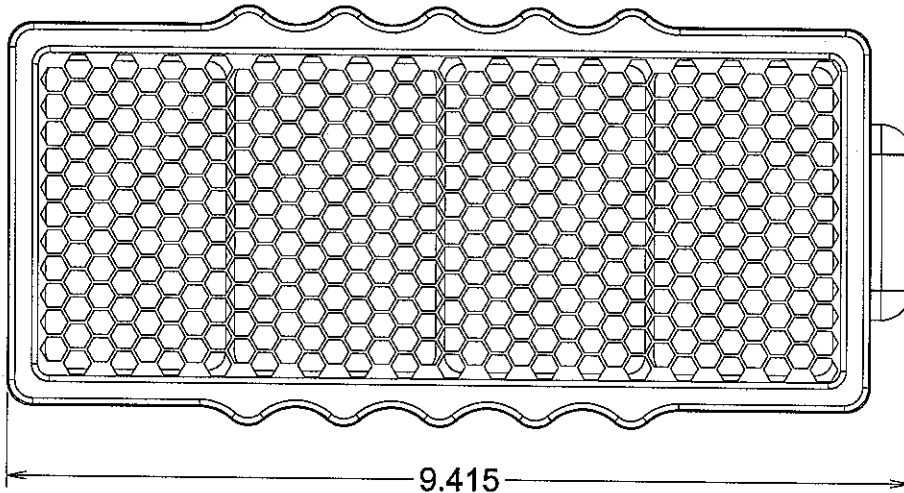
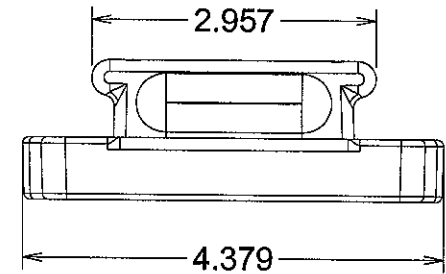
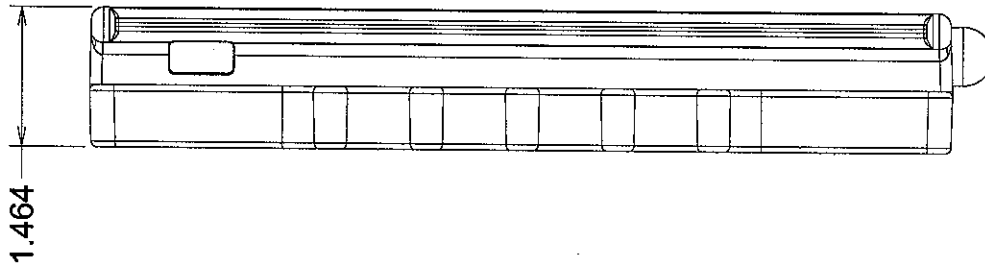
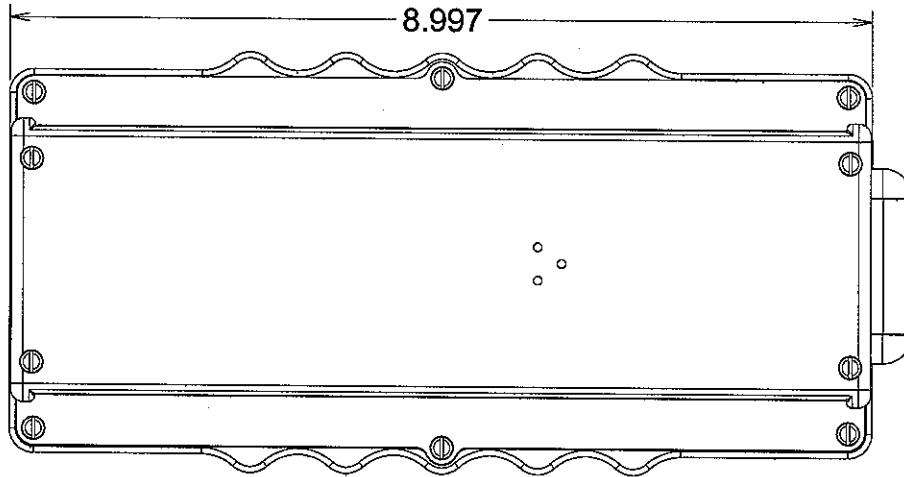

DWN	DATE	CHK	DATE	APP	DATE
DDW	8/31/07			<i>DDW</i>	<i>31 Aug 07</i>
DWG NUM: 4110-109					SCALE: <input type="checkbox"/> FULL <input type="checkbox"/> OTHER
TITLE M 215					
 LUDLUM MEASUREMENTS, INC. 501 OAK STREET SWEETWATER, TEXAS 79556		SERIES 110	SHEET 109		

VF

REVISION HISTORY			
REV	DESCRIPTION	DATE	BY
1	VALID	8/31/2007	DWatts
2	CHANGED MODEL #	9/17/2008	DWatts

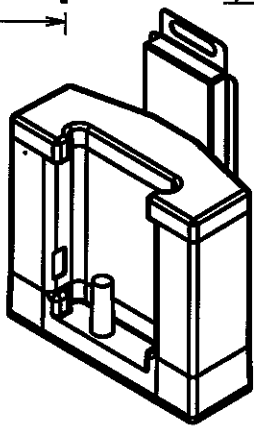
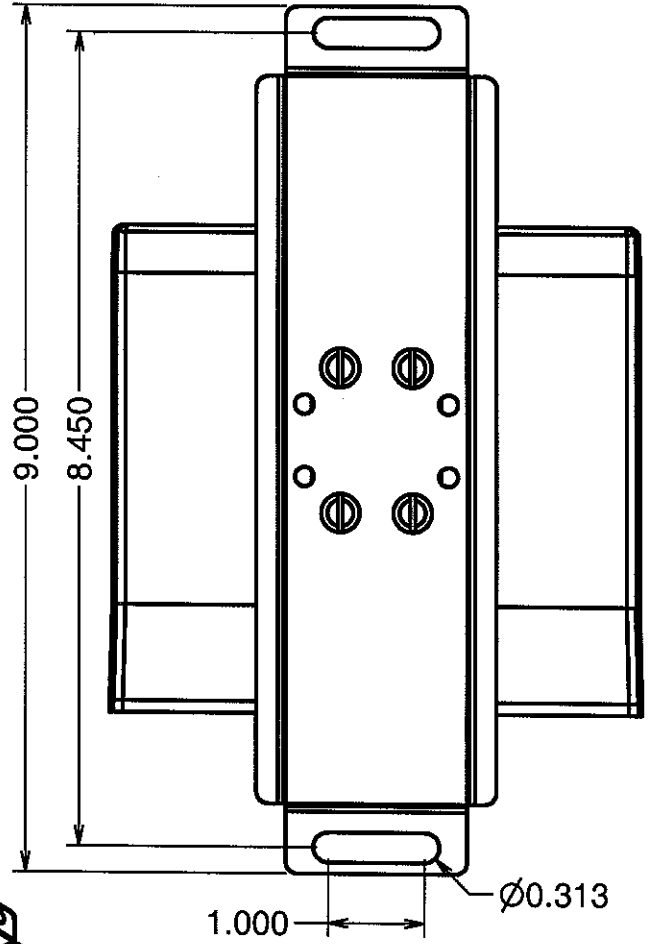
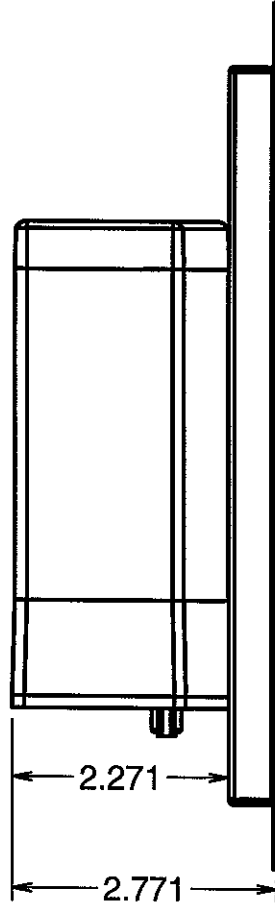
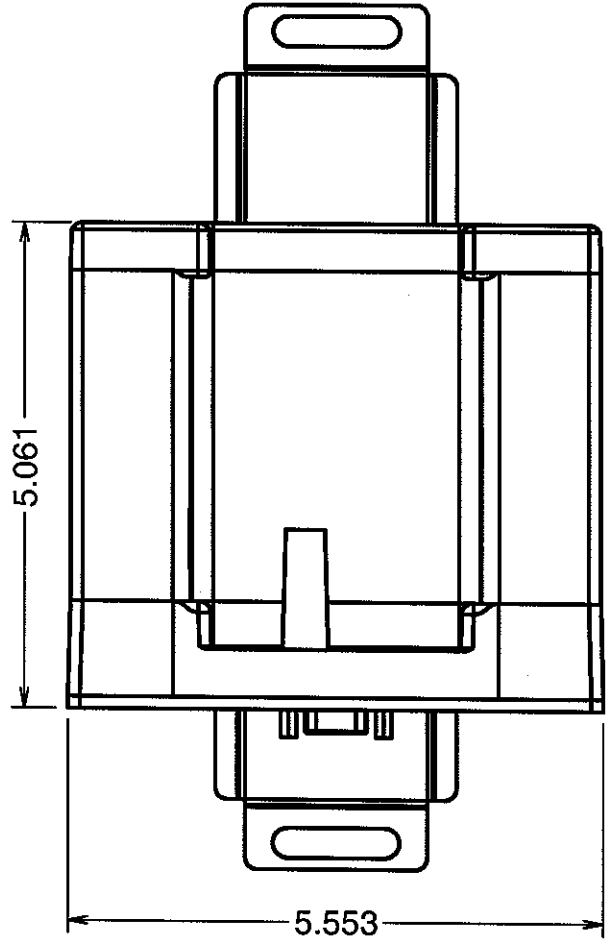

DWN	DATE	CHK	DATE	APP	DATE
DDWG	9/17/08			<i>[Signature]</i>	9/17-08
DWG NUM: 4110-120				SCALE: 1:1	
TITLE M 215-20 CAL STAND ASSEMBLY					
LUDLUM MEASUREMENTS, INC. 601 OAK STREET SWEETWATER, TEXAS 76556			SERIES	SHEET	
			110	120	

1

2

3

4

5

A

A

B

B

C

C

D

D

E

E

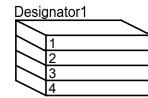
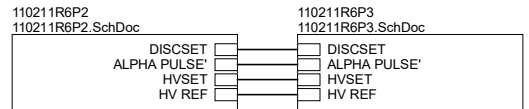

Top
Mid-Layer 1
Mid-Layer 2
Bottom

		PO Box 810 501 Oak Street Sweetwater, Texas 79556 U.S.A. 1-800-622-0828	
Drawn: PAB	7/18/2024	Title: MAIN BOARD	
Design: RSS	7/18/2024	Model: 215	
Approve:		7/25/2024	Board#: 5110-211
Print Date: 7/25/2024	10:48:27 AM	Rev: 6	Sheet: 1 of 3
		Series	Sheet
		110	211

W:\Projects\LMM\215\5110-211\Rev6\110211R6P1.SchDoc

1

2

3

4

5

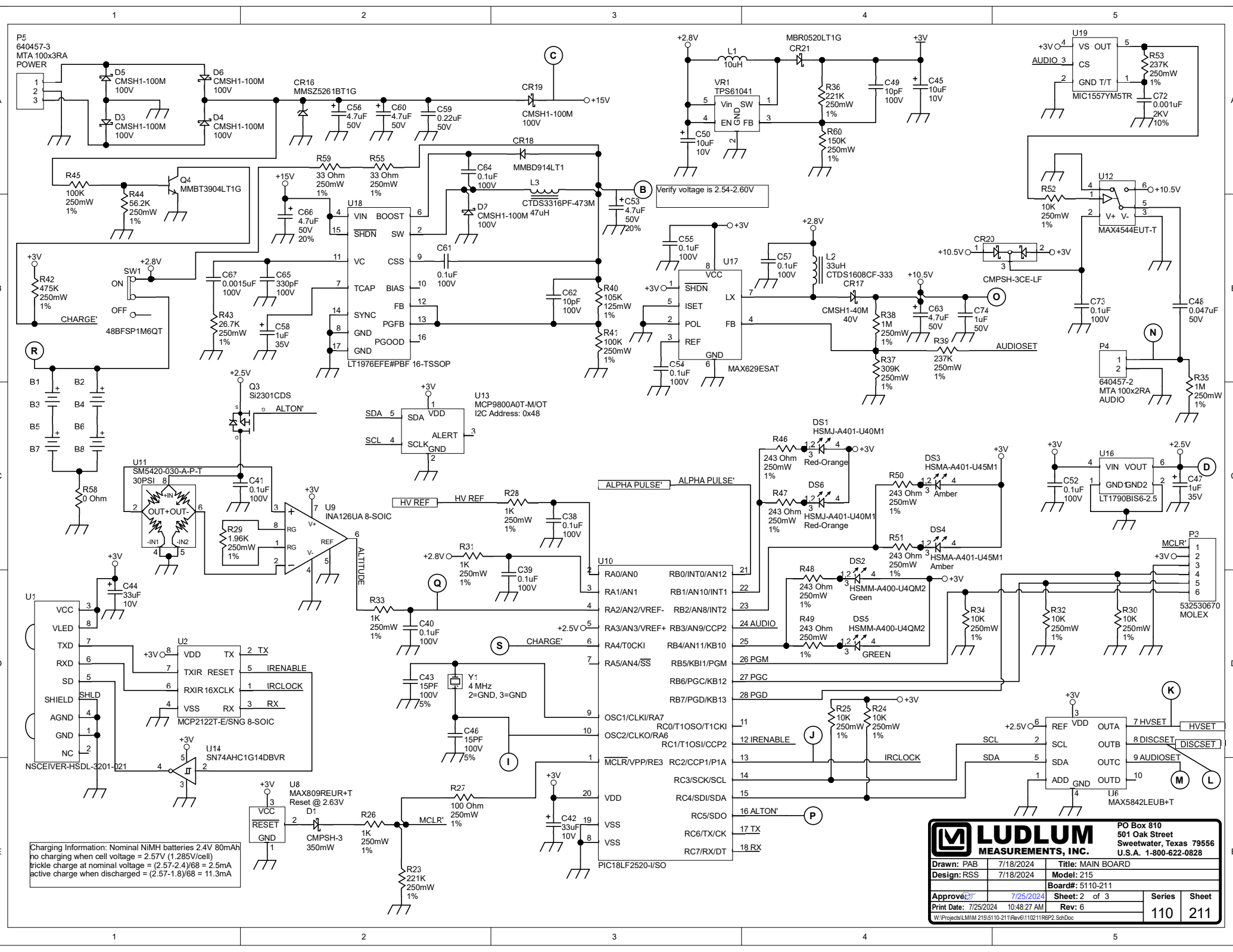

Charging Information: Nominal NiMH batteries 2.4V 80mAh
 no charging when cell voltage = 2.57V (1.285V/cell)
 trickle charge at nominal voltage = (2.57-2.4)/68 = 2.5mA
 active charge when discharged = (2.57-1.8)/68 = 11.3mA

		PO Box 810 501 Oak Street Sweetwater, Texas 79556 U.S.A. 1-800-622-0828	
		Drawn: PAB Design: RSS Approved: [Signature] Print Date: 7/25/2024	Title: MAIN BOARD Model: 215 Sheet#: 2 of 3 Rev: 6

W:\Projects\LMIM 215\5110-211\Rev6\110211R6P2 SchDoc

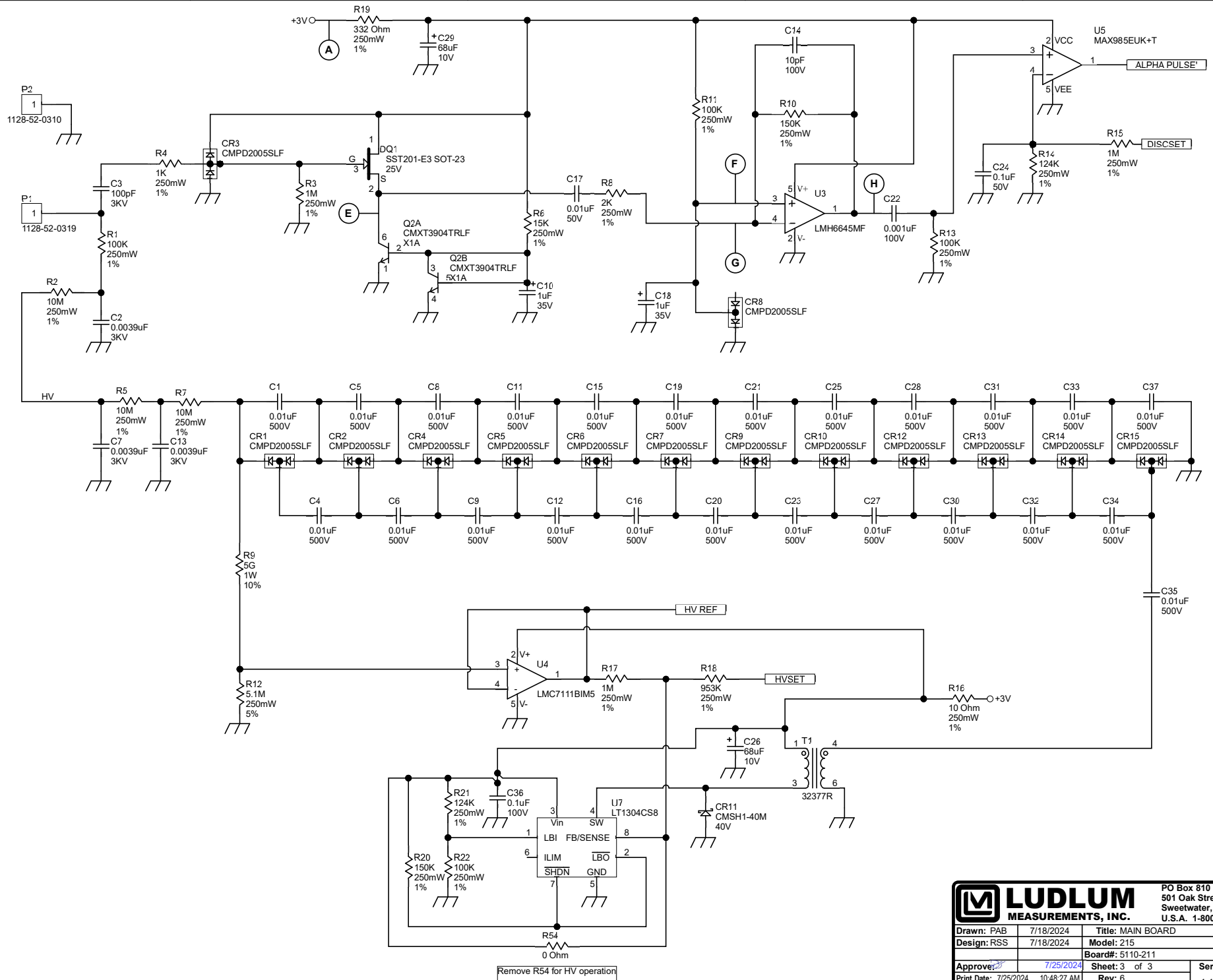

Remove R54 for HV operation

		PO Box 810 501 Oak Street Sweetwater, Texas 79556 U.S.A. 1-800-622-0828	
		Drawn: PAB Design: RSS Approve:	Title: MAIN BOARD Model: 215 Sheet: 3 of 3
Print Date: 7/25/2024 10:48:27 AM		Rev: 6	

W:\Projects\MM 215\110-211\Rev6\110211R6P3 SchDoc

A

B

C

D

1

1

2

2

TopLayer (Scale 1.12:1)

5110-211
Rev. 6

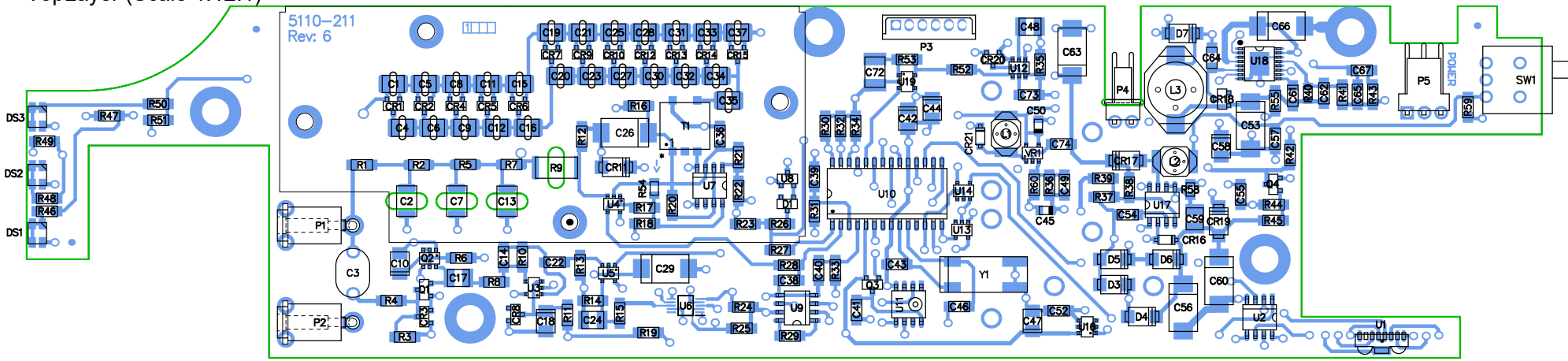

3

3

4

4

5

5

6

6

A

B

C

D

Part: 5110-211		Model: 215		
Desc: MAIN BOARD				
Design: RSS	Date: 7/18/2024	Rev:	6	
Drawn: PAB	Date: 7/18/2024	SHEET	SERIES	SHEET
Apr: <i>[Signature]</i>	Date: 7/25/2024	1 of 4	110	215
W:\Projects\LM\5110-211\Rev6\110211R6.PcbDoc				

Insert coin cell batteries with plus side up.

BottomLayer (Scale 1.12:1)

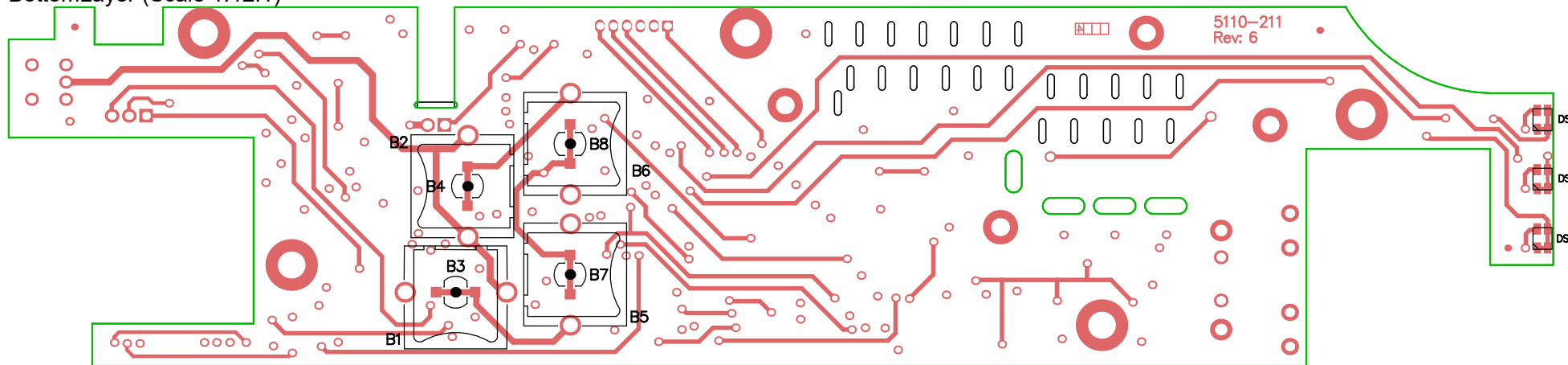

 LUDLUM MEASUREMENTS				
Part: 5110-211		Model: 215		
Desc: MAIN BOARD				
Design: RSS	Date: 7/18/2024	Rev:	6	
Drawn: PAB	Date: 7/18/2024	SHEET	SERIES	SHEET
Apr: JMC	Date: 7/26/2024	2 of 4	110	215
W:\Projects\LM\215\5110-211\Rev6\110211R6.PcbDoc				

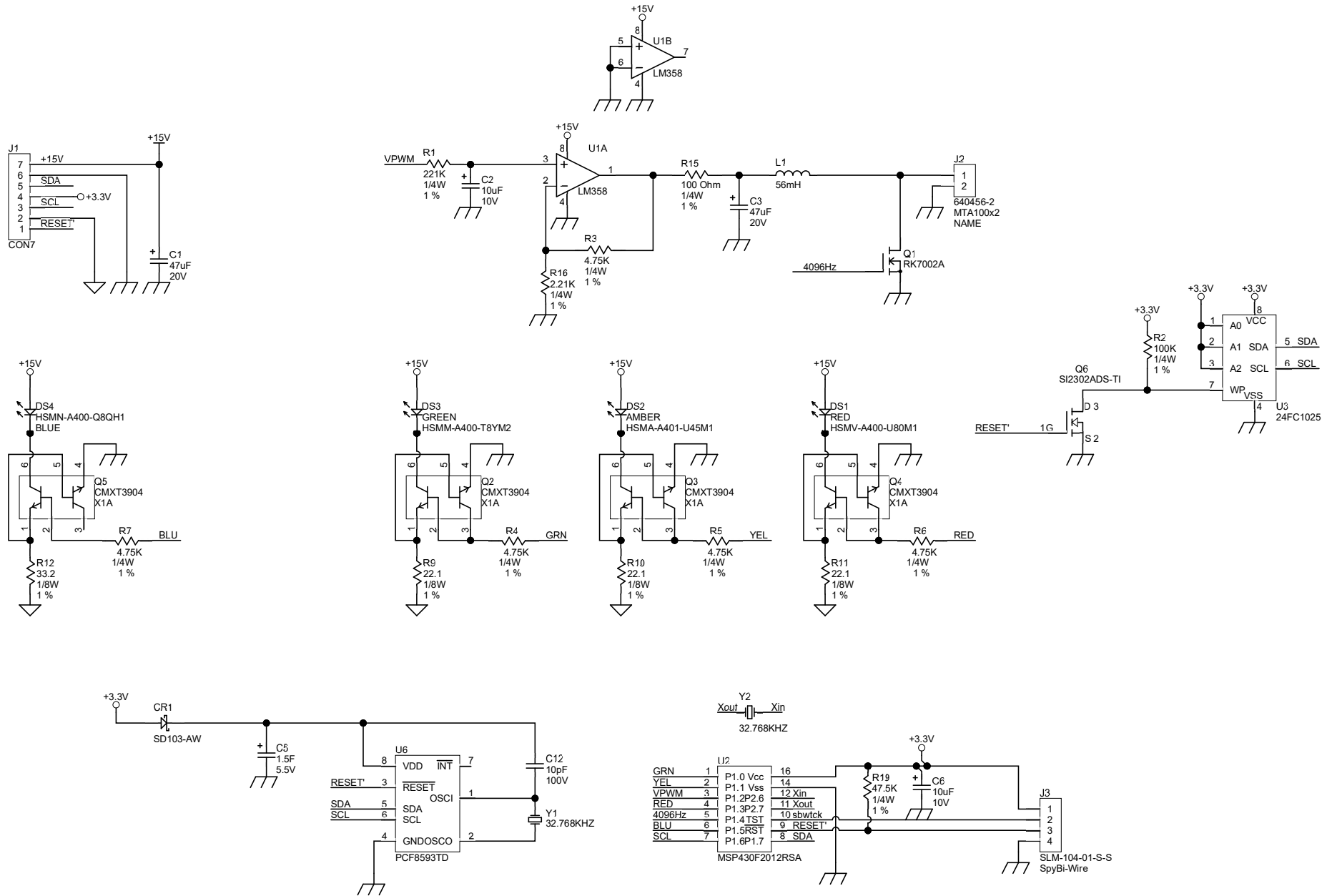

		PO Box 810 501 Oak Street Sweetwater, Texas 79556 U.S.A. 1-800-622-0828	
		Drawn: PAB Design: RDS Approved: Print Date: 2/19/2024 3:53:36 PM	Title: LED/AUDIO Model: 215-21 Sheet: 1 of 1 Rev: 4

A

B

C

D

1

2

3

4

5

6

TopLayer (Scale 2:1)

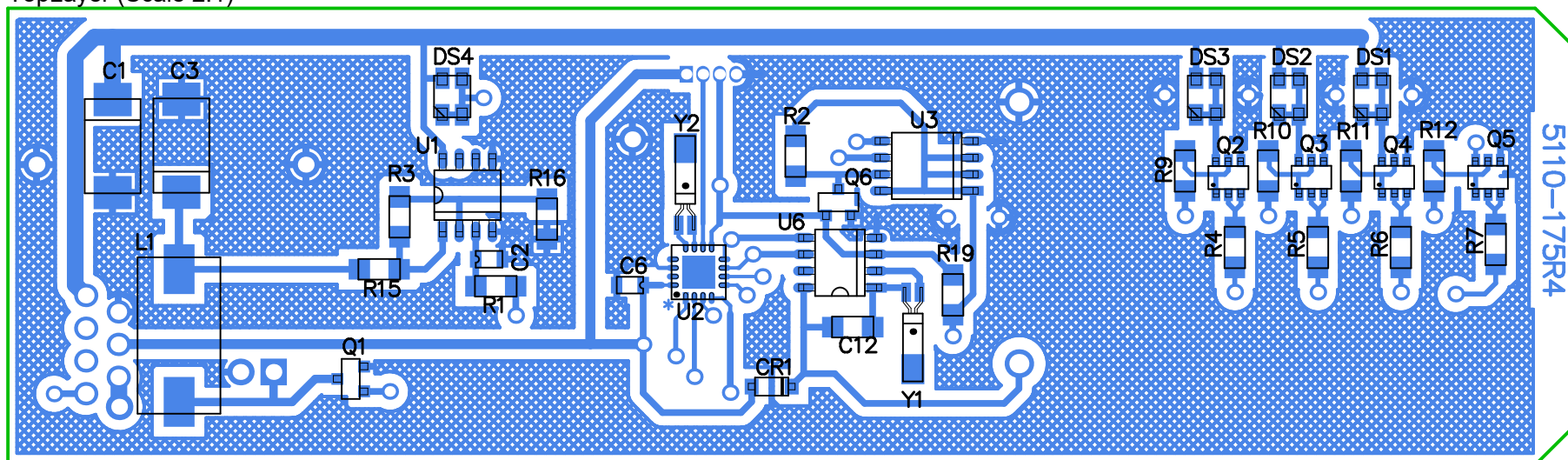

1

2

3

4

5

6

 LUDLUM MEASUREMENTS				
Part: 5110-175			Model: 215-21	
Desc: LED/AUDIO				
Design: RDS	Date: 05/05/2008		Rev:	4
Drawn: PAB	Date: 3/25/2024	SHEET	SERIES	SHEET
Apr: JMC	Date: 3/25/2024	1 of 3	110	176A
W:\Projects\LM\215-21\5110-175\Rev4				

A

B

C

D

A

B

C

D

1

1

2

2

3

3

4

4

5

5

6

6

BottomLayer (Scale 2:1)

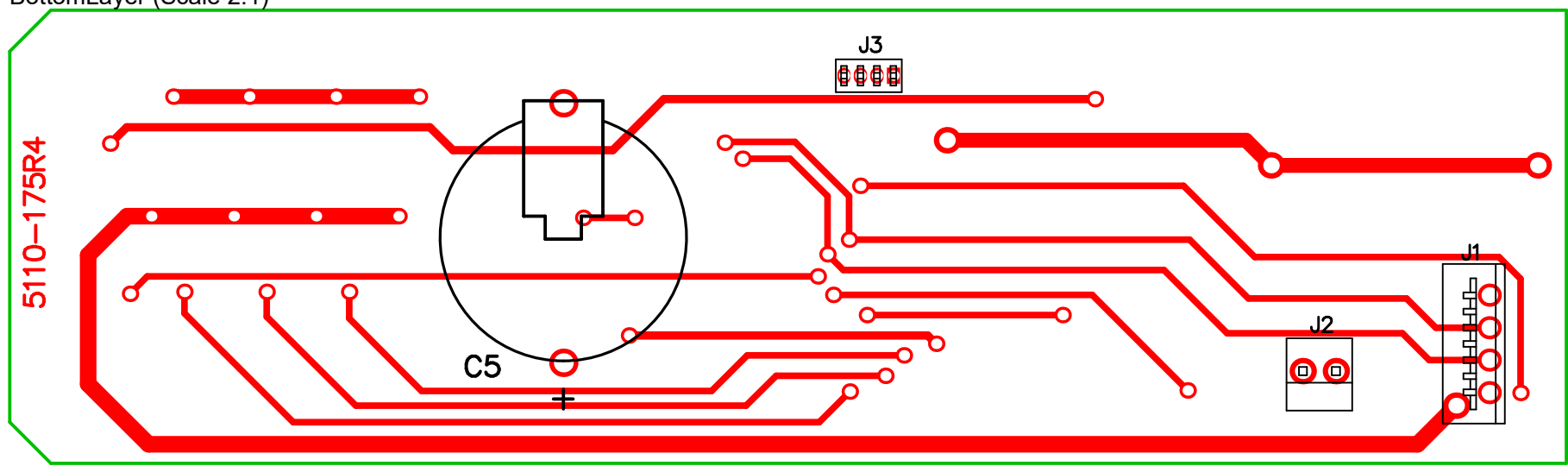

5110-175R4

 LUDLUM MEASUREMENTS				
Part: 5110-175		Model: 215-21		
Desc: LED/AUDIO				
Design: RDS	Date: 05/05/2008	Rev:	4	
Drawn: PAB	Date: 3/25/2024	SHEET	SERIES	SHEET
Apr: JMC	Date: 3/25/2024	2 of 3	110	176A
W:\Projects\LMIM 215-21\5110-175\Rev4				

A

B

C

D

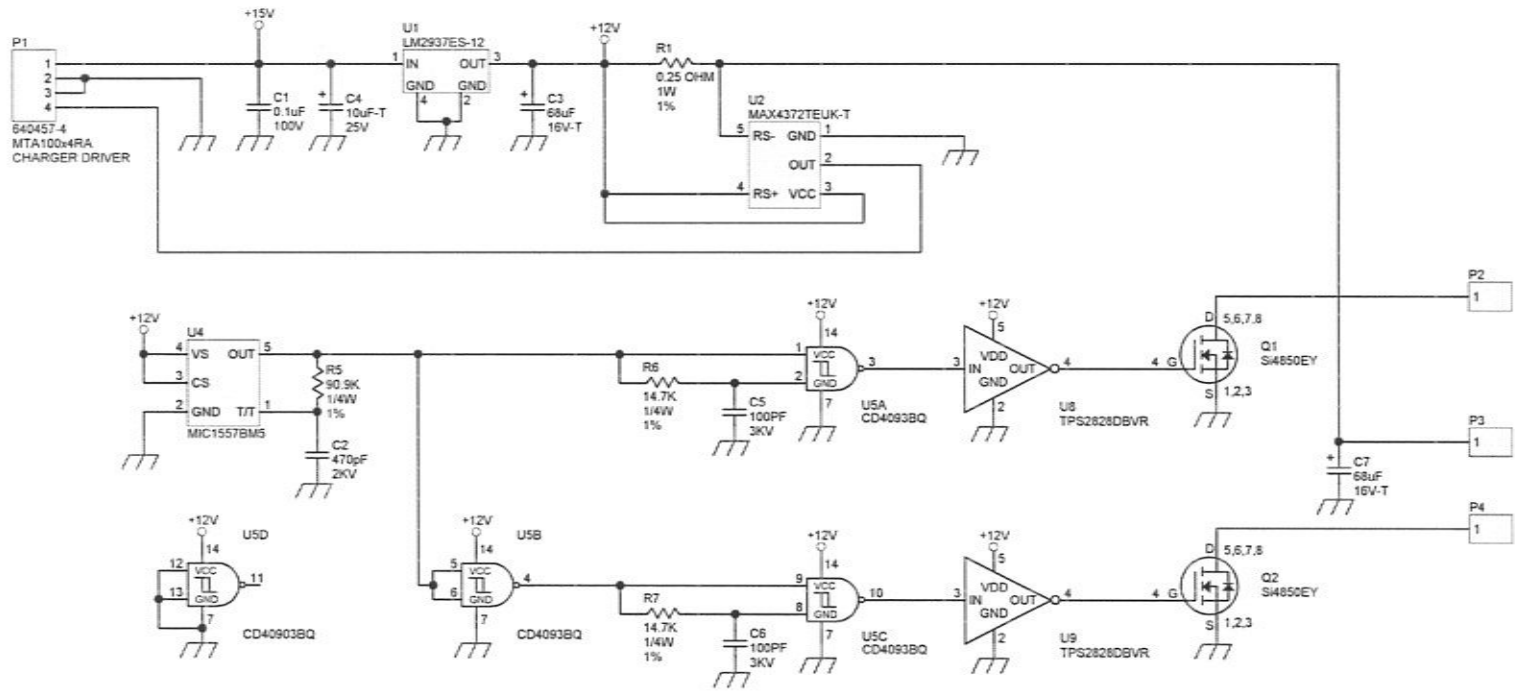

		PO Box 810 501 Oak Street Sweetwater, Texas 79556 U.S.A. 1-800-622-0828	
Drawn: SA	11/26/07	Title: CHARGER BOARD	
Design: LL	11/26/07	Model: 215-20	
		Board#: 5110-142	
Approve: <i>[Signature]</i>	15-40-18	Sheet: 1 of 1	Series
110142879: Sch	16-Sep-2008	Rev: 7.0	Sheet 110 142

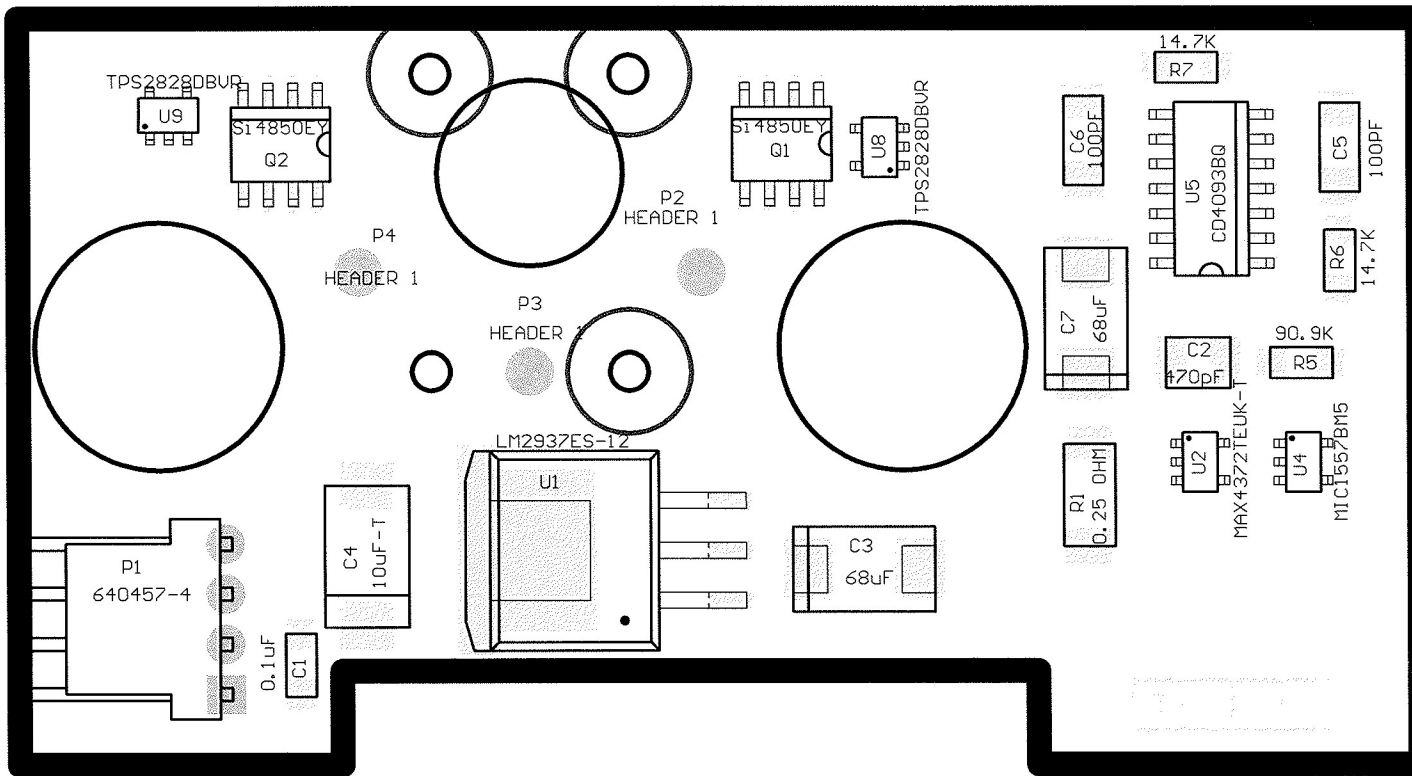

Drawn:	SA	11/26/07	Title:		
Design:	LL	11/26/07	CHARGER BOARD		
			Model: 215-20		
Approve:	<i>RSS</i>	<i>16 Sep 08</i>	Board#: 5110-142		
Layer: Mech.1	MID:		Rev: 7.0	Series	Sheet
	15:40:40	16-Sep-2008	SCALE: 2.59	110	143
110142R7X1.Pcb					

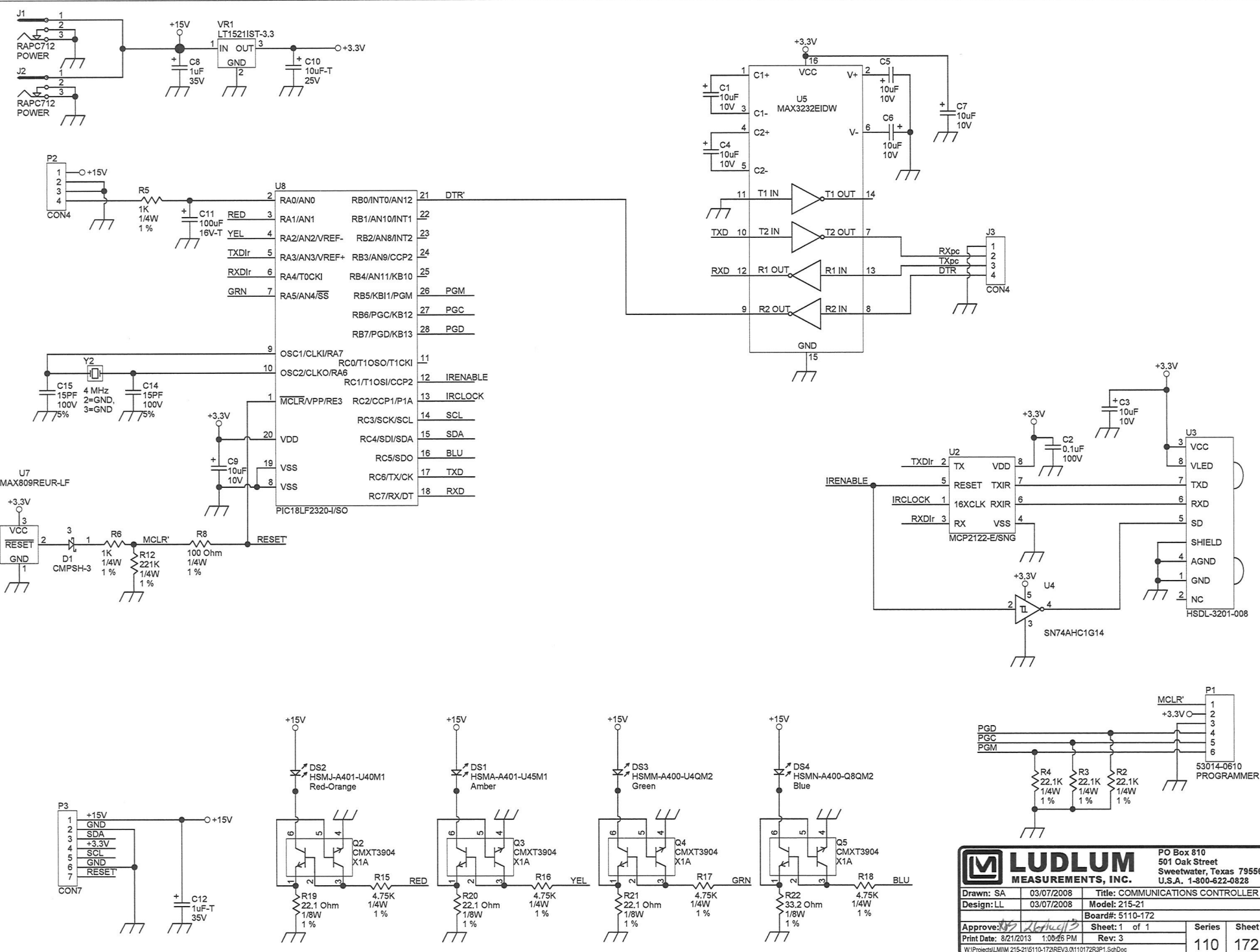

LUDLUM MEASUREMENTS, INC.
 PO Box 810
 501 Oak Street
 Sweetwater, Texas 79556
 U.S.A. 1-800-622-0828

Drawn: SA	03/07/2008	Title: COMMUNICATIONS CONTROLLER
Design: LL	03/07/2008	Model: 215-21
Board#: 5110-172		
Approved: <i>[Signature]</i>	Sheet: 1 of 1	Series
Print Date: 8/21/2013 1:00:26 PM	Rev: 3	Sheet
W:\Projects\LLMIM 215-21\5110-172\REV3.01\10172R3P1.SchDoc		110 172

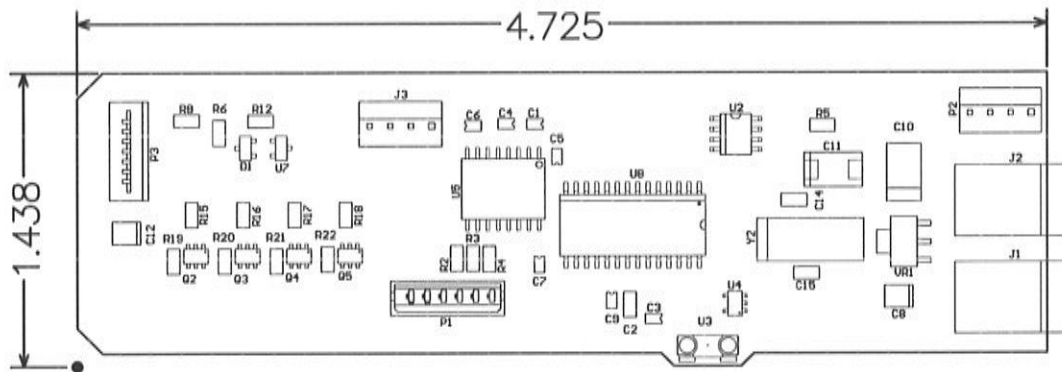

		PO Box 810 501 Oak Street Sweetwater, TX 79556 U.S.A. 1-800-622-0828	
		Title: COMMUNICATIONS CONTROLLER	
Drawn: SA	03/07/2008	Model: 215-21	
Design: LL	03/07/2008	Board#: 5110-172	
Approve: <i>LL</i>	<i>2/27/2013</i>	Rev: 3	
Print Date: 3/22/2013 8:24:32 AM		SCALE: 1.00 Top Overlay	Series 110 Sheet 173
<small>W:\Projects\LMM 215-215110-172\REV3.0\110172R3 Manual.PcbDoc</small>			

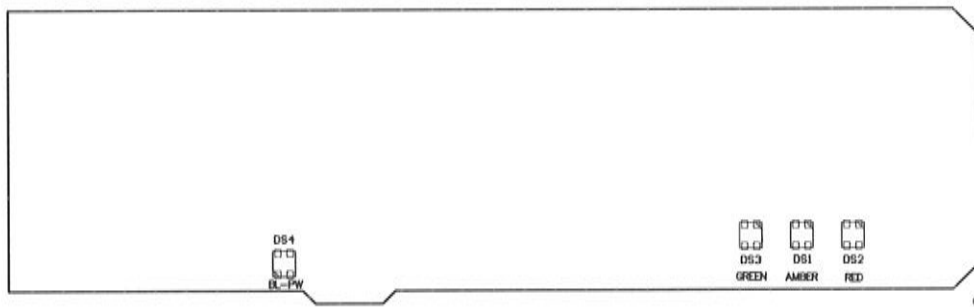

LUDLUM MEASUREMENTS, INC. PO Box 810
 501 Oak Street
 Sweetwater, TX 79556
 U.S.A. 1-800-622-0828

Title: COMMUNICATIONS CONTROLLER			
Drawn: SA	03/07/2008	Model: 215-21	
Design: LL	03/07/2008	Board#: 5110-172	
Approve: <i>RL</i>	<i>03/07/08</i>	Rev: 3	
Print Date:		SCALE: 1.00	Series
3/22/2013	8:24:33 AM	Bottom Overlay	Sheet 110 173