

---

**LUDLUM MODEL 19  
MICRO R METER**

**February 2012**

**Serial Number 207422 and Succeeding  
Serial Numbers**

---

**LUDLUM MODEL 19  
MICRO R METER**

**February 2012**

**Serial Number 207422 and Succeeding  
Serial Numbers**



**LUDLUM MEASUREMENTS, INC**  
501 OAK STREET, P.O. BOX 810  
SWEETWATER, TEXAS 79556  
325-235-5494, FAX: 325-235-4672

## **STATEMENT OF WARRANTY**

Ludlum Measurements, Inc. warrants the products covered in this manual to be free of defects due to workmanship, material, and design for a period of twelve months from the date of delivery. The calibration of a product is warranted to be within its specified accuracy limits at the time of shipment. In the event of instrument failure, notify Ludlum Measurements to determine if repair, recalibration, or replacement is required.

This warranty excludes the replacement of photomultiplier tubes, G-M and proportional tubes, and scintillation crystals which are broken due to excessive physical abuse or used for purposes other than intended.

There are no warranties, express or implied, including without limitation any implied warranty of merchantability or fitness, which extend beyond the description of the face there of. If the product does not perform as warranted herein, purchaser's sole remedy shall be repair or replacement, at the option of Ludlum Measurements. In no event will Ludlum Measurements be liable for damages, lost revenue, lost wages, or any other incidental or consequential damages, arising from the purchase, use, or inability to use product.

## **RETURN OF GOODS TO MANUFACTURER**

If equipment needs to be returned to Ludlum Measurements, Inc. for repair or calibration, please send to the address below. All shipments should include documentation containing return shipping address, customer name, telephone number, description of service requested, and all other necessary information. Your cooperation will expedite the return of your equipment.

**LUDLUM MEASUREMENTS, INC.  
ATTN: REPAIR DEPARTMENT  
501 OAK STREET  
SWEETWATER, TX 79556**

**800-622-0828 325-235-5494  
FAX 325-235-4672**

REV #	ALTERATIONS	DATE	BY
1	VALID	3/16/04	DDW
2	UPDATED BATTERY LID	8/14/06	CMC
3	UPDATED METERFACE	2/15/12	CMC

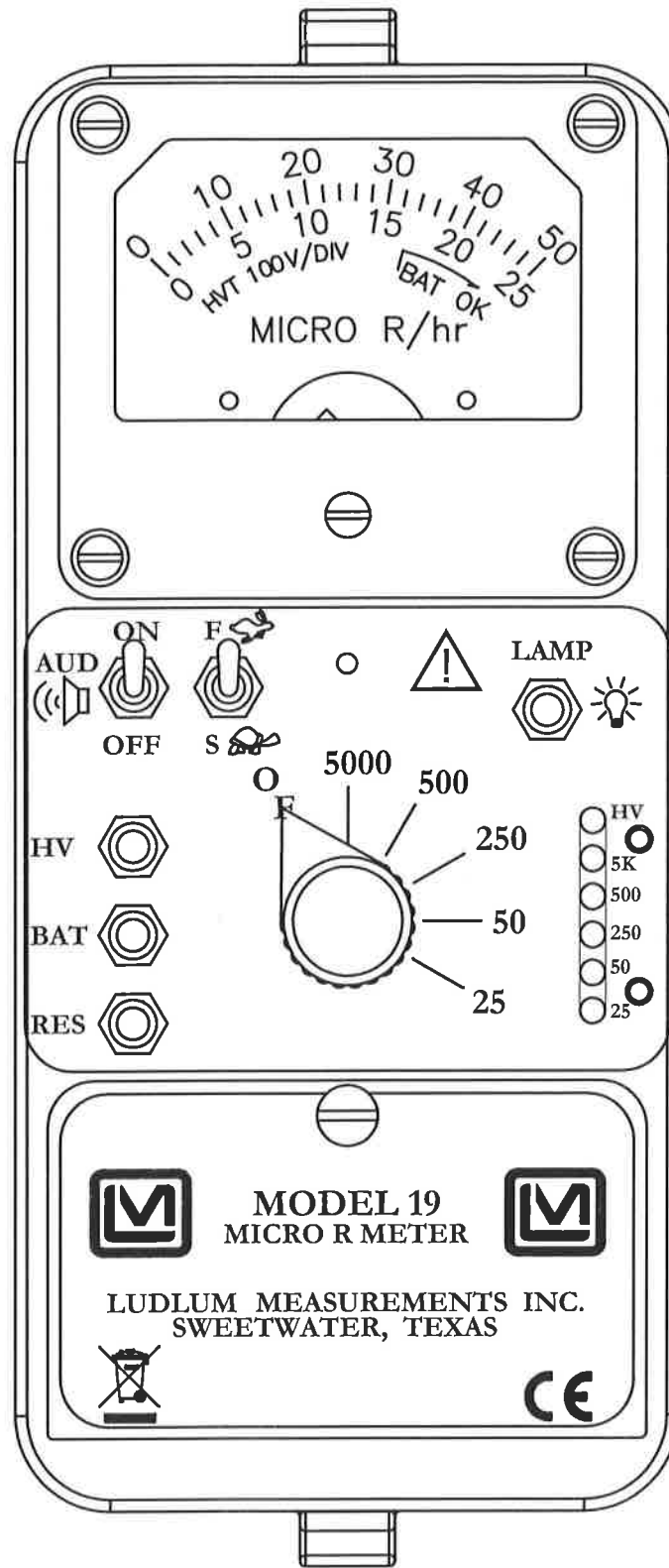

DWN	DATE	CHECKED	APPROVED
CMC	2/15/12		NBW 2-15-12
TITLE: MODEL 19 ASSY			
	LUDLUM MEASUREMENTS, INC. 501 OAK STREET SWEETWATER, TEXAS 79556	SERIES 367	SHEET 169

# Table of Contents

---

<i>Introduction</i>	<i>1</i>
<i>Getting Started</i>	<i>2</i>
Unpacking and Repacking	2-1
Battery Installation	2-1
Operational Check	2-2
Maintenance	2-3
Recalibration	2-3
Batteries	2-3
<i>Specifications</i>	<i>3</i>
<i>Identification of Controls and Functions</i>	<i>4</i>
<i>Safety Considerations</i>	<i>5</i>
Environmental Conditions for Normal Use	5-1
Warning Markings and Symbols	5-1
Cleaning and Maintenance Precautions	5-2
<i>Troubleshooting</i>	<i>6</i>
Troubleshooting Electronics which utilize a Scintillation Detector	6-1
<i>Technical Theory of Operation</i>	<i>7</i>
Detector	7-1
Input	7-1
Amplifier	7-1
Discriminator	7-1
Audio	7-2
Scale Ranging	7-2
Digital Analog Converter	7-2
Meter Drive	7-2
Fast/Slow Time Constant	7-2
Low Voltage Supply	7-2
High Voltage Test	7-2
High Voltage Supply	7-3

<i>Recycling</i>	<i>8</i>
<i>Parts List</i>	<i>9</i>
Model 19 Micro R Meter	9-1
Main Board, Drawing 367 × 166	9-1
Wiring Diagram, Drawing 367 × 174	9-4
<i>Drawings and Diagrams</i>	<i>10</i>

## Section

## 1

---

## Introduction

---

The Ludlum Model 19 Micro R Meter utilizes an internally-mounted 2.5 x 2.5 cm (1 × 1 in.) NaI(Tl) scintillator for optimum performance in locating and measuring low-level (near background) gamma radiation.

The unit features a push-button, lighted meter and was designed to be moisture and dust resistant. The meter is housed in a rugged aluminum bezel with waterproof seals. All controls, including a calibration potentiometer for each range, are located on the front panel. Front-panel switches are rubber-booted to seal out moisture and dust. A high-voltage (HV) test control is provided to allow rapid plateau testing of the detector.

Five range divisions are provided in the 0-5000 micro R/hr spectrum. The meter face is made up of two scales, 0-50 and 0-25, plus battery test. The 0-50 scale corresponds to the 50, 500 and 5000 positions on the range selector switch. The 0-25 scale corresponds to the 25 and 250 positions on the range selector switch.

The instrument is capable of using either standard "D" cell flashlight batteries or nickel-cadmium rechargeable batteries. However, the Model 19 does not include circuitry for recharging the batteries. The two "D" cell batteries are located in an isolated compartment, easily accessible from the front panel.

The Model 19 NaI scintillator is energy sensitive. An energy response curve is included in section 10 of this manual for further reference.

## Section

## 2

## Getting Started

---

### Unpacking and Repacking

Remove the calibration certificate and place it in a secure location. Remove the instrument and accessories (batteries, cable, etc.) and ensure that all of the items listed on the packing list are in the carton. Check individual item serial numbers and ensure calibration certificates match. The Model 19 serial number is located on the front panel below the battery compartment. Most Ludlum Measurements, Inc. detectors have a label on the base or body of the detector for model and serial number identification.

**Important!**

If multiple shipments are received, ensure that the detectors and instruments are not interchanged. Each instrument is calibrated to specific detectors, and therefore, not interchangeable.

To return an instrument for repair or calibration, provide sufficient packing material to prevent damage during shipment. Also provide appropriate warning labels to ensure careful handling. Include detector(s) and related cable(s) for calibration. Include brief information as to the reason for return, as well as return shipping instructions:

- **Return shipping address**
- **Customer name or contact**
- **Telephone number**
- **Description of service requested and all other necessary information**

### Battery Installation

Ensure the Model 19 power switch is in the “OFF” position. Open the battery lid by pushing down and turning the quarter-turn thumbscrew counterclockwise a quarter of a turn. Install two "D" size batteries in the compartment.



Note the (+) and (-) marks inside the battery door. Match the battery polarity to these marks. Close the battery box lid, push down and turn the quarter-turn thumb screw clockwise a quarter of a turn.

**Note:**

Center post of a flashlight battery is positive. The batteries are placed in the battery compartment in opposite directions.

## Operational Check

Turn the range selector switch to the “25” position. Depress the “BAT” pushbutton switch and ensure that the meter needle falls within the “BAT OK” marks. Check for a proper background reading. A typical reading would be: 5-15 uR/hr

Turn the range selector switch to the “5000” position. Expose the instrument to a check source and verify that the instrument indicates within 20% of the check source reading obtained during the last calibration.

Switch the “AUD ON/OFF” switch to the “ON” position and confirm that the external unimorph speaker produces an audible click for each event detected. The “AUD ON/OFF” switch will silence the audible clicks if in the “OFF” position. It is recommended that the “AUD ON/OFF” switch be kept in the “OFF” position when not needed in order to preserve battery life.

Turn the range selector switch to the “250” position and increase the source activity for a meter reading of 10-100 uR/hr. While observing the meter fluctuations, select between the fast and slow response time (F/S) positions to observe variations in the display. The “S” position should respond approximately five times slower than the “F” position.

**Note:**

The slow response position is normally used when the instrument is displaying low numbers, which require a more stable meter movement. The fast response position is used at high rate levels.

Check the meter reset function by depressing RESET and ensuring the meter needle drops to “0.”

Depress the “LAMP” pushbutton switch. Ensure that the meter face illuminates when the switch is depressed. Proceed to use the instrument.

## Maintenance

Instrument maintenance consists of keeping the instrument clean and periodically checking the batteries and the calibration. The Model 19 instrument may be cleaned with a damp cloth (using only water as the wetting agent). Do not immerse instrument in any liquid. Observe the following precautions when cleaning:

1. Turn the instrument off and remove the batteries.
2. Allow the instrument to sit for one minute before accessing internal components.

### *Recalibration*

Recalibration should be accomplished after any maintenance or adjustment of any kind has been performed on the instrument. Battery replacements are not considered maintenance and do not normally require instrument recalibration.

#### Note:

Ludlum Measurements, Inc. recommends recalibration at intervals no greater than one year. Check the appropriate regulations to determine required recalibration intervals.

Ludlum Measurements offers a full-service repair and calibration department. We not only repair and calibrate our own instruments but most other manufacturers' instruments. Calibration procedures are available upon request for customers who choose to calibrate their own instruments.

### *Batteries*

The batteries should be removed any time the instrument is placed into storage. Battery leakage may cause corrosion on the battery contacts, which must be scraped off and/or washed using a paste solution made from baking soda and water. Use a spanner wrench to unscrew the battery contact

insulators, exposing the internal contacts and battery springs. Removal of the handle will facilitate access to these contacts.

Note:

Never store the instrument over 30 days without removing the batteries. Although this instrument will operate at very high ambient temperatures, battery seal failure may occur at temperatures as low as 37 °C (100 °F).

---

## Section

## 3

## Specifications

---

Linearity: reading within 10% of true value

High Voltage: variable from 400 to 1500 Vdc; electronically regulated to within 1%

Battery Dependence: instrument calibration change less than 3% within the meter battery check limits

Power: two standard alkaline "D" cell batteries, secured in an isolated compartment

Battery Life: expected lifetime of approximately 2000 hours with the "AUD ON/OFF" switch in the OFF position

Audio Output: built-in unimorph speaker and "ON/OFF" switch provided on the front panel

Counting Ranges: two-scale meter face presenting 0-50  $\mu\text{R/hr}$  with full scale range positions of 5000, 500 and 50; and 0-25  $\mu\text{R/hr}$  with full scale range positions of 250 and 25.

Meter: 1 mA, 6.4 cm (2.5 in.) scale, pivot-and-jewel suspension

Detector: photomultiplier coupled to a 2.5 x 2.5 (1 × 1 in.) NaI(Tl) crystal, mounted inside the instrument housing

Construction: cast-and-drawn aluminum with beige powder-coat finish and printed membrane front panel

Size: 15.2 x 8.9 x 21.6 cm (6.0 x 3.5 x 8.5 in.), not including instrument handle

Weight: 2.04 kg (4.5 lb), including batteries

## Section

## 4

## Identification of Controls and Functions

---

Range Selector Switch: a six-position switch marked OFF, 5000, 500, 250, 50, and 25. Moving the range selector switch to one of the range positions (5000, 500, 250, 50, 25) provides the operator with an overall range of 0-5000  $\mu\text{R/hr}$ . Note that the range positions 5000, 500 and 50 are screened in black and correspond to the meter scale screened in black. The range positions 250 and 25 are screened in red and correspond to the meter scale screened in red.

AUD ON-OFF Toggle Switch: In the ON position, the switch operates the unimorph speaker, located on the left side of the instrument. The frequency of the clicks is relative to the rate of the incoming pulses. The higher the rate is, the higher the audio frequency. The audio should be turned OFF when not required in order to reduce battery drain.

F-S Toggle Switch: provides meter response. Selecting the fast, "F," position of the toggle switch provides 90% of full-scale meter deflection in four seconds. In the slow, "S," position, 90% of full-scale meter deflection takes 22 seconds. In "F" position, there is fast response and large meter deviation. The "S" position should be used for slow response and damped, meter deviation.

BAT Pushbutton Switch: when depressed, this switch indicates the battery charge status on the meter. The range selector switch must be out of the OFF position.

RES Pushbutton Switch: When depressed, this switch provides a rapid means to drive the meter to zero.

LAMP Pushbutton Switch: When depressed, this switch lights the meter face.

HV Pushbutton Switch: When depressed, the meter reads the detector high voltage. Each meter division is equivalent to 100 V.

HV Adjustment: provides a means to vary the high voltage from 400 to 1500 V.

Range Calibration Adjustments: recessed potentiometers located under the calibration cover on the right side of the front panel. These adjustment controls allow individual calibration for each range multiplier.

Section

5

## Safety Considerations

---

### Environmental Conditions for Normal Use

Indoor or outdoor use

No maximum altitude

Temperature range of -20 to 50 °C (-4 to 122 °F)

Maximum relative humidity of less than 95% (non-condensing)

Pollution Degree 3 (as defined by IEC 664) (Occurs when conductive pollution or dry nonconductive pollution becomes conductive due to condensation. This is typical of industrial or construction sites.)

### Warning Markings and Symbols

#### Caution!

The operator or responsible body is cautioned that the protection provided by the equipment may be impaired if the equipment is used in a manner not specified by Ludlum Measurements, Inc.

The Model 19 Micro R Meter is marked with the following symbols:



**CAUTION** (per ISO 3864, No. B.3.1) – designates hazardous live voltage and risk of electric shock. During normal use, internal components are hazardous live. This instrument must be isolated or disconnected from the hazardous live voltage before accessing the internal components. This symbol appears on the front panel. **Note the following precautions:**

**Warning!**

The operator is strongly cautioned to take the following precautions to avoid contact with internal hazardous live parts that are accessible using a tool:

1. Turn the instrument power OFF and remove the batteries.
2. Allow the instrument to sit for one minute before accessing internal components.



The “**crossed-out wheellie bin**” symbol notifies the consumer that the product is not to be mixed with unsorted municipal waste when discarding; each material must be separated. The symbol is placed on the battery compartment lid. See section 8, “Recycling,” for further information.



The “CE” mark is used to identify this instrument as being acceptable for use within the European Union.

## Cleaning and Maintenance Precautions

The Model 19 may be cleaned externally with a damp cloth, using only water as the wetting agent. Do not immerse the instrument in any liquid. Observe the following precautions when cleaning or performing maintenance on the instrument:

1. Turn the instrument OFF and remove the batteries.
2. Allow the instrument to sit for one minute before cleaning the exterior or accessing any internal components for maintenance.



Section

6

## Troubleshooting

---

Occasionally, you may encounter problems with your LMI instrument or detector that may be repaired or resolved in the field, saving turn-around time and expense in returning the instrument to us for repair. Toward that end, LMI electronics technicians offer the following tips for troubleshooting the most common problems. Where several steps are given, perform them in order until the problem is corrected. Keep in mind that with this instrument, the most common problems encountered are: (1) sticky meters; and (2) battery contacts.

Note that the first troubleshooting tip is for determining whether the problem is with the electronics or with the detector. A Ludlum Model 500 Pulser is invaluable at this point, because of its ability to simultaneously check high voltage, input sensitivity or threshold, and the electronics for proper counting.

We hope these tips will prove to be helpful. As always, please call if you encounter difficulty in resolving a problem or if you have any questions.

### Troubleshooting Electronics which utilize a Scintillation Detector

**SYMPTOM**

No power (or meter does not reach BAT TEST or BAT OK mark)

**POSSIBLE SOLUTION**

1. Check batteries and replace if weak.
2. Check polarity (see marks inside batter lid). Are the batteries installed backwards?

<b><u>SYMPTOM</u></b>	<b><u>POSSIBLE SOLUTION</u></b>
No power (or meter does not reach BAT TEST or BAT OK mark) (continued)	<ol style="list-style-type: none"><li>3. Check battery contacts. Clean them with rough sandpaper or use an engraver to clean the tips.</li><li>4. Check for loose or broken wires, especially between the main board and the calibration board.</li></ol>
Nonlinear Readings	<ol style="list-style-type: none"><li>1. Check the high voltage (HV) by pressing the HV TEST button. If a multimeter is used to check the HV, ensure that one with high impedance is used, as a standard multimeter could be damaged in this process.</li><li>2. Check for “sticky” meter movement. Does the reading change when you tap the meter? Does the meter needle “stick” at any spot?</li><li>3. Check the “meter zero.” Turn the power OFF. The meter should come to rest on “0.”</li></ol>
Meter goes full-scale or “pegs out”	<ol style="list-style-type: none"><li>1. Check the HV and, if possible, the input threshold for proper setting.</li><li>2. Check for loose wires, especially between the main board and the calibration board.</li></ol>

## Section

## 7

## Technical Theory of Operation

---

### Detector

The detector consists of a crystal of sodium iodide with Thallium activation (NaI Tl) that gives off light pulses when penetrated by radiation photons.

The light pulses are converted to electrical pulses by the photo cathode of the photomultiplier tube. The photomultiplier includes a nine-stage electron amplifier. This amplifier utilizes an electrostatic field for each stage, adding up to a required 500 to 1500 V supply.

### Input

Detector pulses are coupled from the detector through C6 to the amplifier. CR1 protects the amplifier from input shorts. R37 couples the detector to the high-voltage supply.

### Amplifier

A self-biased amplifier provides gain in proportion to R15 and C4 divided by R14. Transistor (pin 3 of U4) provides amplification. U6 is configured as a current mirror to provide a load for pin 3 of U4. The output self biases to 2 V<sub>be</sub> (approximately 1.4 volts) at emitter of Q1. This provides just enough bias current through pin 3 of U4 to conduct all of the current from the current mirror.

Positive pulses at R16 are coupled to the discriminator through C5.

### Discriminator

Comparator U8 provides discrimination. The discriminator is set by the voltage divider, R21 and R23, coupled to pin 3 of U8. U8 output pulses are coupled to pin 5 of U9A for meter drive and pin 12 of U9B for audio.

## Audio

Discriminator pulses are coupled to univibrator pin 12 of U9B. Front-panel audio ON-OFF selector controls the reset at pin 13 of U9B. When ON, pulses from pin 10 of U9B turn on oscillator U12, which drives the can-mounted unimorph. Speaker tone is set by R31, C14; duration by R22, C7.

## Scale Ranging

Detector pulses from the discriminator are coupled to univibrator pin 5 of U9A. For each scale, the pulse width of pin 6 of U9A is controlled by the front-panel calibration controls and their related capacitors. This arrangement allows the same current to be delivered to C9 in proportion to the meter reading.

## Digital Analog Converter

U5 is configured as a current mirror. For each pulse of current through R24, an equal current is delivered to C9. This charge is drained off by R25. The voltage across C9 is proportional to the incoming count rate.

## Meter Drive

The meter is driven by the collector of Q2 coupled as a voltage follower in conjunction with pin 1 of U10.

For the battery test, the voltage follower is bypassed and the meter movement is directly coupled to the battery through R8.

## Fast/Slow Time Constant

For slow-time constant, C17 is switched from the output of the meter drive to parallel C9.

## Low Voltage Supply

Battery voltage is coupled to U11 and associated components (a switching regulator) to provide 5 V at pin 8 to power all circuits.

## High Voltage Test

A constant current is developed by collector of Q3 in proportion to HV signal at pin 1 of U17. U16 provides a current mirror to drive the meter

through analog switch logic circuit U15, U14, and U3.

## High Voltage Supply

High voltage is developed by switching regulator U13 and T1. Voltage multiplier CR3 thru CR7, and associated components, develop the detector voltage. Voltage feedback is provided by R39 thru U17 to feed back pin 8 of U13 for voltage regulation. Pin 1 of U17 is proportional to the high voltage, and its output is also utilized to measure the high voltage. High voltage is adjusted by varying the feedback current with R42.

## Section

## 8

---

## Recycling

---

Ludlum Measurements, Inc. supports the recycling of the electronics products it produces for the purpose of protecting the environment and to comply with all regional, national, and international agencies that promote economically and environmentally sustainable recycling systems. To this end, Ludlum Measurements, Inc. strives to supply the consumer of its goods with information regarding reuse and recycling of the many different types of materials used in its products. With many different agencies – public and private – involved in this pursuit, it becomes evident that a myriad of methods can be used in the process of recycling. Therefore, Ludlum Measurements, Inc. does not suggest one particular method over another, but simply desires to inform its consumers of the range of recyclable materials present in its products, so that the user will have flexibility in following all local and federal laws.

The following types of recyclable materials are present in Ludlum Measurements, Inc. electronics products, and should be recycled separately. The list is not all-inclusive, nor does it suggest that all materials are present in each piece of equipment:

Batteries	Glass	Aluminum and Stainless Steel
Circuit Boards	Plastics	Liquid Crystal Display (LCD)

Ludlum Measurements, Inc. products, which have been placed on the market after August 13, 2005, have been labeled with a symbol recognized internationally as the “crossed-out wheelie bin.” This notifies the consumer that the product is not to be mixed with unsorted municipal waste when discarding; each material must be separated. The symbol will be placed near the AC receptacle, except for portable equipment where it will be placed on the battery lid.

The symbol appears as such:



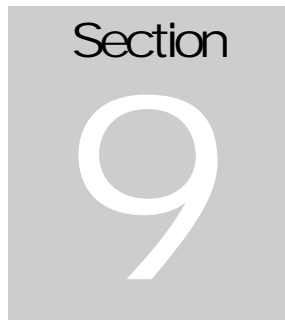

## Parts List

---

	<u>Reference</u>	<u>Description</u>	<u>Part Number</u>
Model 19 Micro R Meter	UNIT	Completely Assembled Model 19 Micro R Meter	48-1615
Main Board, Drawing 367 × 166	BOARD	Completely Assembled Circuit Board	5367-166
CAPACITORS			
	C1	47pF, 100V	04-5660
	C2	0.0022 $\mu$ F, 50V	04-5676
	C3	0.001 $\mu$ F, 100V	04-5659
	C4	10pF, 100V	04-5673
	C5	0.01 $\mu$ F, 50V	04-5664
	C6	100pF, 3KV	04-5735
	C7	0.022 $\mu$ F, 50V	04-5667
	C8	1 $\mu$ F, 16V	04-5701
	C9	10 $\mu$ F, 25V	04-5655
	C10	100pF, 100V	04-5661
	C11	68 $\mu$ F, 10V	04-5654
	C12	10 $\mu$ F, 25V	04-5728
	C14	470pF, 100V	04-5668
	C17	47 $\mu$ F, 10V	04-5666
	C18-C27	0.01 $\mu$ F, 500V	04-5696
	C28	0.001 $\mu$ F, 2KV	04-5703
	C29	68 $\mu$ F, 10V	04-5654
	C30-C31	1 $\mu$ F, 16V	04-5701
	C32	270pF, 100V	04-5679
	C33	0.01 $\mu$ F, 50V	04-5664

	<u>Reference</u>	<u>Description</u>	<u>Part Number</u>
TRANSISTORS	Q1	MMBT3904LT1	05-5841
	Q2	MMBT4403LT1	05-5842
	Q3	MMBT3904LT1	05-5841
VOLTAGE REGULATOR	VR1	LT1460KCS3-2.5TR	05-5867
INTEGRATED CIRCUITS	U1-U3	MAX4542ESA	06-6453
	U4-U5	CMXT3904	05-5888
	U6	CMXT3906	05-5890
	U7	MAX4541ESA	06-6452
	U8	MAX985EUK-T	06-6459
	U9	CD74HC4538M	06-6297
	U10	LMC7111BIM5X	06-6410
	U11	LT1304CS8-5	06-6434
	U12	MIC1557BM5	06-6457
	U13	LT1304CS8	06-6394
	U14-U15	MAX4542ESA	06-6453
	U16	CMXT3906	05-5890
	U17-C18	LMC7111BIM5X	06-6410
	DIODES	CR1	CMPD2005S
CR2		CMSH1-40M	07-6411
CR3-CR7		CMPD2005S	07-6468
CR9		CMSH1-40M	07-6411
SWITCHES	SW1	RANGE SELECTOR	08-6761
	SW2	H.V. PUSHBUTTON	08-6770
	SW3	F-S TOGGLE	08-6781
	SW4	AUD ON-OFF TOGGLE	08-6781
	SW5	RES PUSHBUTTON	08-6770
	SW6	LAMP PUSHBUTTON	08-6770
	SW7	BAT PUSHBUTTON	08-6770
POTENTIOMETERS / TRIMMERS	R33	1M, 64W105 NAME	09-6814
	R34	1M, 64W105 X10	09-6814
	R35	1M, 64W105 X1	09-6814
	R36	1M, 64W105 X0.1	09-6814
	R41	100K, 64W104 X100	09-6813



	<u>Reference</u>	<u>Description</u>	<u>Part Number</u>
	R42	100K, 64W104 HV ADJ	09-6813
	R52	10K, 3266X1-103 NAME	09-6822
RESISTORS			
	R1-R5	200K, 1/8W, 1%	12-7992
	R6	8.25K, 1/8W, 1%	12-7838
	R7	10K, 1/8W, 1%	12-7839
	R8	2.37K, 1/8W, 1%	12-7861
	R9-R11	10K, 1/8W, 1%	12-7839
	R12	200 Ohm, 1/8W, 1%	12-7846
	R13	10K, 1/8W, 1%	12-7839
	R14	4.75K, 1/8W, 1%	12-7858
	R15	200K, 1/8W, 1%	12-7992
	R16	10K, 1/8W, 1%	12-7839
	R17	1K, 1/8W, 1%	12-7832
	R18	4.75K, 1/8W, 1%	12-7858
	R19	2K, 1/8W, 1%	12-7926
	R20-R21	100K, 1/4W, 1%	12-7834
	R22	1M, 1/8W, 1%	12-7844
	R23	2.49K, 1/8W, 1%	12-7999
	R24	14.7K, 1/8W, 1%	12-7068
	R25	200K, 1/4W, 1%	12-7992
	R26	100K, 1/4W, 1%	12-7834
	R27	68.1K, 1/8W, 1%	12-7881
	R28	100K, 1/8W, 1%	12-7834
	R29	1K, 1/8W, 1%	12-7832
	R30	100K, 1/8W, 1%	12-7834
	R31	475K, 1/8W, 1%	12-7859
	R32	100K, 1/8W, 1%	12-7834
	R37	100K, 1/8W, 1%	12-7834
	R38	4.75M, 1/8W, 1%	12-7995
	R39	500M, 3KV, 2%	12-7031
	R40	1M, 1/4W, 1%	12-7844
	R44	1K, 1/4W, 1%	12-7832
	R45	8.25K, 1/8W, 1%	12-7838
	R46-R48	200K, 1/4W, 1%	12-7992
	R49	825K, 1/8W, 1%	12-7005
	R50	953K, 1/8W, 1%	12-7950
	R53	1K, 1/4W, 1%	12-7832
CONNECTORS			
	P1	CONN-640456-4 MTA100x4 NAME	13-8088

	<u>Reference</u>	<u>Description</u>	<u>Part Number</u>
	P2	CONN-640456-3 MTA100x3 NAME	13-8081
	P3	CONN-640456-2 MTA100x2 NAME	13-8073
	P4	CONTACT #1434 NAME	18-9124
INDUCTOR			
	L1	22 $\mu$ H, CD43-220	21-9808
TRANSFORMER			
	T1	31032R	21-9925
Wiring Diagram, Drawing 367 $\times$ 174 AUDIO			
	DS1	Model 19 LAMP BOARD 5367-113	5367-113
	DS2	UNIMORPH TEC-3526-PU	21-9251
CONNECTOR			
	P1	MTA100x4 MAIN BOARD 5367-166	13-8170
	P2	MTA 100x3 MAIN BOARD 5367-166	13-8135
	P3	MTA 100x2 MAIN BOARD 5367-166	13-8178
BATTERY			
	B1-B2	DURACELL "D"	21-9313
MISCELLANEOUS			
	*	MODEL 19 INTERNAL DETECTOR	47-3426
	*	TUBE/XTAL ASSY	2004-061
	M1	MODEL 19 METER ASSY 987010-001 1mA	4367-024
	*	MODEL 19 METERFACE (202-016)	7367-023
	*	METER BEZEL W/ GLASS W/ SCREWS	4363-352-00
	*	METER MOVEMENT (1mA)	15-8030
	*	Model 19 BATTERY BOX LID W/CNTCT	2363-191
	*	DEEP PORTABLE CAN ASSY	4363-615
	*	MODEL 19 CASTING	7367-171
	*	MODEL 19 MAIN HARNESS	8367-170

---

<u>Reference</u>	<u>Description</u>	<u>Part Number</u>
*	PORTABLE KNOB	08-6613
*	SWITCH SEAL (P/B)	08-6611
*	UNIMORPH W/WIRES, O'RING	40-0034
*	CAL COVER W/SCREWS	4363-200
*	HANDLE- PORTABLE (GRIP)	7363-139

Section  
10

## Drawings

---

Model Board Circuit, Drawing 367 × 166 (4 sheets)

Model Board Component Layouts, Drawings 367 × 167 (2 sheets)

Wiring Diagram, Drawing 367 × 174

Energy Response for Ludlum Model 19

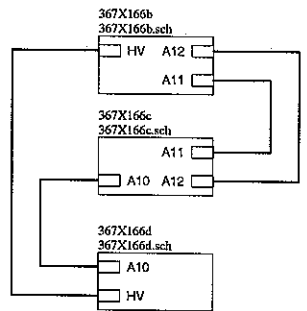

<b>LUDLUM</b>		PO Box 810	
<b>MEASUREMENTS, INC.</b>		501 Oak Street	
		Sweetwater, Texas 79556	
		U.S.A. 1-800-622-0828	
Drawn: JK	04-MAR-04	Title: MAIN BOARD	
Design: DL	04-MAR-04	Model: M19	
Check:		Board: 5367-166	
Approved: <i>[Signature]</i>	31-Mar-04	Sheet: 1 of 4	Series
11:08:49	31-Mar-2004	Rev: 4.0	Sheet
367x166a.sch		367	166

VK

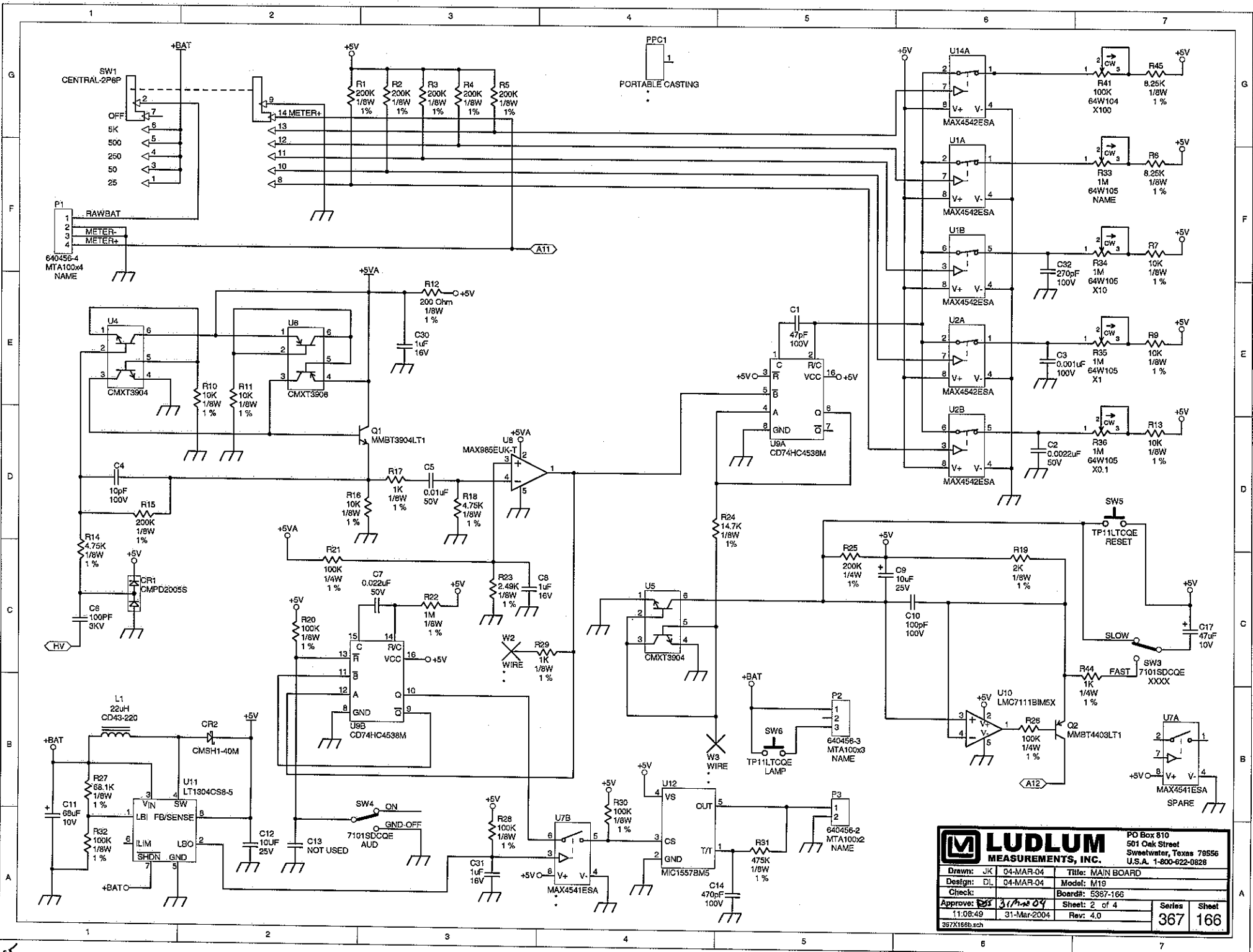

**LUDLUM MEASUREMENTS, INC.**  
 PO Box 810  
 501 Oak Street  
 Sweetwater, Texas 78556  
 U.S.A. 1-800-622-0828

Drawn: JK	04-MAR-04	Title: MAIN BOARD
Design: DL	04-MAR-04	Model: M19
Check:		Board#: 5387-168
Approve: <i>JK</i>	31-Mar-04	Sheet: 2 of 4
11:08:49	31-Mar-2004	Rev: 4.0
387X168b.sch		367 166

YK

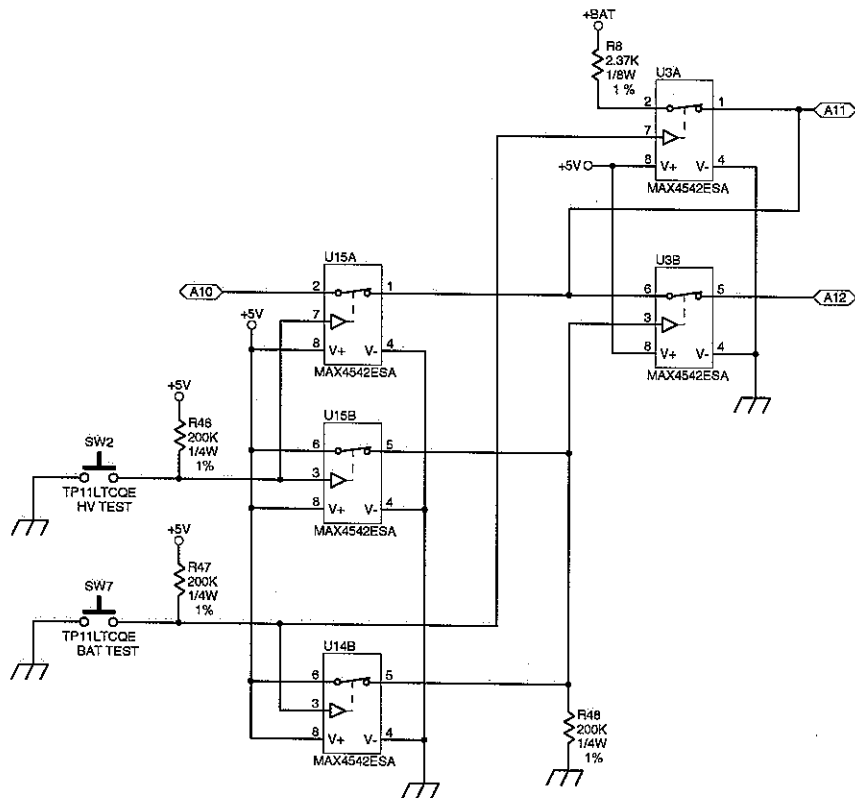

**LUDLUM**  
MEASUREMENTS, INC.

PO Box 810  
501 Oak Street  
Sweetwater, Texas 79556  
U.S.A. 1-800-622-0828

Drawn: JK	04-MAR-04	Title: MAIN BOARD
Design: DL	04-MAR-04	Model: M19
Check:		Board#: 5367-166
Approve: <i>[Signature]</i>	31-Mar-04	Sheet: 3 of 4
11:08:50	31-Mar-2004	Rev: 4.0
387X166c.sch		Series
		Sheet
		367 166

VF

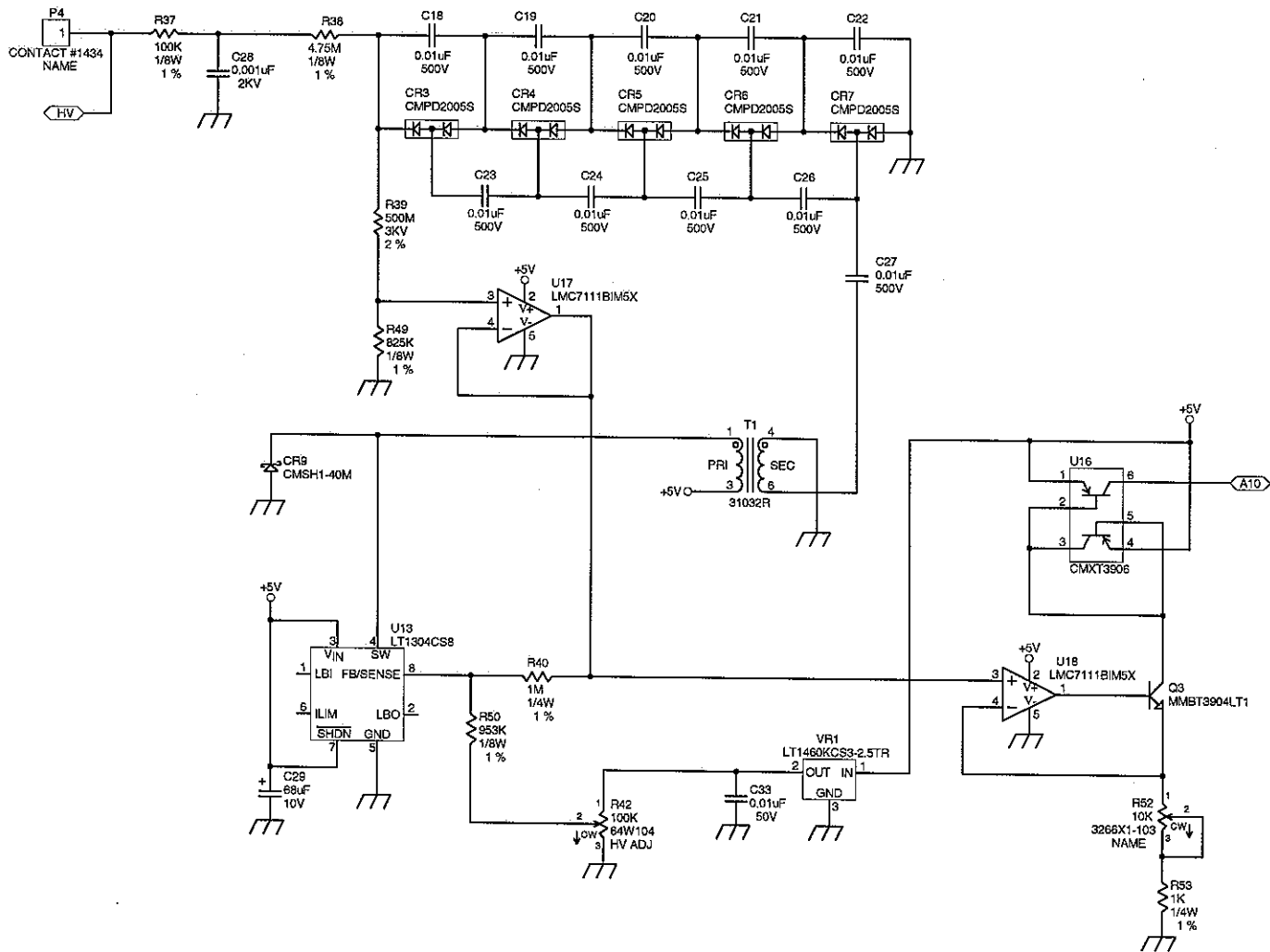

**LUDLUM MEASUREMENTS, INC.**  
 PO Box 810  
 501 Oak Street  
 Sweetwater, Texas 79556  
 U.S.A. 1-800-622-0828

Drawn: JK	04-MAR-04	Title: MAIN BOARD
Design: DL	04-MAR-04	Model: M18
Check:		Board#: 5367-168
Approve: <i>JK</i>	31-Mar-04	Sheet: 4 of 4
11:08:51	31-Mar-2004	Rev: 4.0
367X168d.sch		Series: 367
		Sheet: 166

JK



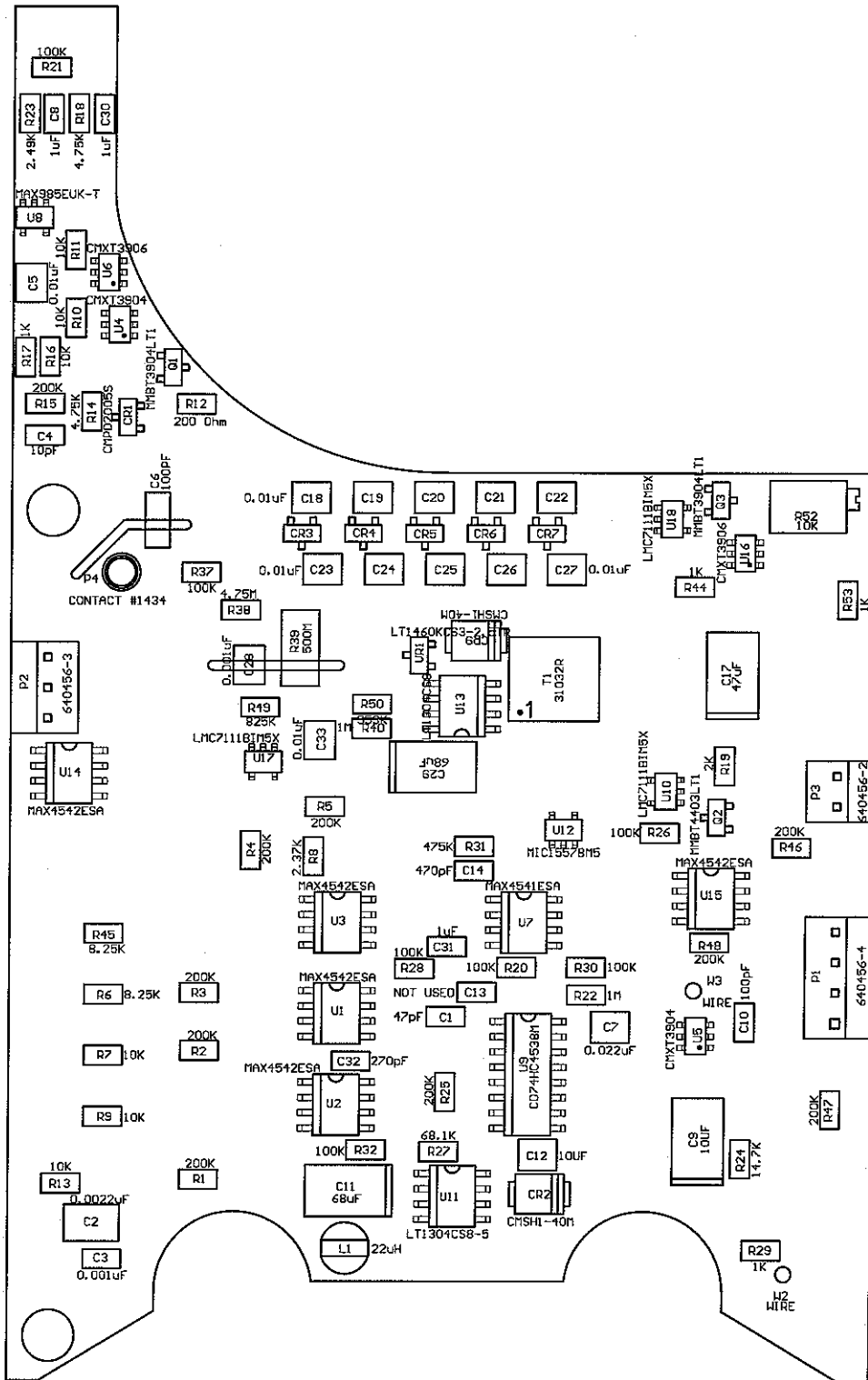

Drawn:	JK	04-MAR-04	Title: MAIN BOARD	
Design:	DL	04-MAR-04		
Check:	DL	06-MAR-04	Model: M19	
Approve:			Board#: 5367-166	
Layer:			Rev: 4.0	Series
	14:46:39	6-Apr-2004	SCALE: 1.75	Sheet
			367	167

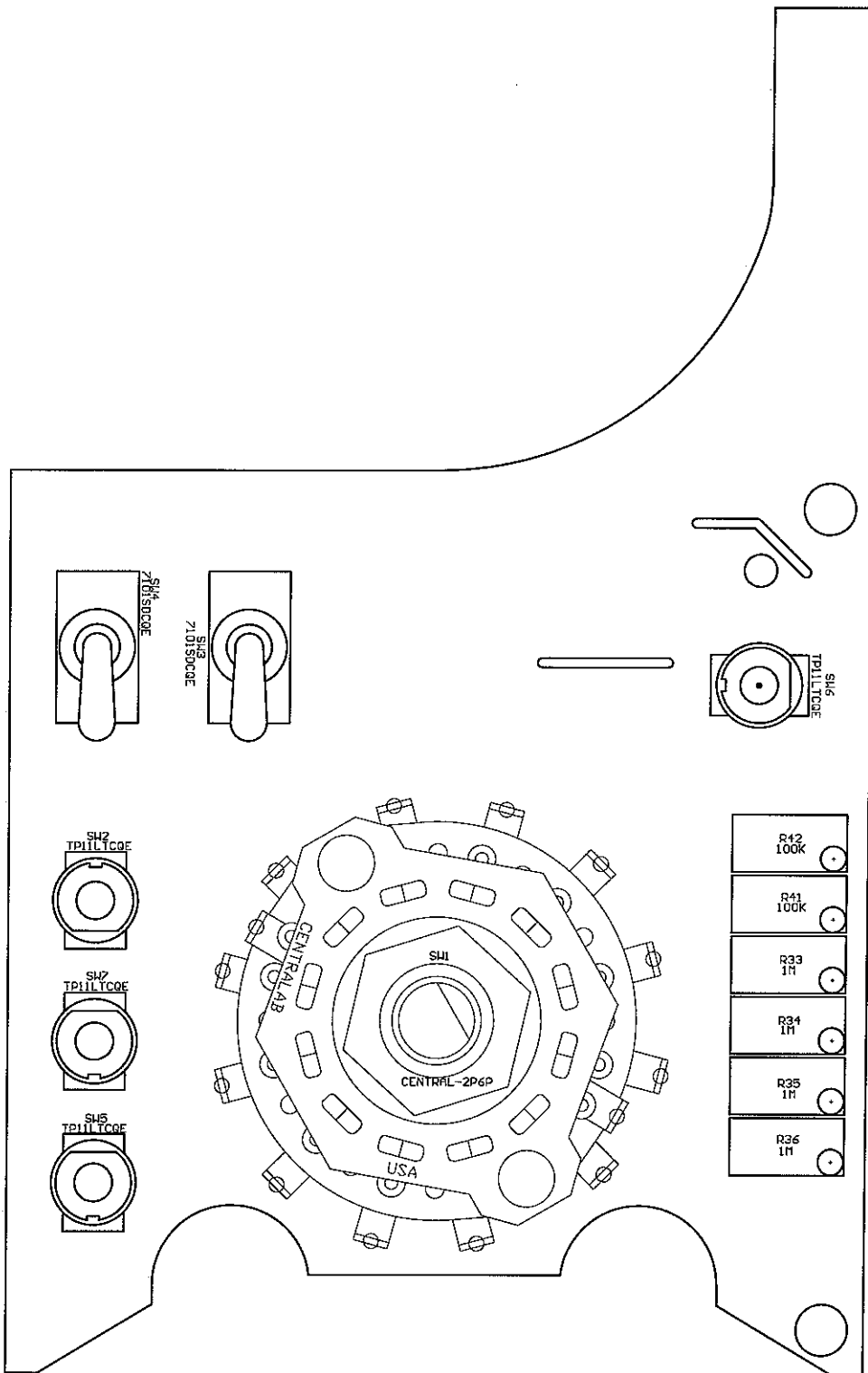

Drawn:	JK	04-MAR-04	Title: MAIN BOARD		
Design:	DL	04-MAR-04			
Check:	DL	06-MAR-04	Model: M19		
Approve:			Board#: 5367-166		
Layer:			Rev: 4.0	Series	Sheet
	14:46:40 6-Apr-2004		SCALE: 1.75	367	167

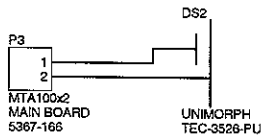
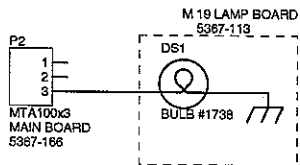
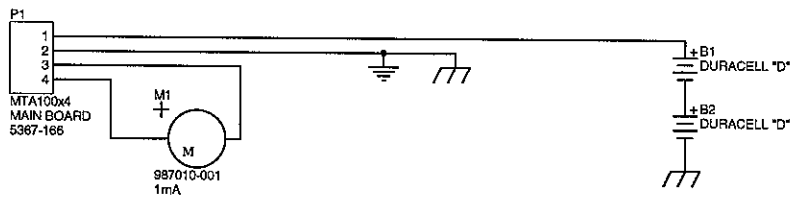

<b>LUDLUM</b> MEASUREMENTS, INC.		PO Box 810 501 Oak Street Sweetwater, Texas 79556 U.S.A. 1-800-622-0826	
Drawn: MEB	02-APR-04	Title: WIRING DIAGRAM	
Design: DL	02-APR-04	Model: 19	
Approve: <i>[Signature]</i>		Board: 367-174	
10.28.34	7-Apr-2004	Sheet: 1 of 1	Series Sheet
367x174		367 174	

### Energy Response for Ludlum Model 19

