

**LUDLUM ION CHAMBER
MODEL 9-4 USERS MANUAL**

May 2020

**Serial Number 265751 and Succeeding
Serial Numbers**

**LUDLUM ION CHAMBER
MODEL 9-4 USERS MANUAL**

May 2020

**Serial Number 265751 and Succeeding
Serial Numbers**



LUDLUM MEASUREMENTS, INC
501 OAK STREET, P.O. BOX 810
SWEETWATER, TEXAS 79556
325-235-5494, FAX: 325-235-4672

STATEMENT OF WARRANTY

Ludlum Measurements, Inc. warrants the products covered in this manual to be free of defects due to workmanship, material, and design for a period of twelve months from the date of delivery. The calibration of a product is warranted to be within its specified accuracy limits at the time of shipment. In the event of instrument failure, notify Ludlum Measurements to determine if repair, recalibration, or replacement is required.

This warranty excludes the replacement of photomultiplier tubes, G-M and proportional tubes, and scintillation crystals which are broken due to excessive physical abuse or used for purposes other than intended.

There are no warranties, express or implied, including without limitation any implied warranty of merchantability or fitness, which extend beyond the description of the face there of. If the product does not perform as warranted herein, purchaser's sole remedy shall be repair or replacement, at the option of Ludlum Measurements. In no event will Ludlum Measurements be liable for damages, lost revenue, lost wages, or any other incidental or consequential damages, arising from the purchase, use, or inability to use product.

RETURN OF GOODS TO MANUFACTURER

If equipment needs to be returned to Ludlum Measurements, Inc. for repair or calibration, please send to the address below. All shipments should include documentation containing return shipping address, customer name, telephone number, description of service requested, and all other necessary information. Your cooperation will expedite the return of your equipment.

**LUDLUM MEASUREMENTS, INC.
ATTN: REPAIR DEPARTMENT
501 OAK STREET
SWEETWATER, TX 79556**

**800-622-0828 325-235-5494
FAX 325-235-4672**

REVISION HISTORY

REV	DESCRIPTION	DATE	BY
1	VALID	12/15/2009	DDW

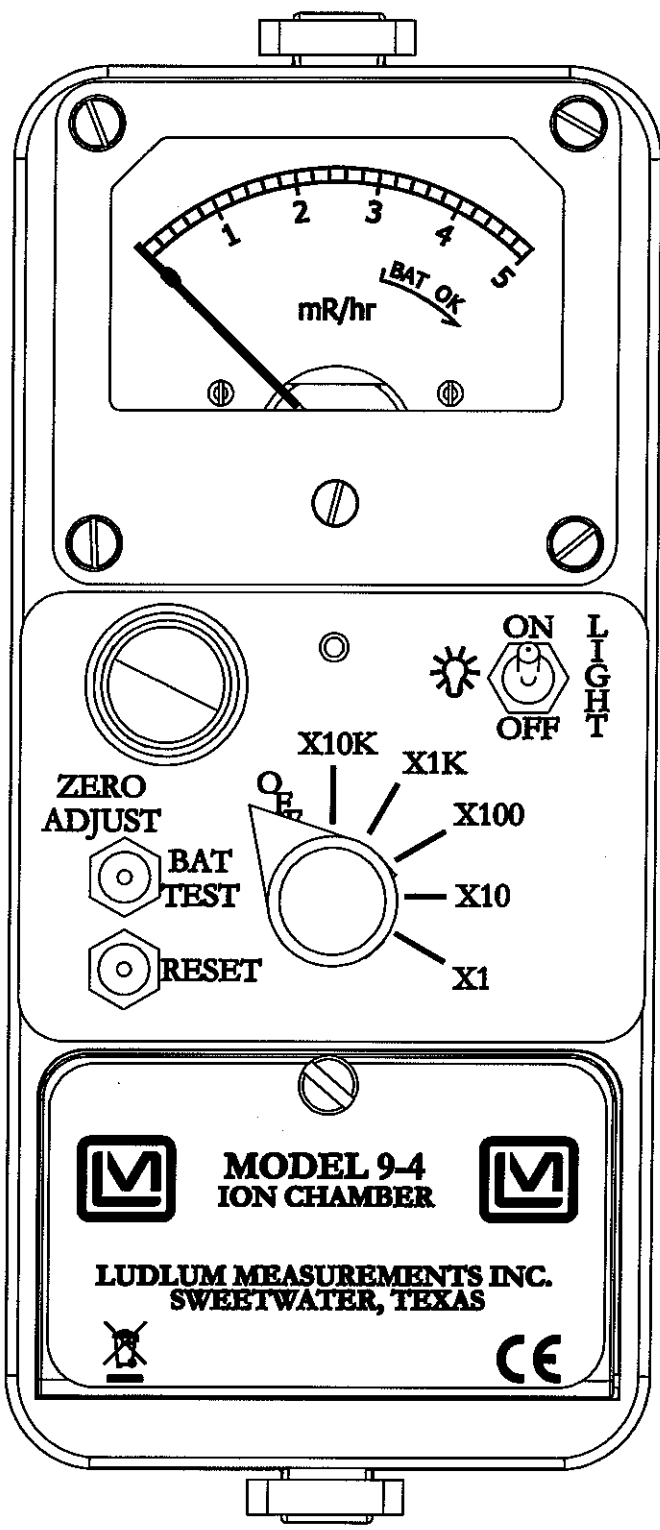

DWN	DATE	CHK	DATE	APP	DATE
DDW	12/15/09			DDW	4-30-10
DWG NUM: 4293-646.iam				SCALE: 1:1	
TITLE M 9-4					
LUDLUM MEASUREMENTS, INC. 501 OAK STREET SWEETWATER, TEXAS 75556			SERIES	SHEET	
			293	646	

Safety Precautions

In the interest of safety, this manual contains many notes, cautions, and warnings that the user should follow to protect both the user and the instrument from harm.

⚠ WARNING

Warning – The operator or responsible body is warned that failure to follow the specified operating, handling, or maintenance procedures may result in death, serious injury, or a long-term health hazard.

CAUTION

Caution - The operator or responsible body is cautioned that the protection provided by the equipment may be impaired if the equipment is used or handled in a manner not specified by Ludlum Measurements, Inc.

NOTE

Note – The operator or responsible body should give special attention to the information provided, as failure to do so may result in damage to the instrument or instrument failure.

GENERAL SAFETY PRECAUTIONS

The following general safety precautions apply to the operator of the instrument during all phases of operation. These precautions should be followed or else the instrument may no longer provide the necessary protection for which the instrument was intended.

DO NOT REMOVE CHASSIS FROM CAN WITH BATTERIES INSTALLED

Normal operation of the instrument should always be performed with the instrument chassis attached to a can. The operator is strongly cautioned to take the following precautions to avoid contact with internal hazardous live parts should it be determined that the chassis needs to be separated from the can:

1. Turn the instrument power off and remove the batteries.
2. Allow the instrument to sit for one minute before accessing internal components.

DO NOT SUBMERGE IN WATER

The instrument meets the standards as specified by ANSI N42.17C for moisture exposure; however, the instrument is not waterproof and should never be submersed in water.

WARNINGS APPLICABLE TO HAZARDOUS MATERIALS

Visual images are used in this manual to convey the possible hazard associated with the operation, handling, or maintenance of the instrument. The following definitions are provided to describe these hazards; however, Ludlum Measurements cannot make any guarantees to the extent of the hazard posed.



CHEMICAL – this is an indication that handling the material may cause burns or irritation to the skin.



ELECTRICAL SHOCK – unless the necessary precautions are taken, this is an indication that physical contact with the internal components of the instrument may result in electrical shock.



HOT AREA – this is an indication that the component or components may be hot resulting in burns to the skin.



POISON – this is an indication that the contents may be hazardous to your health if consumed.

INSTRUMENT MARKINGS

The Model 9-4 Ion Chamber is marked with the following symbols:



Crossed-out wheellie bin – this symbol notifies the consumer that the product is not to be mixed with unsorted municipal waste when discarding; each material must be separated. The symbol is placed on the battery compartment lid.



The “CE” mark is used to identify this instrument as being acceptable for use within the European Union.

TABLE OF CONTENTS

INTRODUCTION	1
IDENTIFICATION OF CONTROLS AND FUNCTIONS	2
GETTING STARTED	3
UNPACKING AND REPACKING	3
INSTRUMENT CONFIGURATION	3
BATTERY INSTALLATION	4
BATTERY TEST	5
OPERATIONAL CHECK	5
TECHNICAL THEORY OF OPERATION	7
CHAMBER	7
CHAMBER WINDOW	7
ELECTROMETER	7
RANGE CHANGE	8
RESET	8
OFFSET ADJUSTMENT	8
ZERO ADJUST	8
RANGE CALIBRATION	9
RANGE CHANGING	9
POWER SUPPLIES	10
CLEANING AND MAINTENANCE	11
PRECAUTIONS	11
MAINTENANCE	11
<i>Recalibration</i>	11
<i>Storage</i>	12
<i>Desiccant</i>	12
SPECIFICATIONS	14
RECYCLING	17
PARTS LIST	18
MAIN CIRCUIT BOARD, DRAWING 293 x 711	19
ELECTROMETER BOARD, DRAWING 293 x 670	22
DRAWINGS	23

TABLE OF FIGURES

Figure 1 - Battery Installation and Removal	4
Figure 2 - Battery Door Internal Markings	5
Figure 3 - Main Board Layout (Front)	Back of manual
Figure 4 - Main Board Layout (Back)	Back of manual
Figure 5 - Main Board Schematic (Page 1)	Back of manual
Figure 6 - Main Board Schematic (Page 2)	Back of manual
Figure 7 - Main Board Schematic (Page 3)	Back of manual
Figure 8 - Main Board Schematic (Page 4)	Back of manual
Figure 9 - Electrometer Board Layout (Front)	Back of manual
Figure 10 - Electrometer Board Schematic (Page 1)	Back of manual

Section**1**

Introduction

The Ludlum Model 9-4 is a five-range ion chamber instrument for measuring beta-gamma radiation up to 50 R/hr. The chamber wall, including the instrument case, is 1000 mg/cm². A 1000 mg/cm² retractable beta shield allows beta measurement with a 7 mg/cm² window.

The six-position selector switch selects **OFF**, **×10K**, **×1K**, **×100**, **×10**, and **×1** multipliers. The standard meter face has a dial from 0 to 5 mR/hr. Other features include a **LIGHT** toggle switch to activate the white LED display light, a **RESET** pushbutton, and a **ZERO ADJUST** knob. All calibration controls are done digitally using a special calibration kit (part number: 4293-676) available from Ludlum Measurements. This kit includes a special instrument can, pressure calibration kit, all necessary cables, and control software.

The Model 9-4 calibration kit allows the ability to calibrate for temperature and pressure. Temperature and pressure compensation thus allows the instrument to measure within 20% of the true value even when the temperature is varied from -20 to 50 °C (-4 to 122 °F), and within 15%, as the pressure is varied from 70 kPa to 106 kPa.

The unit is powered by two “D” cell batteries. A fresh set of alkaline batteries should last more than 400 hours. An internal shunt may be positioned so that the detector wall voltage is maintained even when the unit is **OFF**. Doing so reduces the normal fifteen-minute, cold-start delay.

Section

2

Identification of Controls and Functions

Range Selector Switch: This is a six-position switch marked **OFF**, **×10K**, **×1K**, **×100**, **×10**, and **×1**. Turning the range selector switch from **OFF** to one of the range multiplier positions (**×10K**, **×1K**, **×100**, **×10**, and **×1**) provides the operator with an overall range of 0 to 50,000 mR/hr. Multiply the scale reading by the multiplier to determine the actual scale reading.

BAT TEST: Press this switch to check the battery. The meter should read within the **BAT TEST** scale on the meter. The range switch may be in any position except **OFF** for the battery test.

LIGHT ON-OFF Toggle Switch: In the **ON** position this switch energizes the white LED display lights located in the meter compartment.

ZERO ADJUST: This is a full one-turn control that allows for compensation of electrometer drift. Press and hold the **RESET** button for five seconds, then adjust for a zero reading.

RESET Button: The **RESET** circuit grounds the chamber and opens the chamber connection to the electrometer. This action causes a hard upscale transient on the **×1** and **×10** scales. Hold the **RESET** down for five seconds to allow the transient to decay. When the **RESET** switch is released, the chamber is reconnected to the electrometer, and a hard downscale transient will occur. Allow five more seconds for recovery.

Beta Shield (on bottom): This retractable shield allows exposure to beta radiation with a window thickness of 7 mg/cm². With the slide closed, the window is 1000 mg/cm². Depress the button on the side of the slide assembly to release the slide. Release the button to hold the slide open or closed.

Section**3**

Getting Started

Unpacking and Repacking

Remove the calibration certificate and place it in a secure location. Remove the instrument and all accessories and ensure that all items on the packing list are in the carton.

To return an instrument for calibration or repair, provide sufficient packing material to prevent damage during shipment and affix appropriate warning labels to promote careful handling.

Every returned instrument must be accompanied by an Instrument Return Form, which can be downloaded from the Ludlum website at www.ludlums.com. Find the form by clicking the “Support” tab and selecting “Repair and Calibration” from the drop-down menu. Then choose the appropriate Repair and Calibration division where you will find a link to the form.

Instrument Configuration

The Model 9-4 has two options for chamber wall voltage. An internal jumper may be selected to maintain voltage on the chamber wall with the instrument turned off. This option allows a faster, three-minute settling time when the instrument is frequently used. If the instrument is infrequently used, it is recommended that this option not be used because of battery drain.

NOTE

The instrument is shipped with the chamber wall voltage maintained when the instrument is turned off.

With the continuous wall voltage on and instrument off, battery life is approximately six months. Without this option, the battery drain is zero with the instrument **OFF**; however, a settling time of 15 minutes is required for the $\times 1$ scale to settle within 0.1 mR/hr.

Battery Installation

Ensure the Model 9-4 range selector switch is in the **OFF** position. Open the battery lid by pushing down and turning the quarter-turn thumbscrew counterclockwise a quarter of a turn. Install two “D” size batteries in the compartment.

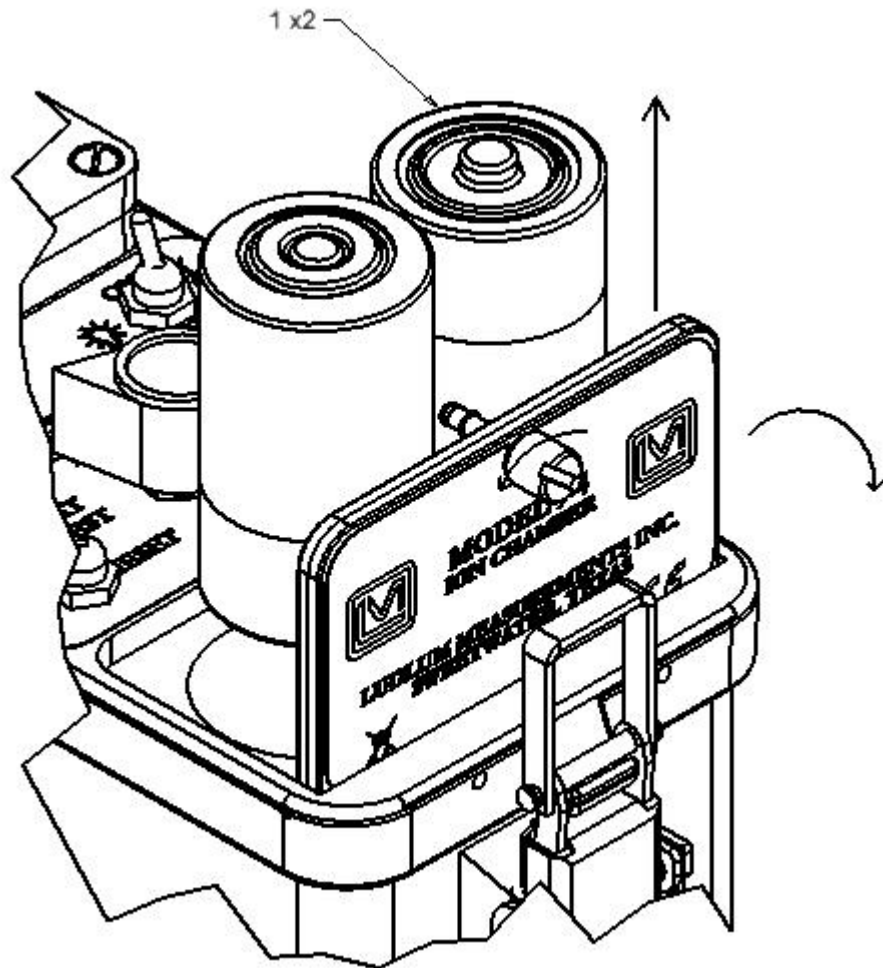

Figure 1 - Battery Installation and Removal

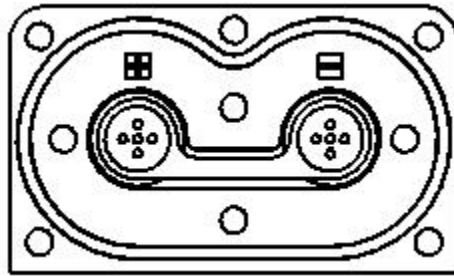

Figure 2 - Battery Door Internal Markings

Note the (+) and (-) marks inside the battery holder (see Figure 2 - Battery Door Internal Markings). Match the battery polarity to these marks. Insert both batteries to match these marks. Close the battery box lid, then push down and turn the quarter-turn thumb screw clockwise a quarter of a turn.

NOTE

The center post of a battery is positive. The batteries are placed in the battery compartment in opposite directions.

Battery Test

The batteries should be checked each time the instrument is turned on. This is accomplished simply by pressing the **BAT TEST** button. Ensure that the meter needle deflects to the battery test portion of the meter scale. If the meter does not respond, check to see if the batteries have been correctly installed. Replace the batteries if necessary.

Operational Check

To assure proper operation of the instrument between calibrations and periods of non-use, the following instrument operational check should be performed prior to use. A reference reading with a check source should be obtained at the time of initial calibration or as soon as possible for use in confirming proper instrument operation. In each case, ensure a proper reading on each scale. If the instrument fails to read within 20% of a proper reading, it should be sent to a calibration facility for recalibration.

Turn the instrument range switch to the $\times 1$ position.

NOTE

As the selector switch moves from the $\times 100$ to $\times 10$ a meter transient will occur. This transient is caused by an internal range relay and is normal.

Allow time for the $\times 1$ scale to stabilize.

Press and hold the **RESET** button. Adjust the **ZERO ADJUST** knob until a meter reading of zero is obtained. Release the **RESET** button.

NOTE

The **RESET** circuit grounds the chamber and opens the chamber connection to the electrometer. This would normally cause a transient on the $\times 1$ or $\times 10$ scale. The meter needle will, on these two ranges, display a “countdown” from five to zero when the **RESET** is pressed, and also when it is released. On these two lower ranges the user should hold the **RESET** down for five seconds to allow the transient to decay.

Expose the instrument to a check source. Observe that the meter reading increases as the check source gets closer to the instrument.

NOTE

The depressions on the side of the instrument housing indicate the center of the chamber.

Open the beta shield and expose the check source to the center of the chamber window. The instrument reading should be within 20% of the check source reference after settling time.

CAUTION

Damage to the metallized polyester window on the back side of the instrument may result when the slide is open if careful instrument handling is not practiced. The window is fragile and may be punctured quite easily.

Section**4**

Technical Theory of Operation

Chamber

The chamber housing is constructed from acrylic and is coated inside and outside with carbon. The internal wall is maintained at approximately -90 volts. The external wall is at guard potential (approximately 1.5 volts).

The electrode is connected to the electrometer input and is maintained at guard potential by the electrometer.

Chamber Window

The chamber window consists of three parts. The beta shield is 1000 mg/cm² phenolic. One layer of 3.5 mg/cm² aluminized metallized polyester is glued to the bottom of the can. One layer of 3.5 mg/cm² aluminized metallized polyester covers the ion chamber, resulting in a window thickness of 7 mg/cm² with the beta slide open and a 1000 mg/cm² window with the beta slide closed.

Electrometer

The electrometer consists of U1, R2, and supporting components. On the $\times 1$ scale, RL1 and RL2 are open. With conduction in the chamber to the negative wall, pin 8 of U1 goes slightly negative causing pin 4 of U1 to go positive, drawing current through R2, holding pin 8 of U1 near the guard voltage (+1.5 volts).

With the chamber exposed to a 5 mR/hr field, the chamber current will be approximately 70 fA (70×10^{-15} amps) and electrometer output voltage will be 35 mV (0.035 V) relative to the guard voltage. At 50 mR/hr on the $\times 10$ range, the output voltage will be 350 mV (0.35 V) relative to the guard voltage.

Range Change

When the instrument is switched to the $\times 100$, $\times 1K$, or $\times 10K$ range, RL1 is closed, reducing the feedback resistance to approximately 4.2×10^9 ohms. At 500 mR/hr on the $\times 100$ range, the chamber current will be approximately 7 pA (7×10^{-12} amps) and the voltage out at pin 6 of U1 will be approximately 30 mV (0.03 V). Full-scale voltage outputs relative to the guard voltage for the $\times 1K$ and $\times 10K$ are 300 mV (0.3 V) and 3 V respectively.

Reset

Relay RL2 allows the chamber to be shorted to guard and the electrometer to be isolated for input bias current compensation.

Offset Adjustment

The electrometer op amp will have some offset voltage. Internal calibration control R111 will provide an offset voltage that can be adjusted to null out the electrometer offset voltage. Place instrument in a field less than 0.1 mR/hr, then select the **$\times 100$** scale and adjust R111 for zero meter reading.

Zero Adjust

The primary function of the zero adjust is to control input bias current in the electrometer. With the **RESET** (SW1) closed, the reset relay (RL2) opens the electrometer input and shorts the chamber output to guard. With the **RESET** held closed, input bias current is adjusted with the zero control for a zero meter dial reading.

NOTE

Allow a five-second recovery period for the meter to settle before and after using the **RESET** button on the **$\times 1$** and **$\times 10$** scales.

Range Calibration

Full-scale voltage for the electrometer output, pin 4 of U1 (electrometer board 5293-711) is approximately +0.03 volts for the $\times 1$ range; 0.3 volts for the $\times 10$ range; +0.03 volts for the $\times 100$; and +0.3 volts for the $\times 1K$ range. The $\times 10K$ range will be somewhat lower than +3 volts due to nonlinear collection.

On the $\times 1$ scale, the electrometer voltage is coupled through the analog switch U102A to a series of op amps. U101 provides gain. U100 provides gain and reduces the output and reference from guard voltage to 0.2 volts. Voltage output at pin 1, U100 is approximately 2 volts at full scale. Higher scales follow the same scheme through the analog switches selected by the range switch.

The output voltage of U100 is connected to microprocessor U110 which allows calibration, temperature correction, and altitude compensation.

The signal reference voltage is 0.2 volts at the output of DA converter U112, allowing a below-zero meter reading when adjusting the zero control.

Range Changing

The microprocessor U110 detects the selected range and then selects the appropriate analog switch (U102A, U102B, or U103A) for the signal.

A calibration constant is then provided by the microprocessor for each range.

In the special case of $\times 10K$ scale, the microprocessor also provides a linearity correction.

Each range may be calibrated by a calibration equipment kit when connected to P102.

Power Supplies

Six voltages are provided for instrument operation.

U108 and associated components generate -90 volts for chamber wall voltage. The supply will run continually with the instrument off if the jumper is placed between pins 1 and 2 of JP100. If the operator chooses to have wall voltage off with the instrument switched off, then the jumper should be moved to pins 2 and 3 of JP100.

U105 and associated components generate +5 volts for the main board circuits.

U106 provides regulated +2.5 volt reference.

VR100 provides +4.85 volts for the electrometer.

U107 and associated components provides 1.5 volt guard voltage for the electrometer.

U104 provides meter reference of 0.2 volts.

Section**5**

Cleaning and Maintenance

Precautions

Instrument maintenance consists of keeping the instrument clean and periodically checking the batteries, desiccants, and calibration. The Model 9-4 (excluding chamber window) may be cleaned externally with a damp cloth, using only water as the wetting agent. Do not immerse the instrument in any liquid. Observe the following precautions when cleaning or performing maintenance on the instrument:

1. Turn the instrument **OFF** and remove the batteries.
2. Allow the instrument to sit for one minute before cleaning the exterior or accessing any internal components for maintenance.

WARNING

Accessing internal components for maintenance increases the risk of electrical shock if these steps are not followed.

Maintenance

RECALIBRATION

Recalibration should be accomplished after maintenance or adjustments have been performed on the instrument. Recalibration is not normally required following instrument cleaning, desiccant servicing, or battery replacement.

NOTE

Ludlum Measurements, Inc. recommends recalibration at intervals no greater than one year. Check the appropriate regulations to determine required recalibration intervals.

Ludlum Measurements offers a full-service repair and calibration department. We not only repair and calibrate our own instruments, but also most other manufacturers' instruments. Calibration procedures are available upon request for customers who choose to calibrate their own instruments.

STORAGE

The batteries may be removed any time the instrument is placed into storage. Battery leakage may cause corrosion on the battery contacts, which must be scraped off and/or washed using a paste solution made from baking soda and water.

CAUTION

Although this instrument will operate at very high ambient temperatures, battery seal failure may occur at temperatures as low as 37 °C (100 °F). Should battery seal failure occur, it may result in corrosion on the battery contacts.

DESICCANT

Remove the instrument can and observe the translucent plastic desiccant box. If the desiccant is blue, close the can and use the instrument. If the desiccant is pink, replace with a fresh box. The restraining strap may be loosened by pressing the center tab toward the strap.

WARNING



The silica used in the desiccant box may cause irritation to the skin if handled directly. Please take the necessary precautions to avoid long-term physical contact with the silica. Should handling of the product be required, avoid rubbing your eyes or placing your hands in or around your mouth as the silica may also cause an irritation of the digestive tract. Wash with mild soap and water after handling.

The pink (wet) desiccant may be recycled by placing it in an oven at 55 °C (131 °F) for two hours, or in a microwave on the HI setting for 10 seconds. If water vapor is apparent, wipe off the water and heat for another 10 seconds. Repeat until the box and desiccant appear dry.

Repeat until the box and desiccant appear dry. When fully dried out, the desiccant will be blue in color.



The desiccant box may be **HOT** when removed from the microwave or oven! Please use caution so as to avoid burning your skin.

If the instrument is stored in an area with high humidity, rapid changes in temperature should be avoided. A storage cabinet with a light bulb inside is one means of keeping the instrument in a slightly warmer-than-ambient temperature environment in order to prevent problems from rapid changes in temperature and humidity.

Section

6

Specifications

Linearity: reading within 10% of true value

Range: 0-500 mSv/h (0-50,000 mR/hr)

Chamber:

Chamber Wall Construction: carbon-coated acrylic

Chamber Volume: 220 cm³ (13.4 in³)

Window: 7 mg/cm² metallized polyester

Window Area: 40 cm² (6.2 in²)

Beta Shield: retractable 1000 mg/cm² phenolic slide

Beta Factor: with the instrument exposed to a depleted uranium slab of 234 mrad/hr:

Reading with slide open: 50 mR/hr

Reading with slide closed: 1.2 mR/hr

Thus, Beta Factor = 234 divided by (50 minus 1.2) = 4.8

Energy Response: within 20% of true value from 40 keV to 2 MeV

Magnetic Field Exposure: per ANSI 42-17A, magnetic fields of 800 A/m cause less than a 15% deviation in instrument response

Multipliers: ×1, ×10, ×100, ×1K, and ×10K selected by a front-panel range selector switch. Transient meter movement will occur when switching between the ×10 and ×100 ranges; allow three seconds for the meter to stabilize upscale, 15 seconds to stabilize downscale.

Noise: Approximately every three minutes an up-scale “kick” may be noted on the ×1 scale. This is due to normal cosmic background radiation.

Response: approximately five seconds for 90% of final meter deflection on the $\times 1$ and $\times 10$ scales, and three seconds on the $\times 100$, $\times 1K$, and $\times 10K$ scales

Warm-up Time: For the $\times 1$ scale and if the wall voltage option is on with the instrument off, the scale will settle within 0.1 mR/hr within three minutes. If the wall voltage option is off, allow 15 minutes for the $\times 1$ scale to settle within 0.1 mR/hr.

Reset: The **RESET** circuit grounds the chamber and opens the chamber connection to the electrometer. This would normally cause a transient on the $\times 1$ or $\times 10$ scale. The meter needle will, on these two ranges, display a “countdown” from five to zero when the **RESET** is pressed, and also when it is released. On these two lower ranges the user should hold the **RESET** down for five seconds to allow the transient to decay.

Zero Adjust: a control allowing limited background subtract and also used to compensate electrometer drift

Battery Check: Batteries are good if the meter needle is above the **BAT OK** mark when the **BAT TEST** pushbutton is pressed. At 2.1 Vdc the meter needle will drop to the edge of the **BAT OK** area when the **BAT TEST** pushbutton is pressed.

Battery Dependence: Instrument calibration change is less than 5% within battery check limits on the meter.

Battery Life: approximately 400 hours of normal use without display light; battery life with instrument off but with wall voltage being maintained is approximately six months

Construction: cast and drawn aluminum with beige powder coating and subsurface printed Lexan labels

Dimensions: 23.4 x 8.9 x 21.6 cm (9.2 x 3.5 x 8.5 in.) (H x W x L), including instrument handle

Humidity Range: 40% to 90% relative humidity maintains reading within 15% of standard conditions (40% RH at 22 °C reading)

Meter: 6.4 cm (2.5 in.) arc, mA, pivot-and-jewel suspension

Meter Dial: **BAT TEST**, 0-5 mR/hr linear for $\times 1$ through $\times 10K$ ranges

Pollution: Degree 3 (as defined by IEC 664) (Due to condensation, conductive pollution or dry nonconductive pollution that becomes conductive occurs. This is found in industrial environments or construction sites, considered harsh environments.)

Power: two “D” cell batteries housed in a sealed externally accessible compartment

Temperature Range: -20 to 50 °C (-4 to 122 °F); temperature compensation maintains calibration within 20% of 22 °C (72 °F) reading over the entire temperature range

Weight: 1.9 kg (4.2 lb), including batteries

Section

7

Recycling

Ludlum Measurements, Inc. supports the recycling of the electronics products it produces for the purpose of protecting the environment and to comply with all regional, national, and international agencies that promote economically and environmentally sustainable recycling systems. To this end, Ludlum Measurements, Inc. strives to supply the consumer of its goods with information regarding reuse and recycling of the many different types of materials used in its products. With many different agencies – public and private – involved in this pursuit, it becomes evident that a myriad of methods can be used in the process of recycling. Therefore, Ludlum Measurements, Inc. does not suggest one particular method over another, but simply desires to inform its consumers of the range of recyclable materials present in its products, so that the user will have flexibility in following all local and federal laws.

The following types of recyclable materials are present in Ludlum Measurements, Inc. electronic products, and should be recycled separately. The list is not all-inclusive, nor does it suggest that all materials are present in each piece of equipment:

Batteries	Glass	Aluminum and Stainless Steel
Circuit Boards	Plastics	Liquid Crystal Display (LCD)

Ludlum Measurements, Inc. products, which have been placed on the market after August 13, 2005, have been labeled with a symbol recognized internationally as the “crossed-out wheelie bin.” This symbol notifies the consumer that the product is not to be mixed with unsorted municipal waste when discarding; each material must be separated. The symbol will be placed near the AC receptacle, except for portable equipment where it will be placed on the battery lid.

The **symbol** appears as such:



Section 8

Parts List

The following parts are included with the Model 9-4 Five-Range Ion Chamber (Part Number 48-3739)

	Reference	Description	Part Number
Model 9-4 Ion Chamber	Figures 1 and 4	Model 9-4 Ion Chamber W/O Accessories	4293-646
Batteries	Figure 2-1 (x2)	Duracell D-Cell Alkaline Batteries	21-9313
Handle		Handle Portable (Grip)	7363-139
Screws		6-32 x 3/8 Flat Button Head Stainless Steel Screws	17-8519
Washers		#6 Stainless Steel Internal Tooth Lock Washer	20-9009
Shielding		Model 9-4 Chamber Top Co-Netic Shield	7536-223
		Model 9-4 Chamber Top Netic Shield	7536-224
Manual		Model 9-4 User's Manual	Model 9-4
Calibration Certificate		Certificate of Calibration (Valid for 1 Year)	FORM C22A

The Model 9-4 Five-Range Ion Chamber w/Case (Part Number 48-3701) includes all the parts included with the 48-3739 as well as the following:

Storm Case	Storm CS-DSI-iM2300	2311063 Medium Black	
Main Circuit Board, Drawing 293 x 711	BOARD Completely Assembled Main Circuit Board	5293-711	
	Reference	Description	Part Number
CAPACITORS	C100	1uF, 35V	04-5656
	C101	0.01uF, 200V	04-5747
	C102,C103	0.47uF, 50V	04-5760
	C104	10uF, 10V-DT	04-5766
	C105	1uF, 35V	04-5656
	C106	0.01uF, 200V	04-5725
	C107	1uF, 35V	04-5656
	C108	0.001uF, 100V	04-5659
	C109	68uF, 10V	04-5654
	C110	0.1uF, 100V	04-5792
	C111	1uF, 50V	04-5708
	C112	0.001uF, 100V	04-5659
	C113- C116	0.01uF, 200V	04-5765
	C118- C119	0.01uF, 200V	04-5765
	C120	0.47uF, 100V	04-5776
	C121, C122	0.01uF, 200V	04-5765
	C123	68uF, 10V	04-5654
	C124, C125	0.1uF, 100V	04-5792
	C126	0.01uF, 200V	04-5725
	C127	0.1uF, 100V	04-5792
	C128	1uF, 16V	04-5701
	C129	0.01uF, 50V	04-5664
	C130	0.47uF, 100V	04-5760
	C131, C132	0.47uF, 100V	04-5776
	C133	0.1uF, 100V	04-5792
TRANSISTORS	Q100	SI2301BDS-TI	07-6486
	Q102	SI2301BDS-TI	07-6486
	Q103, Q104	2N7002LT1G	05-5840
INTEGRATED CIRCUITS	U100, U101	LMC7111BIM5X	06-6410
	U102, U103	MAX4542ESA	06-6453
	U104	LMC7111BIM5X	06-6410

	Reference	Description	Part Number
	U105	LT1304CS8-5	06-6434
	U106	LT1790BIS6-2.5	06-6691
	U107	LMC7111BIM5X	06-6410
	U108	LT1617ES5-1	06-6760
	U109	SM5420-030-A-P-T	2311127
	U110	PIC18LF2520-I/SO	06-6696
	U111	INA126UA	06-6726
	U112	MCP4822-E/SN	06-6722
	U113	MCP9800AOT-M/OTG	06-6687
	U114	MAX809JTRG	06-6423
	U115	LMC7111BIM5X	06-6410
DIODES	CR100	CMSH1-40M	07-6411
	CR101-CR103	CMPD2005S	07-6468
	CR104	MMBZ5270BL	07-6474
	CR105	CMPD2005S	07-6468
	CR106	CMPSH-3 TR	07-6489
	CR107	CMPD3003S	07-6515
RESISTORS	R100	100K, 250mW, 1%	12-7834
	R101	365K, 250mW, 1%	12-7049
	R102	61.9K, 250mW, 1%	12-7026
	R103	1M, 250mW, 1%	12-7844
	R104	22.1Ohm, 250mW, 1%	12-7055
	R105	100K, 250mW, 1%	12-7834
	R106	365K, 250mW, 1%	12-7049
	R107	15K, 250mW, 1%	12-7998
	R108	47.5K, 250mW, 1%	12-7872
	R109	27K, 250mW, 1%	12-7243
	R111	100K, 3266X1-104	09-6823
	R112	154K, 250mW, 1%	12-7197
	R113	221Ohm, 250mW, 1%	12-7017
	R114	249K, 250mW, 1%	12-7862
	R115	82.5K, 250mW, 1%	12-7849
	R116	1.5M, 250mW, 1%	12-7987
	R117	27K, 250mW, 1%	12-7243
	R118	82.5K, 250mW, 1%	12-7849
	R119	1M, 250mW, 1%	12-7844
	R121	182K, 250mW, 1%	12-7860
	R122	90.9K, 250mW, 1%	12-7224
	R124	61.9K, 250mW, 1%	12-7026
	R125	499K, 250mW, 1%	12-7037

	R126	10M, 250mW, 1%	12-7996
	R128	750K, 250mW, 1%	12-7882
	R130	10M, 250mW, 1%	12-7996
	R131	3.01M, 250mW, 1%	12-720
	R134	100K, 250mW, 1%	12-7834
	R135	221K, 250mW, 1%	12-7845
	R136	10K, 250mW, 1%	12-7839
	R137	1M, 250mW, 1%	12-7844
	R138	1K, 250mW, 1%	12-7832
	R139	1.96K, 250mW, 1%	12-7065
	R140	1K, 250mW, 1%	12-7832
	R141-R143	1M, 250mW, 1%	12-7844
	R144	1K, 250mW, 1%	12-7832
	R145	100Ohm, 250mW, 1%	12-7840
	R146-R149	1M, 250mW, 1%	12-7844
	R150	1K, 250mW, 1%	12-7832
	R151	221K, 250mW, 1%	12-7845
	R152, R153	1M, 250mW, 1%	12-7844
	R154	100Ohm, 250mW, 1%	12-7840
	R155	1M, 250mW, 1%	12-7844
	R156	100Ohm, 250mW, 1%	12-7840
	R157	1K, 250mW, 1%	12-7832
	R158	47.5K, 250mW, 1%	12-7872
	R159	100K, 3266X1-104	09-6823
	R160	124K, 250mW, 1%	12-7032
	R161	1MK, 250mW, 1%	12-7844
	R162	10K, 250mW, 1%	12-7839
	R163	301Ohm, 250mW, 1%	12-7863
CONNECTORS	P100	1-640456-0 MTA100×10	13-8066
	P101	640456-3 MTA100×3	13-8081
	P102	53014-0610MOLEX	13-8974
	P103	640456-5 MTA100×5	13-8057
	P104	640456-4 MTA100×4	13-8088
SWITCHES	SW100	3S1-SP9-B8-M2QE	7464-186
	SW101	D5G0206S-9802	08-6761
	SW102	3S1-SP9-B8-M2QE	7464-186
	SW103	A123S1CWCQ	08-6781
MISCELLANEOUS	JP100	5-146280-3	13-8571
	L100, L101	22uH	21-9808

**Electrometer Board,
Drawing 293 × 670**

	BOARD	Completely Assembled Electrometer Board	5293-442
CAPACITORS	C1	2pF, 200V	04-5726
INTEGRATED CIRCUIT	U1	IC-LMP7721MA	06-6728
DIODES	CR1-CR2	CMPSH-3	07-6489
RESISTORS	R1	1M, 1/4W, 1%	12-7844
	R2	500G, 330mW, 20%	12-7248
	R3	4.2G, 1W, 10%	12-8022
	R6	27K, 1/4W, 1%	12-7243
	R7	500G, 330mW, 20%	12-7248
	R8	1M, 1/4W, 1%	12-7844
	R9	27K, 1/4W, 1%	12-7243
RELAYS	RL1	Bobbin Assembly SPST-NC MDSR-7 Reed Assy.	4293-541 7293-532
	RL2	Bobbin Assembly SPDT MDRR-DT Reed Assy.	4293-538 7293-543
CONNECTORS	P1	1-640456-0 MTA100×10	13-8066
	P2	103186-1	13-847

Section**9****Drawings**

MAIN BOARD SCHEMATIC, Drawing 293 × 711 (4 Sheets)

MAIN BOARD LAYOUT 293 × 712A (2 Sheets)

ELECTROMETER BOARD, Drawing 293 × 670

ELECTROMETER BOARD LAYOUT 293 × 671

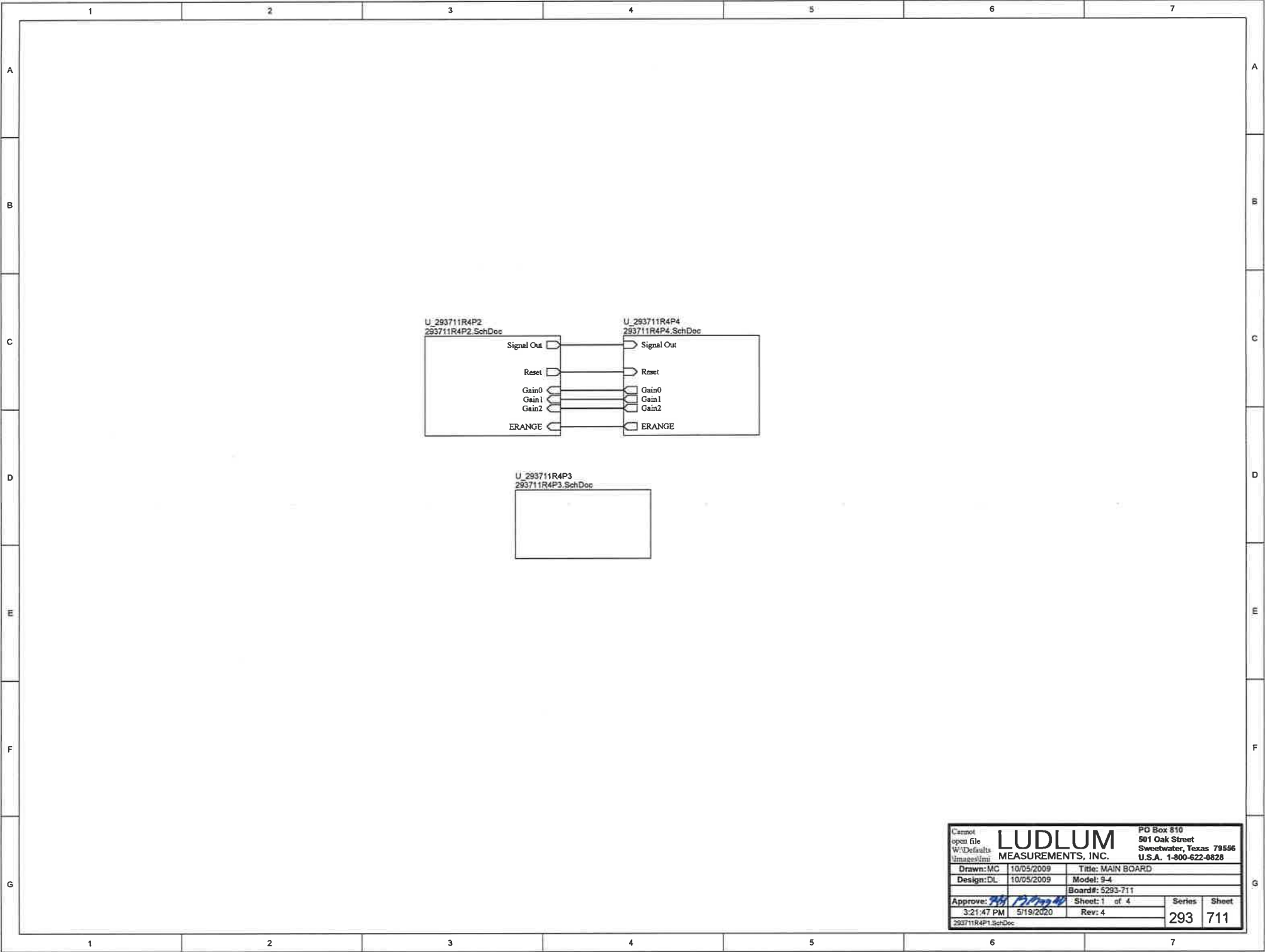

Cannot open file W:\Defaults Images\lmi		LUDLUM MEASUREMENTS, INC.		PO Box 810 501 Oak Street Sweetwater, Texas 79556 U.S.A. 1-800-622-0828	
Drawn: MC	10/05/2009	Title: MAIN BOARD			
Design: DL	10/05/2009	Model: 9-4		Board#: 5293-711	
Approve: <i>[Signature]</i>	3:21:47 PM 5/19/2020	Sheet: 1 of 4	Rev: 4	Series	Sheet
293711R4P1.SchDoc				293	711

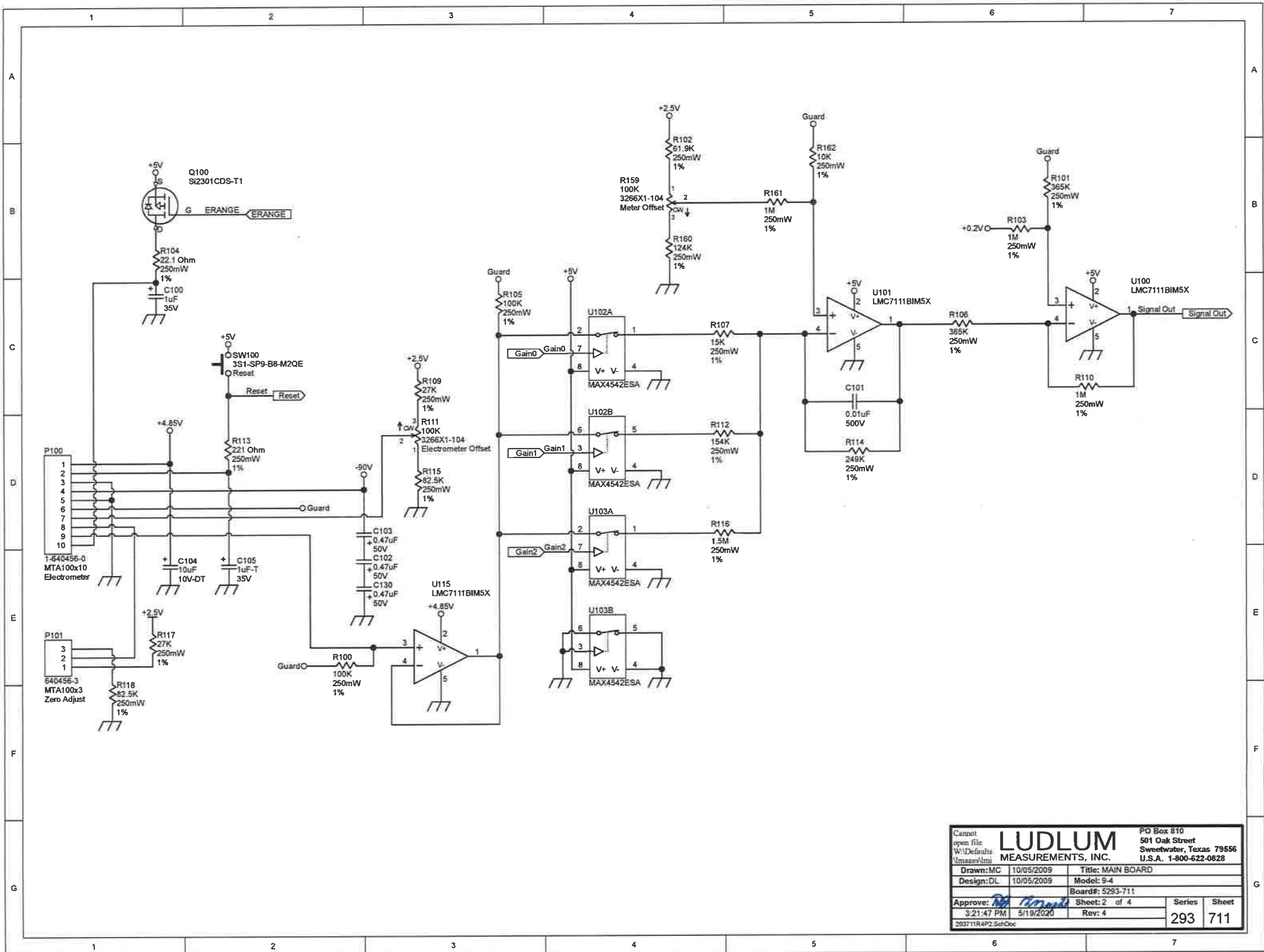

Cannot open file W:\Defaults\Images\Alt		LUDLUM MEASUREMENTS, INC.		PO Box 810 501 Oak Street Sweetwater, Texas 79556 U.S.A. 1-800-622-0828	
Drawn: MC	10/05/2009	Title: MAIN BOARD			
Design: DL	10/05/2009	Model: 9-4		Board#: 5293-711	
Approve: <i>[Signature]</i>	3:21:47 PM 5/19/2020	Sheet: 2 of 4		Series	Sheet
		Rev: 4		293	711

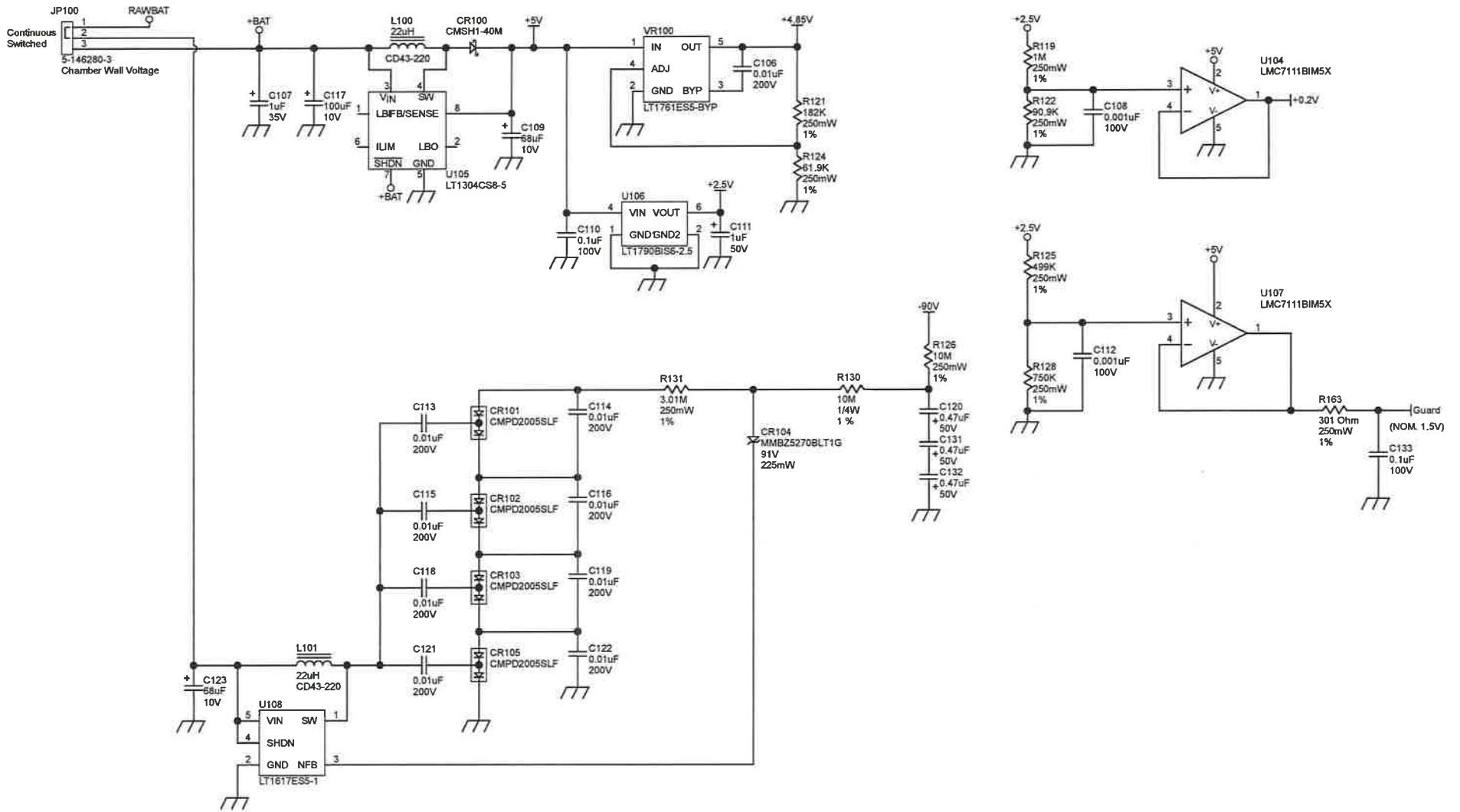

Cannot open file
 W:\Default
 Image\Um

LUDLUM
 MEASUREMENTS, INC.

PO Box 810
 501 Oak Street
 Sweetwater, Texas 79556
 U.S.A. 1-800-622-0828

Drawn: MC	10/05/2009	Title: MAIN BOARD
Design: DL	10/05/2009	Model: 9-4
Approved: <i>[Signature]</i>	3:21:47 PM 5/19/2020	Sheet: 3 of 4
299711R4P3.SchDoc		Rev: 4

Series: 293 Sheet: 711

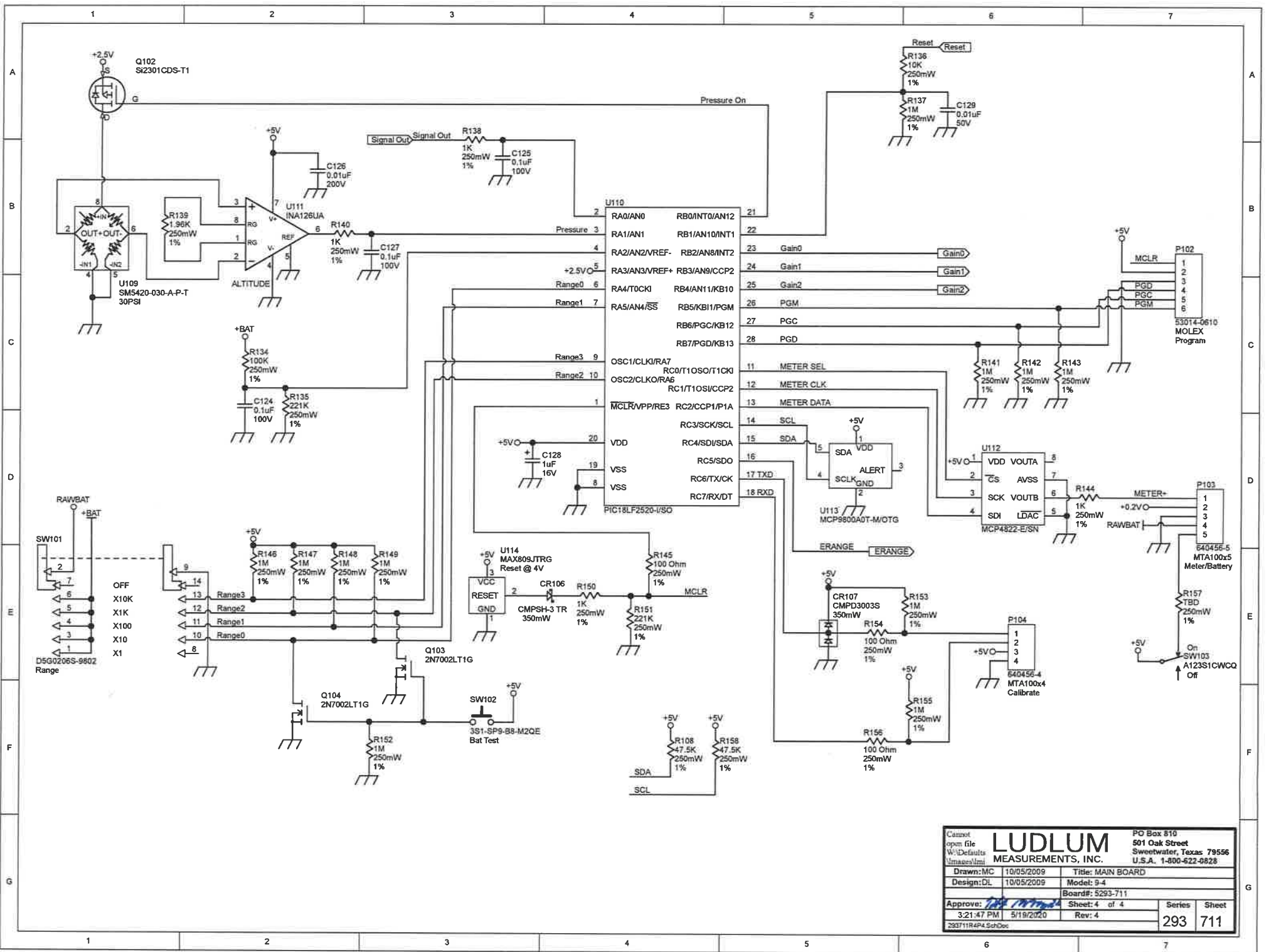

Cannot open file
 W:\Defaults\Umanua\lmi

LUDLUM
 MEASUREMENTS, INC.

PO Box 810
 501 Oak Street
 Sweetwater, Texas 79556
 U.S.A. 1-800-622-0828

Drawn: MC	10/05/2009	Title: MAIN BOARD
Design: DL	10/05/2009	Model: 9-4
Board#: 5293-711		
Approve: <i>[Signature]</i>	Sheet: 4 of 4	Series: 293
3:21:47 PM 5/19/2020	Rev: 4	Sheet: 711

293711R4P4.SchDoc

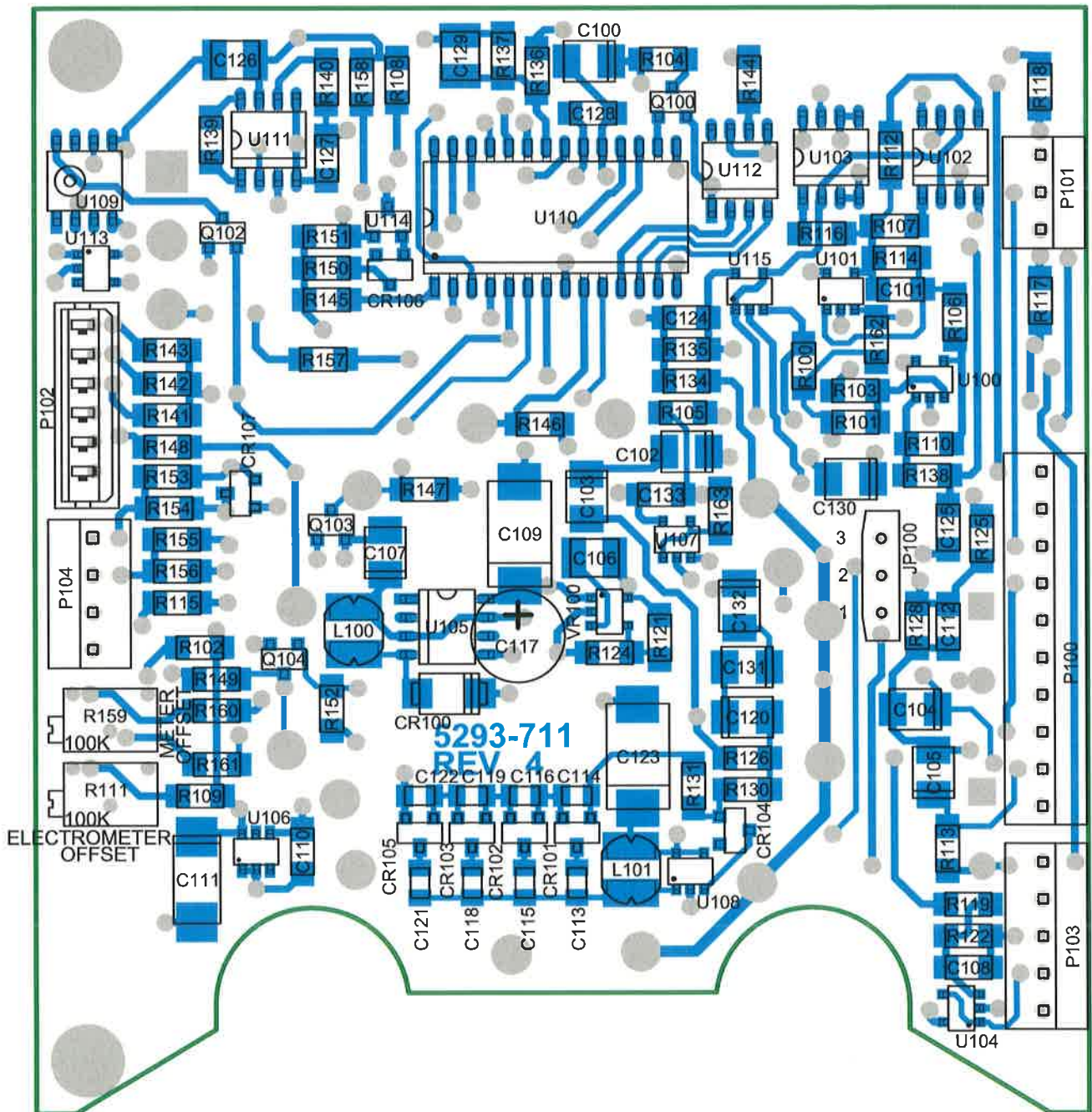

LUDLUM MEASUREMENTS, INC.
 PO Box 810
 501 Oak Street
 Sweetwater, TX 79556
 U.S.A. 1-800-622-0828

Title: MAIN BOARD			
Drawn: MC	10/05/2009	Model: 9-4	
Design: DL	10/05/2009	Board#: 5293-711	
Approve: <i>PLS</i>	<i>10/15/20</i>	Rev: 4	
Print Date: 5/19/2020 2:59:55 PM		SCALE: 1.08 Top Overlay	Series 293 Sheet 712 A

\\freedom\pcb\Projects\LMM 9-4\5293-711\Rev4\293711R4 Assy.PcbDoc

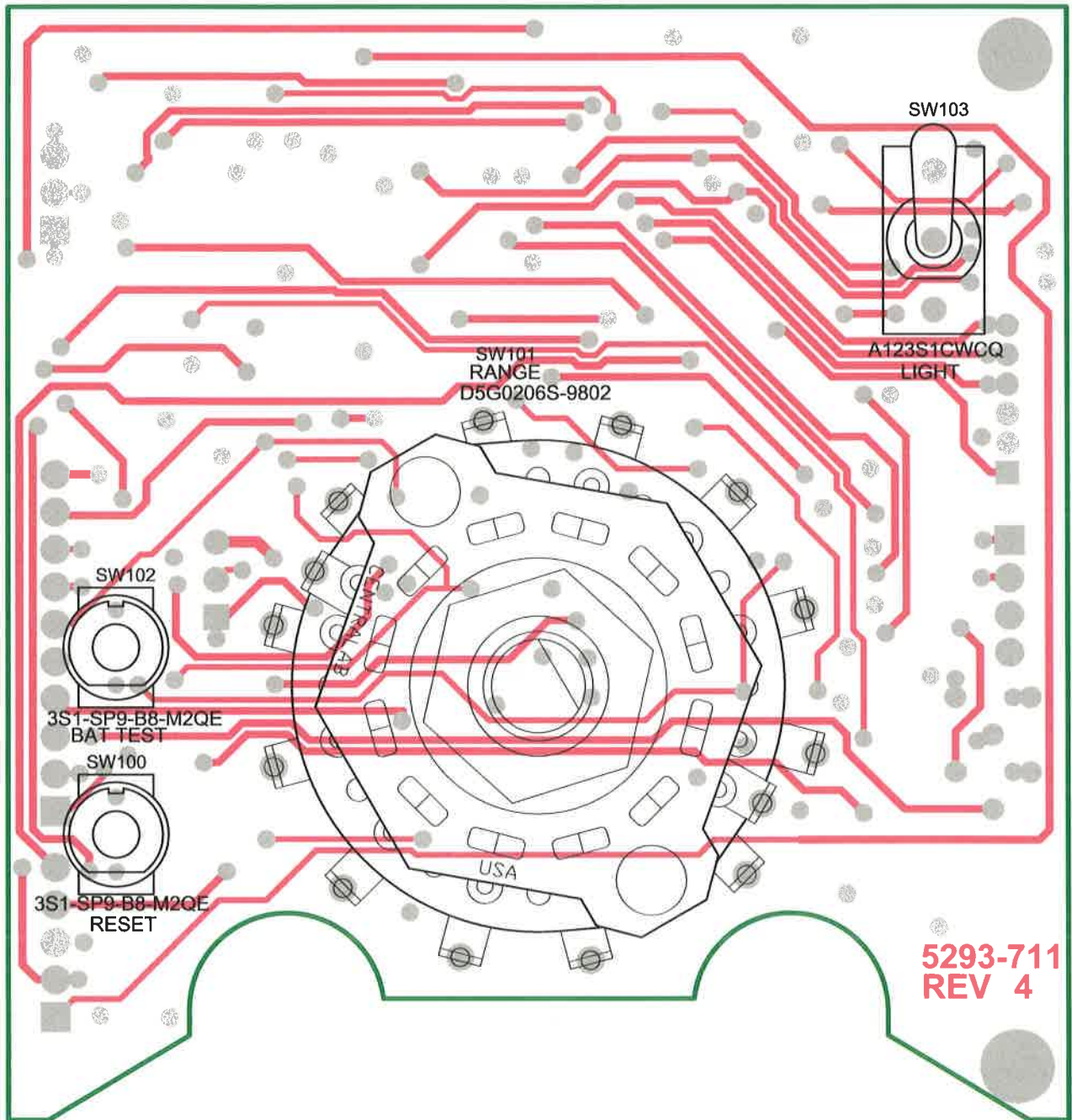

5293-711
REV 4

 LUDLUM MEASUREMENTS, INC.		PO Box 810 501 Oak Street Sweetwater, TX 79556 U.S.A. 1-800-622-0828	
Title: MAIN BOARD			
Drawn: MC	10/05/2009	Model: 9-4	
Design: DL	10/05/2009	Board#: 5293-711	
Approve: <i>DL</i>	<i>10/05/09</i>	Rev: 4	
Print Date: 5/19/2020 3:00:00 PM		SCALE: 1.08	Series Sheet
		Bottom Overlay	293 712 A
<small>\\freedom\pcb\Projects\MM 9-4\5293-711\Rev4\293711R4 Assy.PcbDoc</small>			

1

2

3

4

5

A

B

C

D

E

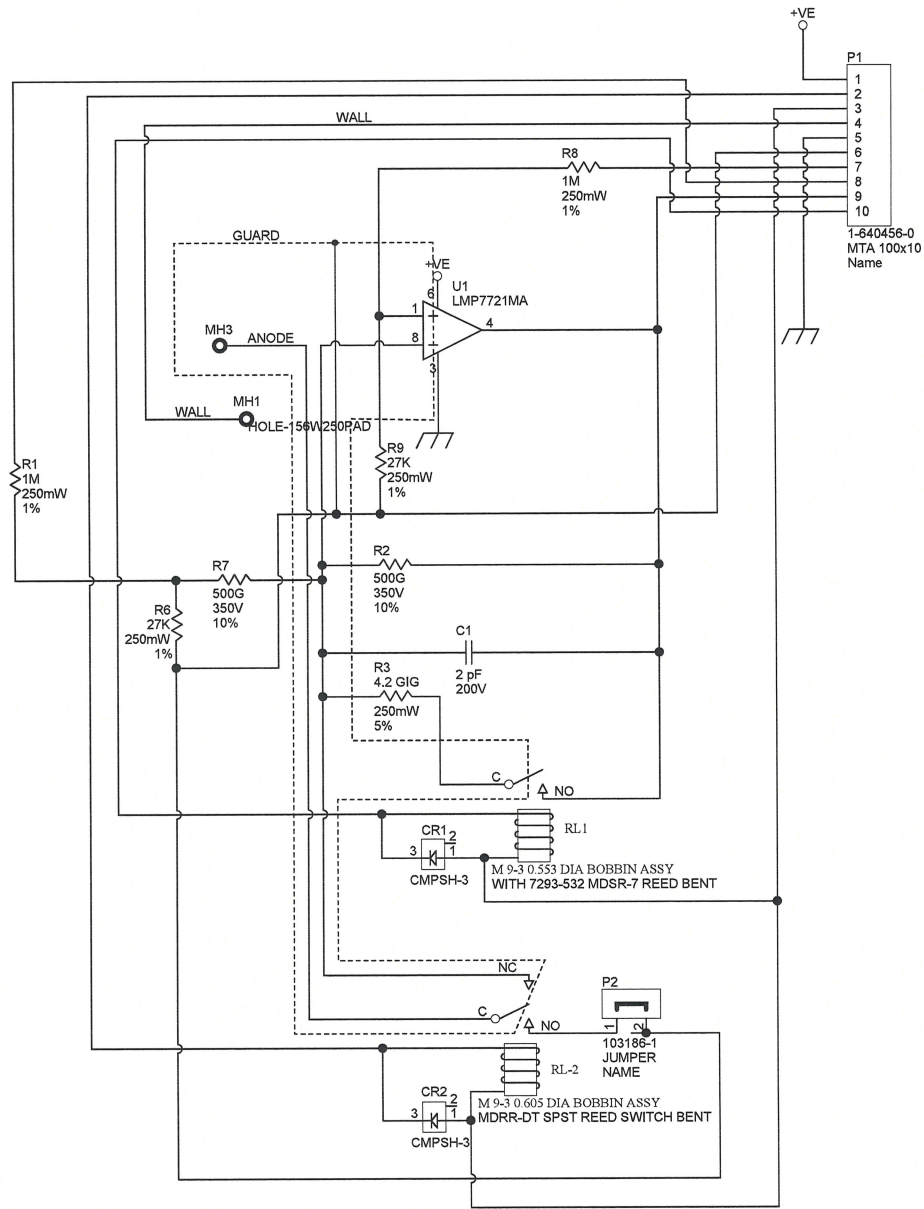
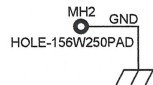

		PO Box 810 501 Oak Street Sweetwater, Texas 79556 U.S.A. 1-800-622-0828	
Drawn: ALC	10/16/2012	Title: ELECTROMETER BOARD	
Design: DL	10/16/2012	Model: 9-3/9-4	
Approve:		Board#: 5293-670	
Print Date: 10/17/2012 8:07:15 AM	Sheet: 1 of 1	Series	Sheet
W:\Project\LMIM 9-3\5293-670\Rev2\293670R2P1.SchDoc		293	670

1

2

3

4

5

