

**LUDLUM MODEL 3030 & 3030E SERIES
ALPHA-BETA SAMPLE COUNTER**

June 2023

**Serial Number 185762 and Succeeding
Serial Numbers**

LUDLUM MODEL 3030 & 3030E SERIES ALPHA-BETA SAMPLE COUNTER

June 2023

Serial Number 185762 and Succeeding
Serial Numbers



LUDLUM MEASUREMENTS, INC.
501 OAK STREET, P.O. BOX 810
SWEETWATER, TEXAS 79556
325-235-5494, FAX: 325-235-4672

STATEMENT OF WARRANTY

Ludlum Measurements, Inc. warrants the products covered in this manual to be free of defects due to workmanship, material, and design for a period of twelve months from the date of delivery. The calibration of a product is warranted to be within its specified accuracy limits at the time of shipment. In the event of instrument failure, notify Ludlum Measurements to determine if repair, recalibration, or replacement is required.

This warranty excludes the replacement of photomultiplier tubes, G-M and proportional tubes, and scintillation crystals which are broken due to excessive physical abuse or used for purposes other than intended.

There are no warranties, express or implied, including without limitation any implied warranty of merchantability or fitness, which extend beyond the description of the face there of. If the product does not perform as warranted herein, purchaser's sole remedy shall be repair or replacement, at the option of Ludlum Measurements. In no event will Ludlum Measurements be liable for damages, lost revenue, lost wages, or any other incidental or consequential damages, arising from the purchase, use, or inability to use product.

RETURN OF GOODS TO MANUFACTURER

If equipment needs to be returned to Ludlum Measurements, Inc. for repair or calibration, please send to the address below. All shipments should include documentation containing return shipping address, customer name, telephone number, description of service requested, and all other necessary information. Your cooperation will expedite the return of your equipment.

**LUDLUM MEASUREMENTS, INC.
ATTN: REPAIR DEPARTMENT
501 OAK STREET
SWEETWATER, TX 79556**

**800-622-0828 325-235-5494
FAX 325-235-4672**

REV #	ALTERATIONS	DATE	BY
1	VALID	9-26-00	JGW
2	ECF 1,837	10-08-04	CLW
3	ROTATED SWITCH (08-6819) 180°	3-28-05	CMC
4	ECF# 4186	9-21-17	CMC

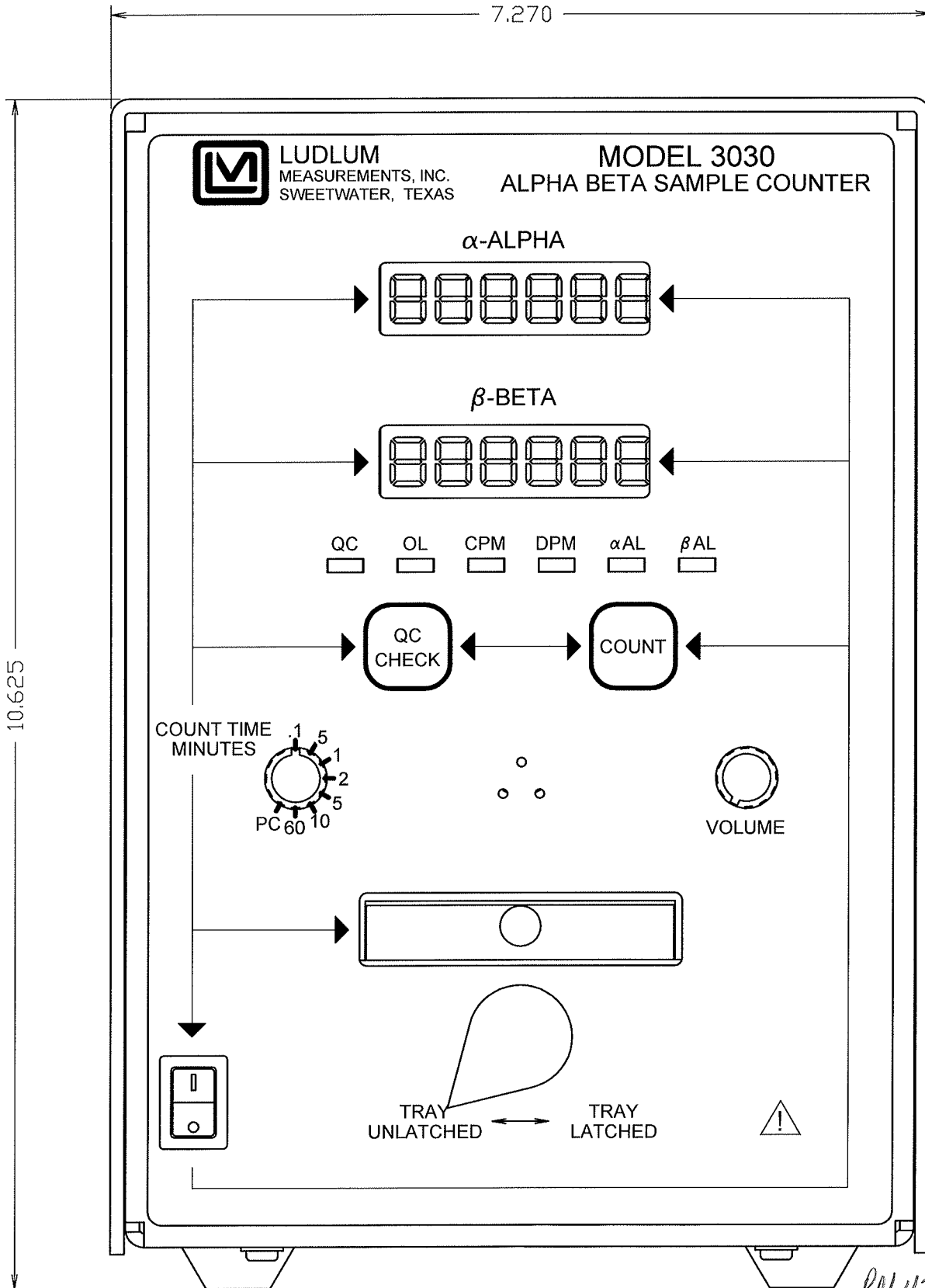

PN 4337-1100

DWN CMC	DATE 9-21-17	CHECKED	APPROVED <i>WJA 9-21-17</i>
TITLE: M 3030 FRONT VIEW			
LUDLUM MEASUREMENTS, INC. 501 DAK STREET SWEETWATER, TEXAS 79556		SERIES 337	SHEET 160E

REV #	ALTERATIONS	DATE	BY
1	VALID	5-10-02	JGW
2	ECF 1,837	10-08-04	CLW
3	ADDED DISCARD SYMBOL	11-2-05	CMC

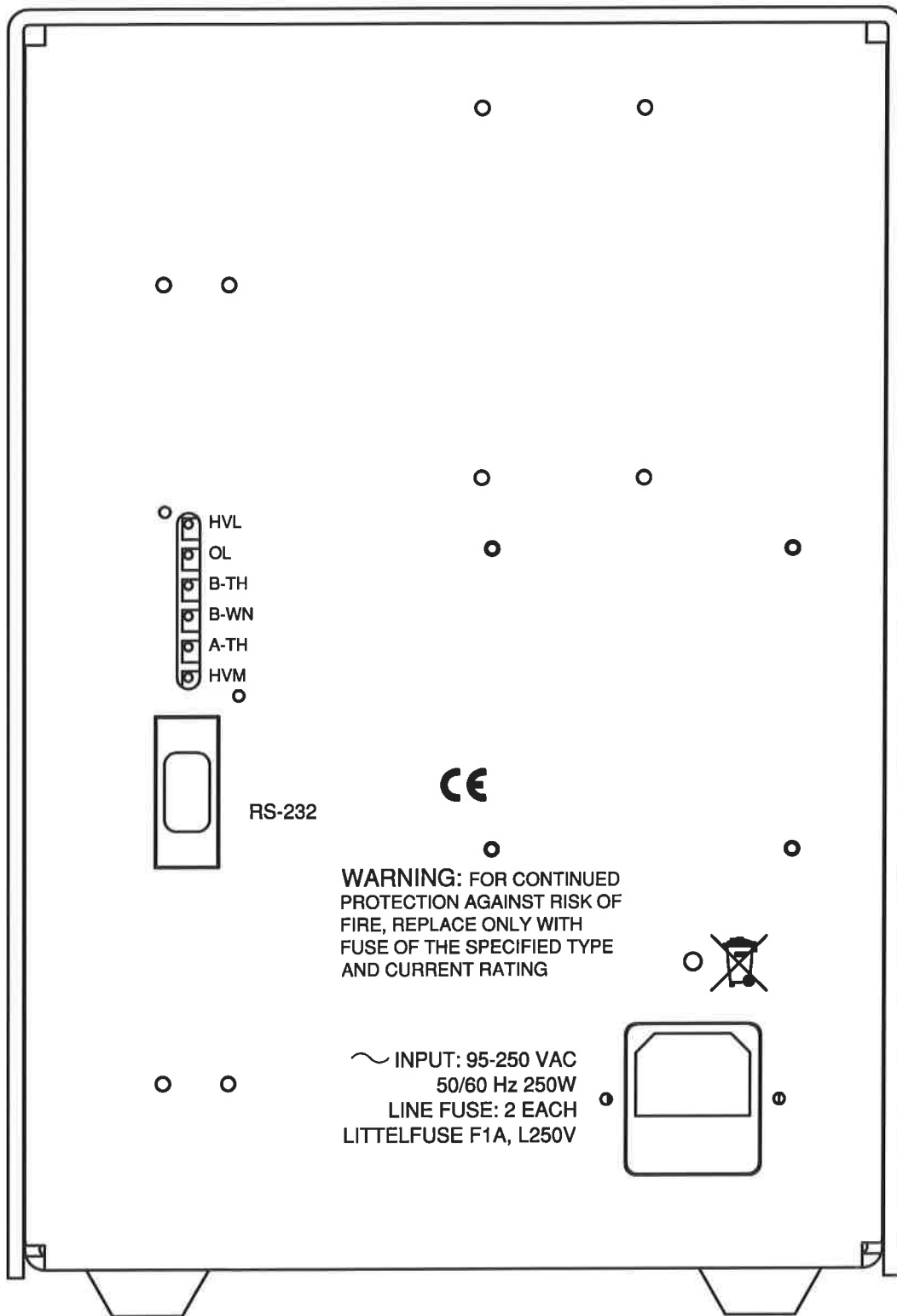

DMN	DATE	CHECKED	APPROVED
CMC	11-2-05		JGW 11-2-05
TITLE: M 3030 REAR VIEW			
LUDLUM MEASUREMENTS, INC. ONE ONE STREET SWEETWATER, TEXAS 75686		SERIES	SHEET
		337	160F

REV #	ALTERATIONS	DATE	BY
1	VALID	11-29-04	CMC
2	ROTATED SWITCH (08-6715) 180°	3-28-05	CMC
3	ECF# 4186	9-21-17	CMC



LUDLUM
MEASUREMENTS, INC.
SWEETWATER, TEXAS

MODEL 3030E
ALPHA BETA
SAMPLE COUNTER

α -ALPHA

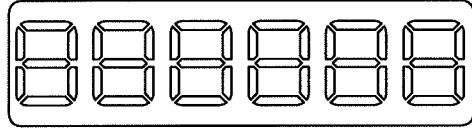

β -BETA

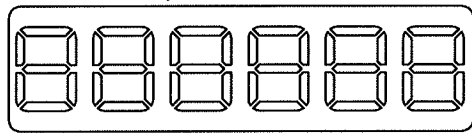

QC OL CPM DPM α AL β AL

QC
CHECK

COUNT

COUNT TIME
MINUTES

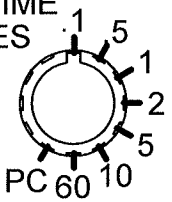

VOLUME

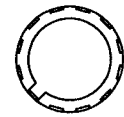

8.550

5.207

DWN	DATE	CHK	DATE	APP	DATE
CMC	9-21-17			WJM	9-21-17
DWG NUM: 4337-171		SCALE: FULL <input checked="" type="checkbox"/> OTHER			
TITLE M 3030E FRONT VIEW					
LUDLUM MEASUREMENTS, INC. 501 DAK STREET SWEETWATER, TEXAS 79556		SERIES	SHEET		
		337	171E		

1/2

REV #	ALTERATIONS	DATE	BY
1	VALID	11-29-04	CMC
2	ADDED DISCARD SYMBOL	11-2-05	CMC

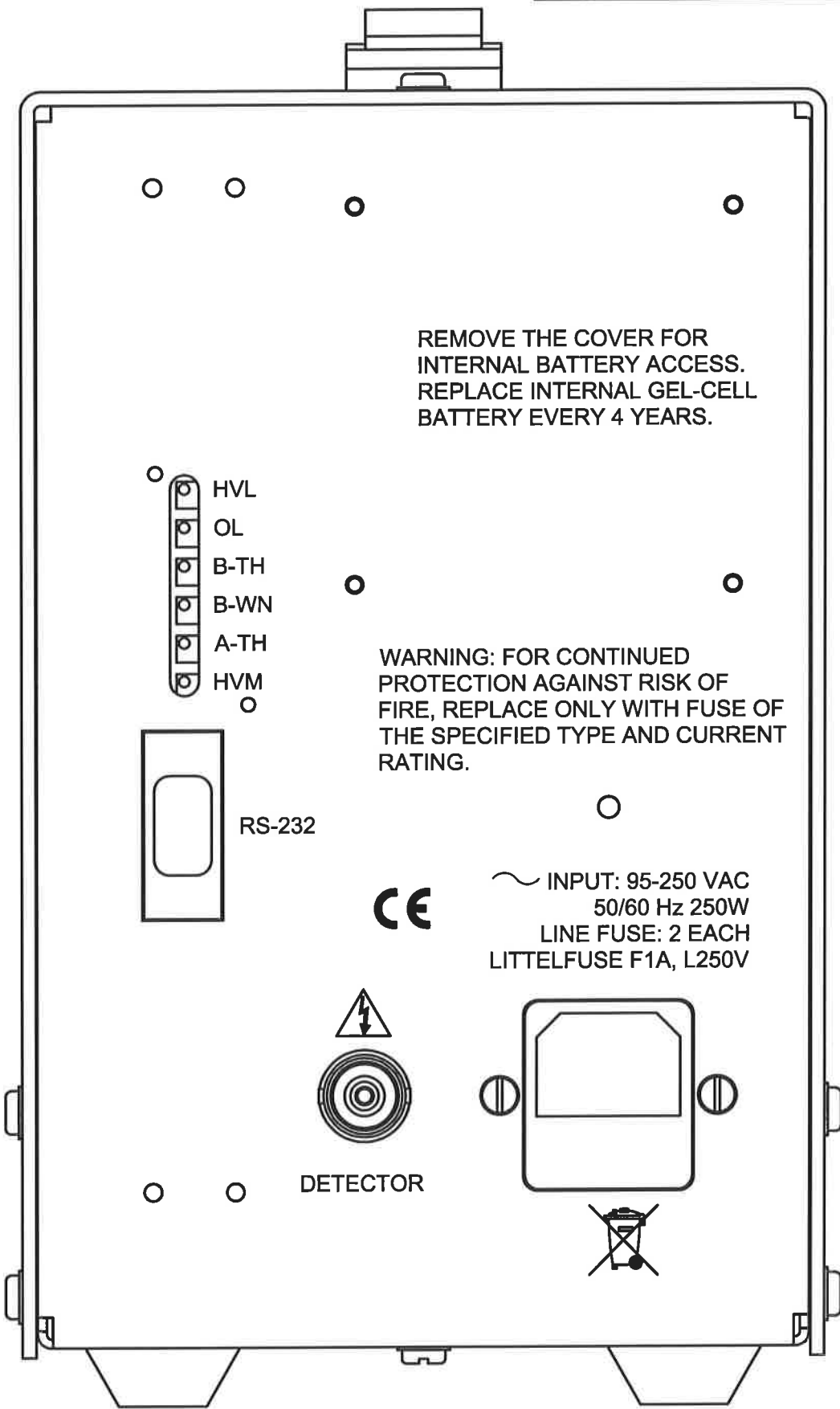

DWN CMC	DATE 11-2-05	CHK NEW	DATE 11-2-05	APP NEW	DATE 11-2-05
DWG NUM: 4337-171		SCALE: FULL <input checked="" type="checkbox"/> OTHER			
TITLE: M 3030E REAR VIEW					
LUDLUM RESEARCH, INC. 591 GAK STREET EVERETT, TEXAS 75626		SERIES 337	SHEET 171F		

REV #	ALTERATIONS	DATE	BY
1	VALID	10-15-12	RHS
2	ECF# 4186	9-22-17	CMC

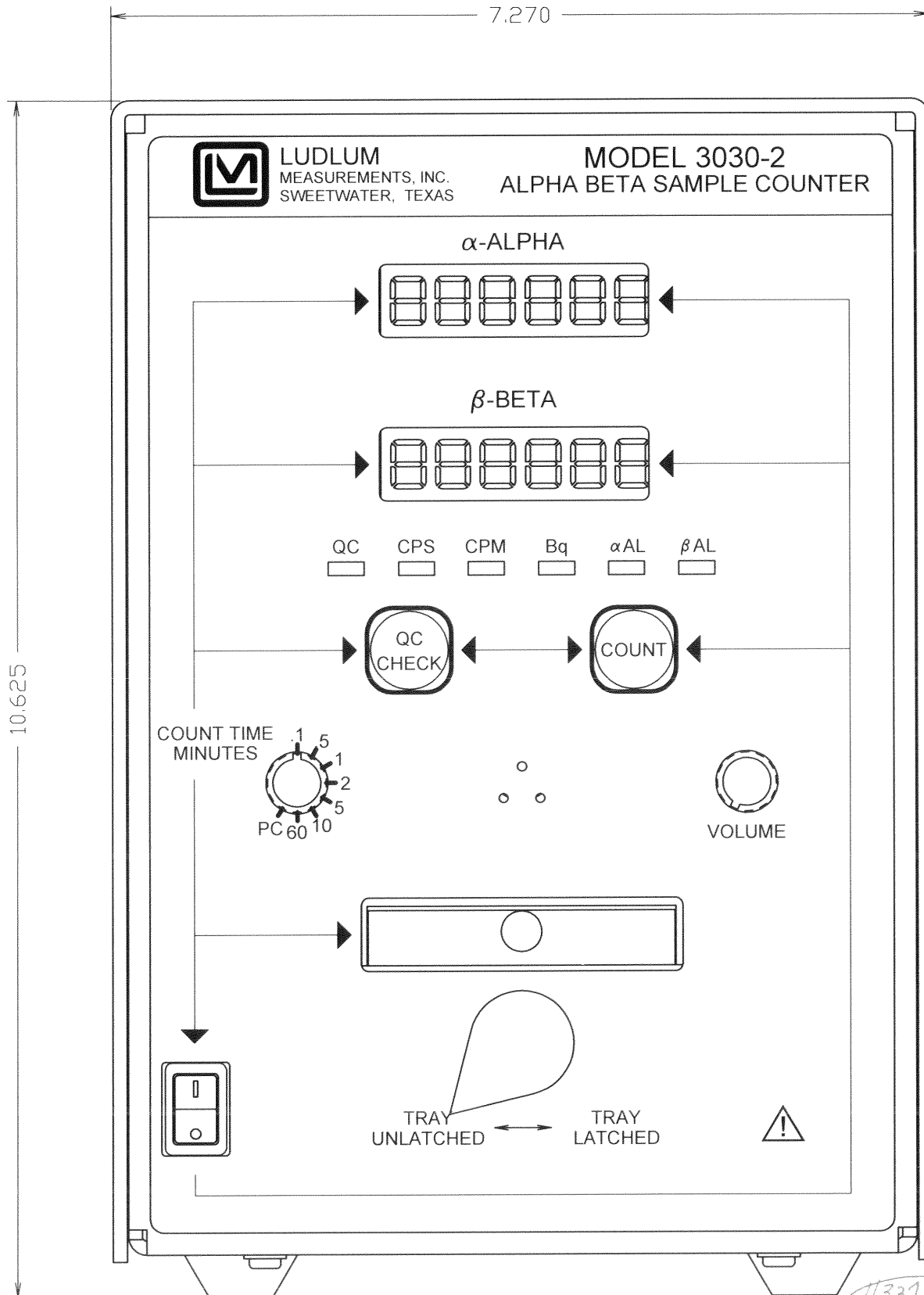

4331-342

DWN	DATE	CHECKED	APPROVED
CMC	9-22-17		WJA 9-22-17
TITLE: M 3030-2 FRONT VIEW			
LUDLUM MEASUREMENTS, INC. 501 DAK STREET SWEETWATER, TEXAS 79556		SERIES 337	SHEET 342E

K

REV #	ALTERATIONS	DATE	BY
1	VALID	9-22-17	CMC



LUDLUM
MEASUREMENTS, INC.
SWEETWATER, TEXAS

MODEL 3030E-2
ALPHA BETA
SAMPLE COUNTER

α -ALPHA

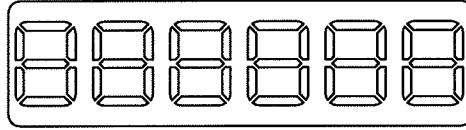

β -BETA

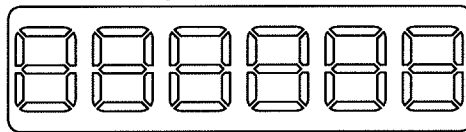

QC

CPS

CPM

Bq

α AL

β AL



QC
CHECK

COUNT

COUNT TIME
MINUTES

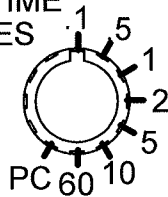

VOLUME

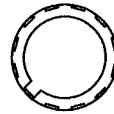

8.550

5.207

DWN CMC	DATE 9-22-17	CHK	DATE	APP J60	DATE 9-22-17
DWG NUM: 4337-372		SCALE: FULL <input checked="" type="checkbox"/> OTHER			
TITLE M 3030E-2 FRONT VIEW					
LUDLUM MEASUREMENTS, INC. 501 BAK STREET SWEETWATER, TEXAS 79556		SERIES 337	SHEET 372		

Table of Contents

INTRODUCTION	1
GETTING STARTED	3
Unpacking and Repacking	3
Software Installation	4
External Counter HV Connector (3030E only).....	4
Start-up.....	4
SPECIFICATIONS	6
Model 3030 ONLY	6
Model 3030E ONLY	6
Common Specifications	7
DESCRIPTION OF CONTROLS AND FUNCTIONS	8
Front Panel	8
Back Panel.....	9
Internal Controls	10
SAFETY CONSIDERATIONS	11
Environmental Conditions for Normal Use.....	11
Cleaning Instructions and Precautions.....	11
Warning Markings and Symbols	12
Replacement of Main Fuse (Back Panel).....	13
CALIBRATION AND MAINTENANCE	14
Calibration	14
Recommended Sources	14
Calibration Procedure.....	15
Maintenance	18
COMPUTER SOFTWARE	20
Parameters	22

QC Check	25
Steps for Performing a QC Check	27
HV Plateau	29
Steps for Performing a High-voltage Plateau	29
MDA Calculations	32
Data Logging	33
RS-232 Communication	34
COMMANDS	34
Sample Printouts	41
Software License Agreement	43
SOFTWARE CHANGES	45
RECYCLING	49
PARTS LIST	50
Model 3030 & Model 3030E Alpha-Beta Sample Counters	50
Amplifier / Processor Board, Drawing 337 × 365.....	50
CRYSTALS	50
CAPACITORS.....	50
TRANSISTORS.....	51
INTEGRATED CIRCUITS	51
DIODES.....	51
POTENTIOMETERS	52
RESISTORS	52
TRANSFORMERS.....	53
CONNECTORS.....	53
MISCELLANEOUS	53
Display Board, Drawing 337 × 88	53
CAPACITORS.....	53
TRANSISTORS.....	53
INTEGRATED CIRCUITS.....	53
RESISTORS	53
MISCELLANEOUS	53
Power Supply Board, Drawing 337 × 133	54
CAPACITORS.....	54
VOLTAGE REGULATOR.....	54
INTEGRATED CIRCUITS.....	54
DIODES.....	54
RESISTORS	54
CONNECTORS.....	54
INDUCTORS.....	54
Wiring Diagram, Drawing 337 × 182	54
SWITCHES	54
POTENTIOMETER	55

CONNECTORS.....	55
MISCELLANEOUS	55
Model 3030 ONLY	55
DRAWINGS AND DIAGRAMS	56
MODEL 3030-2 AND 3030E-2.....	A-1
MODEL 3030 DC MODIFICATION.....	B-1

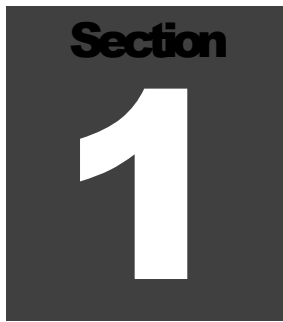
A dark gray square graphic with the word "Section" in white at the top and a large white number "1" in the center.

Introduction

The Model 3030 and 3030E are dual-channel counters designed for simultaneous alpha and beta sample measurement. The Model 3030 has a built-in scintillation detector with a shielded chamber and chrome-plated brass sample tray that can accept a maximum sample size of 5.1 cm (2 in.) in diameter. The Model 3030E utilizes an external, side mounted sample counter. Common external counters are: the alpha-only, Model 43-10, or the alpha-beta, Model 43-10-1. Throughout this manual, the term “3030” will be used to refer to both instruments unless otherwise noted.

The Model 3030 is powered by main supply of 95-250 Vac. The instrument features a built-in detector, high-voltage power supply, adjustable count time periods, and a click-per-event audio with adjustable volume. A pulse height analyzer is employed to provide information to the two independent counters. The Model 3030 also features an internal trickle-charged gel-cell battery for providing up to eight hours of use without mains supply. The two independent LCDs (liquid crystal displays) feature six 1.3 cm (0.5 in.) tall digits, which are backlit for improved visibility.

The instrument may be operated as a traditional scaler (counts per count time) with a manually adjustable high voltage, or may be enabled to operate with advanced features. The 9-pin RS-232 connector on the back of the instrument allows attachment to a computer or printer. Software is provided to allow the setup of several advanced features.

The counts per minute (CPM) or disintegrations per minute (DPM) modes may be enabled to allow the count to be converted (automatically, in real time) to cpm or dpm. The background radiation count may be subtracted automatically in either mode. Crosstalk correction, alpha or beta alarms, and time/date may also be set. Parameters are stored in non-volatile memory. Time and date are maintained with an internal lithium battery.

Another advanced feature, which may be enabled or disabled, is the QC (Quality Control) check function. When enabled, the user must perform

measurements on known sources (and background) and receive acceptable numbers in order for the instrument to be used that day. Twenty-four hours later, the QC LED (light emitting diode) is turned on, indicating the need for another QC check. This feature ensures that the instrument is tested daily and that measurements are valid.

The Model 3030-2 is a variant of the Model 3030 that allows the count to be displayed in units of Bq or CPS (counts per second). In order to do this, the status light for overload (OL) is changed to a green indicator, and the overload condition is instead displayed as "OL" on both LCD displays. The final change is that, when placed into Bq or CPS units, the alpha and beta LCD displays are changed to having a second decimal point, ie. in the format xxxx.xx to allow for lower-level measurements. The Model 3030-2 does have a distinctly different front panel that has the model number "3030-2" prominently displayed. A detailed summary of these changes are found in Appendix A, starting with page A-1.

The Model 3030E-2 is like the Model 3030-2, but with an external detector like the Model 3030E.

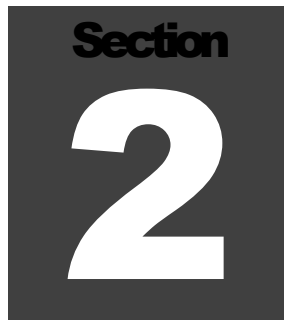
A dark gray square with the word "Section" in white at the top and a large white number "2" in the center.

Getting Started

Unpacking and Repacking

Caution

The Model 3030 Alpha-Beta Scaler weighs approximately 13.2 kg (29 lb). Take necessary precautions when lifting the instrument to prevent personal injury or strain.

Remove the calibration certificate and place it in a secure location. Remove the instrument and accessories (batteries, cable, etc.) and ensure that all of the items listed on the packing list are in the carton. Check individual item serial numbers and ensure calibration certificates match. The Model 3030/3030E serial number is located on the back panel, lower left-hand corner. Most Ludlum Measurements, Inc. detectors have a label on the base or body of the detector for model and serial number identification.

Important!

If multiple shipments are received, ensure that the detectors and instruments are not interchanged (particularly in the case of the Model 3030E). Each instrument is calibrated to a specific detector(s), and is therefore not interchangeable.

To return an instrument for repair or calibration, provide sufficient packing material to prevent damage during shipment. Also provide appropriate warning labels to ensure careful handling.

Every returned instrument must be accompanied by an **Instrument Return Form**, which can be downloaded from the Ludlum website at www.ludlums.com. Find the form by clicking the “Support” tab and selecting “Repair and Calibration” from the drop-down menu. Then choose the appropriate Repair and Calibration division where you will find a link to the form.

Software Installation

Interface software supplied with the instrument will need to be installed if access to advanced features is desired. User must comply with the software license agreement found in Section 7 of this manual.

Install the Model 3030 interface software before making any connections between the instrument and a computer.

Note:

Uninstall any previous version of the Model 3030 interface software prior to installing this version.

Place the CD in the computer CD drive. The software will automatically install. If desired, double-click “setup.exe” to manually install the software.

After the automatic installation program begins, follow the prompts. Take note of the directory to which the executable file is saved. After completion of the installation, the program may be accessed through the directory in which it was saved.

External Counter HV Connector (3030E only)

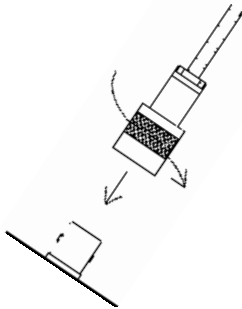
**Caution!**

The external counter operating voltage (HV) is supplied to the counter via the counter input connector. A mild electric shock may occur if bodily contact is made with the center pin of the input connector. Switch to OFF before connecting or disconnecting the cable or counter.

Connect one end of a counter cable to the counter by firmly pushing the connectors together while twisting clockwise a quarter of a turn. Repeat the process in the same manner with the other end of the cable and the instrument.

Start-up

Before using the instrument for the very first time, determine whether or not a computer interface is desired. If the computer interface is desired, revert to the previous subsection, “Software Installation,” before continuing, and then connect the instrument to the computer using the RS-232 cable provided.

Connect the instrument to mains power using the power cable provided and then turn the instrument on “|” using the front panel power switch (lower left corner).

Upon power-up, the LCD displays become backlit, front panel indicators (LEDs) illuminate, and the alpha display shows all eights (888888). Then the firmware version is displayed. Parameters will display before initialization completes if the “Show Parameters during power-up” box is checked in “General Settings” within the interface program. After initialization is complete, both displays are blanked, and all front-panel indicators (LEDs) are turned off.

If using the computer interface, start the interface program from the appropriate directory and set the desired operating parameters described in detail in Section 6 of this manual

Perform a QC check by following the directions imprinted on the instrument front panel if available, ensuring the tray latch switch (Model 3030) is placed in the TRAY UNLATCHED position before attempting to pull out the tray. Once the tray is slid out, place the check source in the center, slide the tray back in place, and place the tray latch switch in the TRAY LATCHED position. See Section 6 of this manual for further details on “QC Check.”

The COUNT TIME MINUTES switch should be set based on the count rates being observed and the desired statistical accuracy. Set the VOLUME control to the desired level of audio.

Proceed to use the instrument. For further information on instrument controls or functions, consult Sections 4 and 7 of this manual.

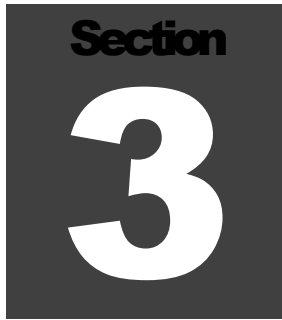
A dark gray square with the word "Section" in white at the top and a large white number "3" in the center.

Specifications

Model 3030 ONLY

Detector: ZnS(Ag) adhered to a plastic scintillation material

Tube: 5.1 cm (2 in.) diameter, magnetically shielded photomultiplier

Window: 0.4 mg/cm² aluminized Mylar

Active and Open Area: 20.3 cm²

Sample Holder: brass housing with chrome-plated brass sample tray, capable of holding 2.5 or 5.1-centimeter (one or two-inch) diameter samples, up to 1 cm (0.4 in.) thick

Shielding Thickness: 19 mm (0.75 in.)

Efficiency (4 π geometry):

Alpha: 32% for ²³⁰Th; 39% for ²³⁸U; 37% for ²³⁹Pu

Beta: 8% for ¹⁴C; 27% for ⁹⁹Tc; 29% for ¹³⁷Cs; 26% for ⁹⁰Sr/⁹⁰Y

Background:

Alpha: 3 cpm or less

Beta Gamma: 50 cpm or less (10 μ R/hr field)

Size: 29.2 x 19.1 x 26.7 cm (11.5 x 7.5 x 10.5 in.) (H x W x D)

Weight: 13.2 kg (29 lb)

Finish: gray powder coating with subsurface-printed membrane front panel

Model 3030E ONLY

Counter Connector: series "C" for connection to an external counter

Size: 24.1 x 13.5 x 25.4 cm (9.5 x 5.3 x 10.0 in.) (H x W x D)

**Common
Specifications**

Weight: 2.7 kg (6 lb)

Finish: beige powder coating with subsurface-printed membrane front panel

Input Sensitivity: Beta-gamma lower threshold is adjustable from 2 mV to 10 mV. Beta-gamma upper threshold is adjustable from 25 mV to 100 mV. Alpha threshold is adjustable from 150 mV to 500 mV. Normally the beta channel is set for input pulses from 4 mV to 50 mV, and the alpha channel is set for input pulses above 120 mV.

Beta Threshold: -4 mV

Alpha Threshold: -120 mV

Beta Window: 50 mV

High Voltage (HV): manually or digitally adjustable from 200 to 2500 Vdc with the capability of supporting 60-megohm scintillation loads to 1500 volts

Audio: dual tone (one for each channel), “click-per-event” type with volume control

Data Output: 9-pin RS-232 port

Status Indicators: backlit indicators for QC-daily QC check needed; OL-scintillation detector is in overload condition; CPM/DPM- counting in CPM or DPM mode; α AL/ β AL-count has exceeded the alarm set point

Count Time: Select 0.1, 0.5, 1, 2, 5, 10, 60 minutes or the user-defined PC setting, which is defined during setup using the RS-232 port. User-defined count time may be set from 0.1 to 546.1 minutes.

Scalers: two each (one per channel), six-digit LCD displays with backlights providing a range of 0-999999 counts (started by the COUNT button)

Scaler Linearity: reading within 2% of true value

Count Timer: adjustable from 0.1 to 30 minutes (PC setting is user-defined via PC software)

Power: 250 watts at 95-250 Vac, 50-60 Hz single phase; internal 12 Vdc, 1.2A/hr, trickle-charged battery provides power for eight hours

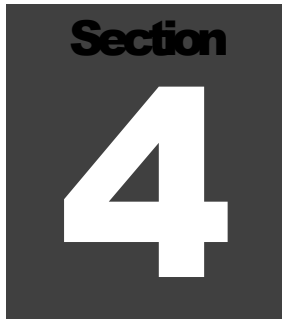
A dark gray square containing the word "Section" in a white sans-serif font at the top, and a large white number "4" in the center.

Description of Controls and Functions

Front Panel

ON/OFF: a rocker switch used to apply power to the instrument when in the ON position

COUNT Button: resets and starts the counting cycle, also resets the two counters when depressed

QC CHECK Button: starts the QC (Quality Control) Check cycle, also resets the two counters when depressed. Pressing this button during a QC Check will restart the process. Press the COUNT Button to advance to the next step.

COUNT TIME (MINUTES): a rotary switch, allowing selection of count times of 0.1, 0.5, 1, 2, 5, 10, 60 or a PC position that selects the user-defined count time

VOLUME: a rotary control used to vary the audio output from off to full volume

Tray: a slide-out tray is used to hold the sample during a count cycle. The tray will hold samples, which are up to 1 centimeter (0.4 inches) thick by either 2.5 or 5.1 centimeters (one or two inches) in diameter. The tray insert is held in place by a set screw (left side) and is reversible (by loosening the set screw) for selection of sample diameter.

Tray Switch (Model 3030 only) (Marked TRAY LATCHED and TRAY UNLATCHED): a 90° rotary control used to lift the sample tray into position and block all extraneous light from the detector. Tray switch should always be in the LATCHED position while counting. **Notice: The tray switch, when in the open or unlatched position, disables the HV to the detector.**

ALPHA: A six-digit backlit LCD readout indicates counts received in the alpha counting channel.

BETA: A six-digit, backlit LCD readout indicates counts received in the beta counting channel.

QC: A red LED indicator illuminates whenever QC is needed. When a valid QC check is performed, the QC indicator turns off. Additionally, the QC indicator is turned off when the QC check feature is disabled (during setup).

OL: A red LED indicator illuminates whenever the internal circuitry detects a current overload to the detector. This warning usually indicates an open sample tray or a torn window on the front of the internal detector. Instrument will not count while this indicator is illuminated.

CPM: A green LED indicator illuminates whenever CPM mode is established (during setup).

DPM: A green LED indicator illuminates whenever DPM mode is established (during setup).

α AL: A red LED indicator illuminates whenever the alpha count exceeds the alarm level established during setup.

β AL: A red LED indicator illuminates whenever the beta count exceeds the alarm level established during setup.

Back Panel

Detector Input Connection (Model 3030E only): a series "C" coaxial connector; other connectors are available upon request

RS-232: a 9-pin D-connector for connection to printer or computer

CAL: a cover for the calibration potentiometers, which should only be adjusted by trained and authorized personnel during calibration

INPUT: line or mains power receptacle and fuse holder. Use of two one-amp, fast-blowing fuses provides protection to the instrument in case of internal electrical failure.

Remove the calibration (cal) cover plate to access the following calibration potentiometers:

A-TH: a multi-turn potentiometer used to vary the alpha pulse discriminator from 40 to 700 mV, normally set at 120 mV

B-WN: a multi-turn potentiometer used to vary the upper beta pulse discriminator from BT setting to AT setting, normally set at 50 mV

B-TH: a multi-turn potentiometer used to vary the lower beta pulse discriminator from 2 to 15 mV, normally set at 4 mV

OL: a multi-turn potentiometer that provides a means to vary the detector current overload set point

HVL: a multi-turn potentiometer used to calibrate the digital high voltage

HVM: a multi-turn potentiometer used to manually adjust the high voltage when digital control is not desired

Internal Controls

The following dipswitches and jumpers are located on the amplifier/processor board and are only accessible when the cover is removed.

Dipswitch 1: When in the OFF position, the Model 3030 is locked into Scaler mode only. The default position is ON.

Dipswitch 2: When in the ON position, the calibration date is disabled. The default position is ON.

HV Jumper: When shunt is on the two outside pins, the HV is adjusted manually with the HVM potentiometer. The normal shunt position is on the two inside pins.

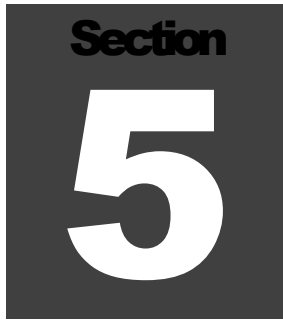
A dark gray square containing the word "Section" in a small, white, sans-serif font at the top. Below it is a large, white, bold number "5".

Safety Considerations

Environmental Conditions for Normal Use

- Indoor use only
- No maximum altitude
- Temperature range of -20 to 50 °C (-4 to 122 °F)
- Maximum relative humidity of less than 95% (non-condensing)
- Mains supply voltage range of 95-250 Vac, 50/60Hz single phase, 250W
- Maximum transient voltage of 1500 Vac
- Installation Category II (Overvoltage Category as defined by IEC 1010-1)
- Pollution Degree 2 (as defined by IEC 664): Normally only nonconductive pollution occurs. Temporary conductivity caused by condensation is to be expected.

Cleaning Instructions and Precautions

The Model 3030 Alpha-Beta Sample Counter may be cleaned externally with a damp cloth, using only water as the wetting agent. Do not immerse the instrument in any liquid. Observe the following precautions when cleaning:

1. Turn the instrument OFF and disconnect the instrument power cord.
2. Allow the instrument to sit for one minute before cleaning.

Warning Markings and Symbols

Caution!

The operator or responsible body is cautioned that the protection provided by the equipment may be impaired if the equipment is used in a manner not specified by Ludlum Measurements, Inc.

Caution!

Verify instrument voltage input rating before connecting to a power converter. If the wrong power converter is used, the instrument and/or power converter could be damaged.

The Model 3030 Alpha-Beta Sample Counter is marked with the following symbols:



ALTERNATING CURRENT (AC) (IEC 417, No. 5032) - designates an input receptacle that accommodates a power cord intended for connection to AC voltages. This symbol appears on the back panel.



PROTECTIVE CONDUCTOR TERMINAL (per IEC 417, No. 5019) – designates the central grounding point for the safety ground. This symbol is visible inside the chassis.



CAUTION (per ISO 3864, No. B.3.1) – designates hazardous live voltage and risk of electric shock. During normal use, internal components are hazardous live. This instrument must be isolated or disconnected from the hazardous live voltage before accessing the internal components. This symbol appears on the front panel. **Note the following precautions:**

Warning!

The operator is strongly cautioned to take the following precautions to avoid contact with internal hazardous live parts that are accessible using a tool:

1. Turn the instrument power OFF and disconnect the power cord.
2. Allow the instrument to sit for one minute before accessing internal components.



CAUTION, RISK OF ELECTRIC SHOCK (per ISO 3864, No. B.3.6) – designates a terminal (connector) that allows connection to a voltage exceeding one kV. Contact with the subject connector while the instrument is on or shortly after turning off may result in electric shock. This symbol appears on the rear panel of the Model 3030E only.



The “**crossed-out wheelie bin**” symbol notifies the consumer that the product is not to be mixed with unsorted municipal waste when discarding; each material must be separated. The symbol is placed near the AC receptacle. See section 8, “Recycling,” for further information.

Replacement of Main Fuse (Back Panel)

Warning!

For continued protection against risk of fire, replace only with fuse of the specified type and current rating!

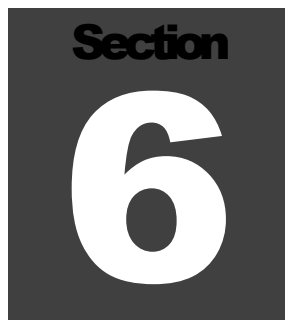
A dark gray square containing the word "Section" in a small, white, sans-serif font at the top, and a large, white, bold number "6" in the center.

Calibration and Maintenance

Calibration

The following calibration procedure is applicable to the Model 3030. Adjustments are necessary if this procedure is used with the Model 3030E. Where applicable, those changes will be noted with regard to the most common external detector used – the Model 43-10-1. Other instrument detector combinations are not covered in this manual. Consult the individual detector manual for the needed specifications.

A Ludlum Model 500 Pulser or equivalent is required. If the pulser does not have a high-voltage readout, use a high-impedance voltmeter with at least 1000 megohm input resistance to measure the detector voltage. Calibrated sources are also required.

Note:

In the Model 3030 only, the tray switch, when in the open or unlatched position, disables the HV to the detector.

Recommended Sources

The recommended sources for use with the Model 3030 are plated ^{239}Pu alpha and ^{99}Tc beta sources. These sources have an active diameter of 3.2 cm (1.3 in.) with an overall diameter of 4.8 cm (1.9 in.). The larger diameter ring gives protection to the source from direct contact as the source is handled. Direct contact, i.e., touching, is a problem as oils from the skin can attenuate or block alpha and beta particles. The recommended activity is approximately 200,000 dpm. Keep in mind that you want good statistics, and to do that you want large numbers in a short amount of time. If you want to count for 60 seconds, than a source size of about 20,000 dpm will generally result in counts (given a 15% 4π efficiency) of 3000 counts. Counting this size source in a tenth of a minute will result in a count of only about 300 above background, and your percentage error will be greater.

Increasing the size of the source to 200,000 dpm gives you better statistics, while allowing you to keep the count time short.

Calibration Procedure

- Perform mechanical checks, such as switch function and illumination of digital readouts.
- Remove the outside cover of the Model 3030. Measure battery voltage and ensure voltage is 13 volts or greater.
- Connect the Model 3030 to the computer and load the default settings. Make sure that the jumper on the amplifier/processor board is on the inside two (2) pins. Ensure that both dipswitches are in the ON position.
- Connect the Model 500 Pulser to the Model 3030 with the appropriate cable. (Computer may stay connected.)
- Adjust the pulser for 400,000 cpm and adjust the pulse amplitude to 4 mV (negative amplitude).
- Adjust the beta threshold (B-TH) and beta window (B-WN) for the appropriate set points: B-TH at 4 mV and B-WN at 50 mV. The pulser counts should be detected on the Model 3030 beta display above 4 mV and should shut off above 50 mV.
- Pulses in the beta channel should be audible. Ensure that the VOLUME control works correctly.
- Set the Model 500 Pulser amplitude switch to 200 mV. With the Model 500 Pulser set to 120 mV, adjust the alpha threshold (A-TH) control for 120 mV.
- Pulses in the alpha channel should be audible.
- Set the HV to 800 Vdc. Using a high-voltage meter, measure the high voltage and adjust the HVL potentiometer on the amplifier/processor board until the high voltage reads 800 Vdc ± 2 Vdc.
- Change the voltage (using the computer) to 500 Vdc and 1500 Vdc. In each case, verify that the high voltage is within $\pm 5\%$ of the correct value.

- Change the shunt on the jumper (amplifier/processor board) to the manual side (outside two [2] pins from the edge of the board).
- Adjust the HVM potentiometer to manually adjust the high voltage to 800 Vdc. Place shunt back to the automatic side (inside two [2] pins).
- Set the LCD count time for 0.1 minute (6 seconds). Adjust the pulser count rate to 400,000 cpm and pulse amplitude to 20 mV. Press the COUNT button. When count cycle is complete, multiply the β BETA LCD reading by 10 and confirm that this reading is within $\pm 2\%$ of the incoming count rate. Repeat this step with 200 mV pulses and check the α -ALPHA LCD reading.
- The objective of the next steps is to find an operating voltage for the detector that will yield the detector's stated efficiency while not over-counting the background radiation field. The 2π efficiency (Eff) is calculated as:

$$\frac{\text{Instrument Count Rate}}{\text{cpm of Source}} \times 100\% = \text{Eff}$$

In addition, "cross talk" must be considered for determining the optimum operating voltage and is defined as:

$$\text{Alpha "cross talk"} = \frac{\alpha \text{Source} C_{\beta} - \text{Back} C_{\beta}}{\alpha \text{Net} C_{\alpha}} \times 100\%$$

and

$$\text{Beta "cross talk"} = \frac{\beta \text{Source} C_{\alpha} - \text{Back} C_{\alpha}}{\beta \text{Net} C_{\beta}} \times 100\%$$

where

$\alpha \text{Source} C_{\beta}$ = α source count in β channel

$\text{Back} C_{\beta}$ = background count in β channel

$\alpha\text{NetC}\alpha$ = Net α source count in α channel
 $\beta\text{SourceC}\alpha$ = β source count in α channel
 $\text{BackC}\alpha$ = background count in α channel
 $\beta\text{NetC}\beta$ = Net β source count in β channel

- For the alpha/beta scintillation detector, applicable 4π efficiencies are:

27% for ^{99}Tc ,

37% for ^{239}Pu .

- Acceptable background count rates (in a $10\mu\text{R/hr}$ field) are:

alpha: 3 cpm or less

beta: typically 50 cpm or less

(Model 3030E with 43-10-1: 50-80 cpm)

- Acceptable “crosstalk” values (in a $10\mu\text{R/hr}$ field) are:

alpha “crosstalk”: 10% or less

beta “crosstalk”: 1% or less.

- Using the computer interface software, perform a high voltage plateau in 25-volt increments from about 500 to 650 Vdc. Print the results and keep the printout with the calibration certificate.
- Find the optimum operating voltage, which gives the greatest alpha and beta source efficiencies and acceptable background (cpm), while maintaining acceptable values for “crosstalk” between channels.
- Set the unit in DPM mode with efficiencies, background subtract, and crosstalk correction numbers from the high voltage plateau.

- Set the count time to one minute and print out an MDA chart from the interface software.

Note:

The detector operating voltage must be determined and set before the overload (OL) adjustment is performed. If the detector operating voltage is readjusted, the OL setting must be readjusted.

- Adjust the OL control to the maximum counterclockwise position.
- To simulate a light leak, expose the photomultiplier tube (PMT) to light by pulling the tray out. Adjust the OL control until the overload LED just begins to flicker. Confirm that the overload LED turns off when the tray is latched closed.

Maintenance

Instrument maintenance consists of keeping the instrument clean and periodically checking the battery and calibration.

An instrument QC Check should be performed prior to each use by exposing the detector to a known source and confirming the proper reading on each scale.

Recalibration should be accomplished after any maintenance or adjustment has been performed on the instrument. Ludlum Measurements recommends recalibration at intervals no greater than one year. Local regulations may have precedence over this recommendation.

To maintain the life of the internal battery it is recommended that the instrument be constantly connected to line power with the power switch in the ON position, even when the instrument is not in use. This will keep the internal battery fully charged.

When the instrument is used without line power, adequate charge time must be allowed for the internal battery to recharge. If possible, leave the instrument on with line power applied overnight and weekends. At a minimum, allow one hour of charge time for each hour of use. If the battery is inadvertently allowed to fully discharge, and is left in that state, constant charging for 500 hours (three weeks) may be required for battery recovery.

Note:

The ON-OFF switch must be in the ON position to charge the batteries. If the unit is out of service for extended periods of time, charge the battery every six months.

It is recommended that the internal gel-cell battery be replaced every four years.

Section 7

Computer Software

The Model 3030 Control Software allows the user to set all parameters, view QC Check settings, run high voltage plateaus, perform MDA (Minimum Detectable Activity), and retrieve the sample data saved to the logging memory. Certain parameters can be protected by a password to prevent changes that could affect the calibration of the instrument.

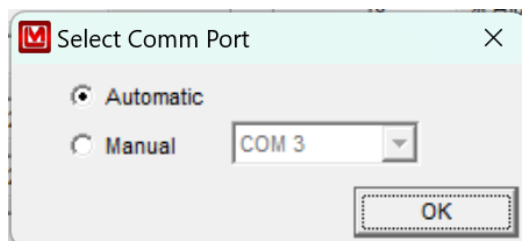

When the software is started, a dialogue is displayed allowing the user to manually select the Comm port or to have the software select it automatically. The software will only search Comm ports 1-16. After the Model 3030 is found, the parameters are downloaded from the instrument and the main screen is displayed. The main screen consists of a tabbed interface separating the various functions and includes General Settings, QC Check, HV Plateau, MDA Calculation, and Data Logging.

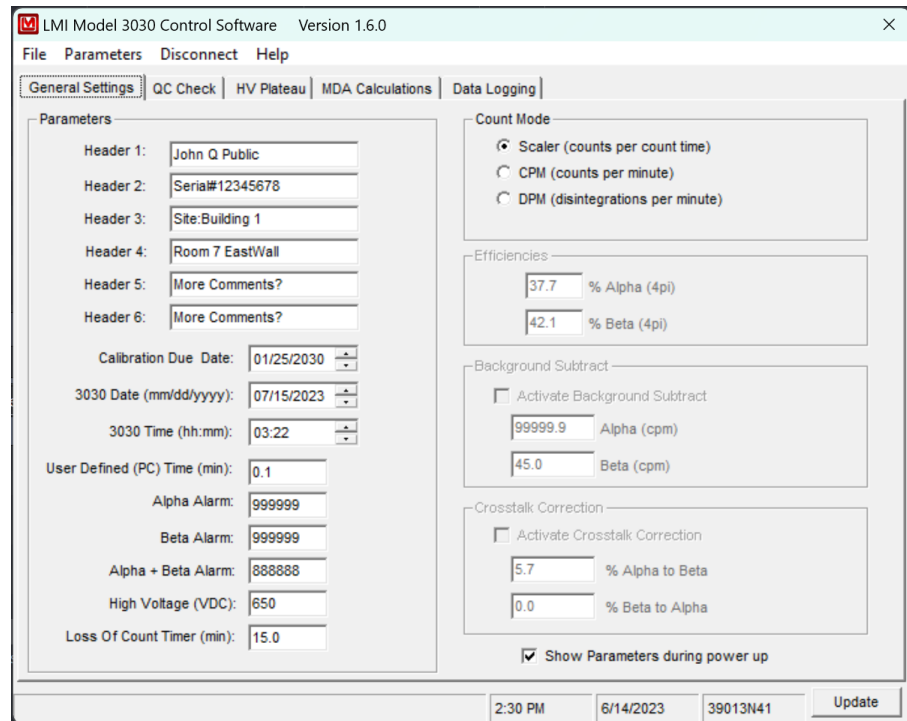

The following parameters require a password: Calibration Date, Date, Time, High Voltage, Background Subtract On/Off, Alpha Background Subtract, Beta Background Subtract, Alpha Efficiency, Beta Efficiency, Crosstalk On/Off, Alpha Crosstalk, and Beta Crosstalk. Running an HV Plateau is also password protected.

Password operation can be enabled in the Parameters menu. Selecting the "Password Protect" menu item will enable password protection. A checkmark next to this menu item will indicate if password protection is on or off. The password is required to change this.

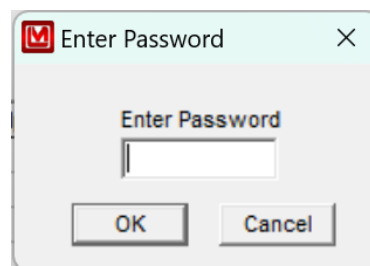

The default password is blank until it is changed by the user using the Change Password menu item. The password can contain the following characters: a-z, A-Z, 0-1, !@#\$\$%^&*() and cannot exceed eight characters in length.

The user is prompted for the password when clicking in the Update button after changing any of the password protected parameters. If the password given is correct, the parameters are changed and the instrument is updated. If the password is incorrect and the user cancels the password prompt, the previous values for the parameters are restored, with no parameters sent to the instrument. Clicking in the Start button under the HV Plateau tab will prompt the user for the password. The password will not be asked for again until a different tab is selected to allow the user to run multiple plateaus without having to enter the password every time.

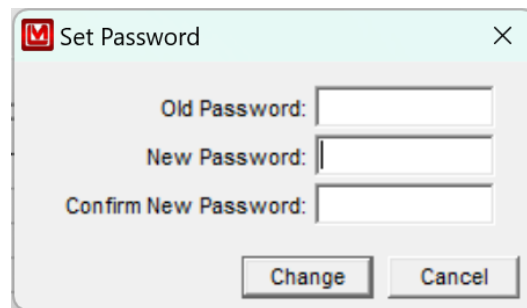

Parameters

The “Update” button at the bottom of the window will save all changes to the instrument.

File Menu/Load Defaults: This menu item loads the file, “default.cfg,” and saves the settings to the instrument.

Update	Ctrl+U
Load from File	Ctrl+O
Save to File	Ctrl+S
Reload All Data	Ctrl+R
Print Parameters	Ctrl+P

Parameters/Update (Ctrl-U): This menu item is the same as clicking on the “Update” button.

Parameters/Load from File (Ctrl-O): This menu item loads in settings from a user-defined text file.

Parameters/Save to File (Ctrl-S): This menu item will save the current settings to a user-defined file.

Parameters/Reload All Data (Ctrl-R): This menu item will reload all data from the instrument.

Parameters/Print Parameters (Ctrl-P): This menu item will print out a report of all parameters to a printer.

Parameters/Password Protect: When this is checked, certain functions require a password.

Parameters/Change Password: This selection changes the current password.

Headers 1-6: These are six user-defined fields to place general information. These are limited to 15 characters.

Calibration Due Date: This date is checked when instrument is turned on. If current date is past this date, “OUTCAL” is displayed on the instrument. Setting Dipswitch 2 to the “ON” position will disable this feature.

3030 Date/Time: This is the current date and time from the last time data was read from the instrument.

User Defined Time (min): In addition to the seven preset count times, there is a user-defined count time that can be set from the PC. This is the count time that will be used when the instrument is switched to the “PC” position.

Alpha, Beta, Alpha + Beta Alarms: These are the alarm settings. A value of 999999 will disable the alarm. If the unit is in CPM, the alarms are in CPM. If the instrument is in DPM, the alarms are in DPM. It is up to the user to make sure that the alarms are set accordingly to the count mode.

High Voltage: This field displays the current high-voltage setting. The high voltage may be adjusted from 0 to 2000 Vdc.

Loss of Count Timer: If the detector receives no counts on the beta channel after the time expires, the display will show “LOC FAIL” and will not operate until reset. This timer is reset whenever a count is received.

Count Mode: The model 3030 can display the readings in raw scaler counts, CPM, or DPM. If dipswitch 1 is “OFF,” the unit is always in scaler mode.

The Ludlum Model 3030 can operate as a traditional radiation scaler, displaying measurements in terms of CPM (counts per minute). It can also be programmed to automatically adjust and display the measurements in DPM (disintegrations per minute). By knowing what the efficiency is for alpha and beta particles, the Model 3030 is able to divide measurements by the known efficiency and display in DPM. The DPM mode may be easier for users, since many regulations and limits are expressed in terms of DPM.

In raw scaler mode, the count obtained is the actual counts received during that count time. In CPM mode, the counts are adjusted for the count time. In DPM mode, the counts are adjusted for count time and efficiency. For example:

$$\text{Count Time} = 0.1 \text{ minutes (6 seconds)}$$

Efficiency = 25%

Input = 1000 DPM

CPM = 250 counts per minute (no background subtract or crosstalk calculations)

DPM = 1000 disintegrations per minute (no background subtract or crosstalk calculations)

Alpha/Beta Efficiency: These values are only available when unit is in DPM count mode. This is used to calculate the DPM reading and is expressed as a percent. The QC mode has a function to update the efficiency with values calculated from the QC check.

Activate Background Subtract: This is only available when count mode is CPM or DPM. It turns on/off the background subtract and will subtract the background from each channel and display the net count.

Alpha/Beta Background Subtract: These values will be subtracted while the instrument is counting. For example, in CPM mode with an input of 2000 CPM and a background subtract value of 1000, the reading will display “1000.” The QC mode has a function to update the background subtract with values calculated from the QC check.

Activate Crosstalk Correction: This is only available when count mode is CPM or DPM. This control turns on/off the crosstalk correction.

% Alpha to Beta Crosstalk: This is the percent of alpha counts that are seen by the beta channel. Setting this number to 2% subtracts 2% of the received alpha counts from the beta channel.

% Beta to Alpha crosstalk: This is the percent of beta counts that are seen by the alpha channel. Setting this number to 2% subtracts 2% of the received beta counts from the alpha channel.

Show Parameters during power-up: When enabled, the following are displayed to the LCD display during power up: firmware version, date, time, high voltage, user-defined count time, and alarms.

QC Check

The screenshot shows the 'QC Check' window of the LMI Model 3030 Control Software, Version 1.6.0. The window has a menu bar with 'File', 'Parameters', 'Disconnect', and 'Help'. Below the menu bar are tabs for 'General Settings', 'QC Check', 'HV Plateau', 'MDA Calculations', and 'Data Logging'. The 'QC Check' tab is active.

QC Settings:

- Off
- Normal QC
- Background Update Only
- Manual QC Only
- Update Efficiency
- Update Background Subtract
- Override Count Time

Last QC Performed: 10/06/2022 10:53. A 'Reload Last Values' button is present.

Last QC Check:

- Last Alpha Efficiency (4pi) %: 39.7
- Last Alpha Background (cpm): 0.0
- Last Beta Efficiency (4pi) %: 41.7
- Last Beta Background (cpm): 99999.9

QC Parameters:

- Standard Alpha Efficiency (4pi) %: 38
- Standard Beta Efficiency (4pi) %: 13
- Allowable QC Efficiency ± %: 15
- Allowable QC Efficiency ± %: 15
- Alpha Background Limit Upper (cpm): 99999
- Beta Background Limit Upper (cpm): 50.0
- Lower (cpm): 0.0
- Lower (cpm): 0.0

Source Sizes:

	DPM	Bq	µCi	Alpha QC Source Count Time (min):	Beta QC Source Count Time (min):	Background QC Count Time (min):
Alpha Source Size:	21000	350.00	0.00945945946	1.0	1.0	1.0
Beta Source Size:	10394	173.23	0.00468198198			

At the bottom right, there is a status bar showing '2:30 PM', '6/14/2023', '39013N41', and an 'Update' button.

The Ludlum Model 3030 has a “QC Check” function that allows the user to determine whether the instrument is operating within predetermined limits. This function is optional and does not have to be enabled. There is also an option to update the background every 24 hours. This background update does not validate the received reading with any of the limits set on this screen. It simply takes a background count and stores that reading in the instrument. When the QC check is enabled, every day the user must perform the QC check procedure and receive acceptable values in order to utilize the instrument for normal use. After 24 hours, the instrument will light the red indicator marked “QC,” and not allow normal use until the next QC check. The predetermined limits are:

1. The instrument counts a specific alpha source with a known activity and receives a specified standard efficiency, plus or minus a specified percentage.
2. The instrument counts a specific beta source with a known activity and receives a specified standard efficiency, plus or minus a specified percentage.
3. The instrument counts background (no source inside the tray) and receives results that are within the upper and lower limits specified.

QC Off/Normal QC/Background Update Only/Manual QC Only: If enabled, 24 hours after the last QC check, the QC LED turns on and a QC check must be run before the normal operation can resume. The “Normal QC” check takes both an alpha and beta source count and a background count. The “Background Update Only” takes only background counts and replaces the current background subtract values with the new values. In the “Background Update Only” mode the display shows the counts in CPM with one decimal place. Manual mode allows the QC button to start a QC test but does not automatically require one after 24 hours. Manual QC option only available with firmware 39013N31 or higher.

If the QC mode is disabled then a QC test cannot be started with the QC button.

Update Efficiency: If enabled, the efficiencies calculated during the QC check will replace the efficiencies used for the DPM calculation. This option is only available in the Normal QC check mode.

Update Background Subtract: If enabled, the background readings received during the QC check will replace the current background subtract values. This option is only available in the Normal and Background Only QC check modes.

Override Count Time: If enabled, the count times set by the count time switch on the front of the instrument are overridden using the values in the alpha, beta, and background QC count times.

Last QC Performed: This is the last date and time a successful QC check was performed.

Last Alpha/Beta Efficiency: The last time a QC check was run, this was the computed efficiency.

Standard Alpha/Beta Efficiency: These are the values that the QC check will use to determine pass/fail. If the calculated efficiency is outside the Standard Efficiency by the Allowable QC Efficiency %, the QC will fail.

Allowable QC Efficiency \pm %: This is the range for how close the computed efficiency must be to the standard. A standard of 25% with an allowable range of 5% specifies that to pass the QC check, the efficiency must be in the range of 20% to 30% to pass.

Source Size: The DPM value of the source size is saved to the instrument and is used to determine the efficiency during a QC check.

Alpha QC Source Count Time (min): This is the alpha source count time in minutes used when the Override Count Time function is enabled.

Beta QC Source Count Time (min): This is the beta source count time in minutes used when the Override Count Time function is enabled.

Background QC Count Time (min): This is the background count time in minutes used when the Override Count Time function is enabled.

Alpha/Beta Upper & Lower Limits: These determine what range is acceptable for the background during a QC check. If the background does not fall within these values, the QC check will fail.

Alpha/Beta Upper & Lower Limits: These determine what range is acceptable for the background during a QC check. If the background does not fall within these values, the QC check will fail.

Steps for Performing a QC Check

1. To enable the QC mode, click on the box marked “Normal QC” in the tab marked “QC Settings.”
2. Press the button marked “Reload Last Values” at the bottom of the screen to see the last values calculated during the last HV Plateau. The data shown include the “Last QC Performed,” the “Last Alpha Efficiency,” the “Last Beta Efficiency,” the “Last Alpha Background,” and the “Last Beta Background.” These numbers are shown for reference ONLY. The QC check predetermined limits must be chosen and input by the user.
3. Enter values for the “Standard Alpha Efficiency” and the “Standard Beta Efficiency.” The values input here should reflect the average efficiency with the given sources. After entering the values, press the “Update” button.
4. Enter values for the “Allowable QC Efficiency.” These percentage values entered allow the instrument to accept efficiencies that are somewhat higher and lower than the standard efficiency. For example, if the standard alpha efficiency is 25% and the allowable QC efficiency is 5%, the acceptable alpha efficiency will be from 20% to 30%. After entering the values, press the “Update” button.
5. Enter the “Alpha Source Size” and “Beta Source Size” of the sources to be used during the QC check. It is preferred to use the DPM or μCi column wherever possible. Conversion from

CPM to DPM using a factor of 2 may not be correct, depending on isotope and source material. Note that these source sizes are completely independent of the source sizes used in the HV plateau. After entering the values, press the “Update” button.

Enter in upper and lower background limits for both alpha and beta background. Since alpha background is usually very low, it is acceptable to use a lower limit of 0. After entering the values, press the “Update” button.

To start a QC check:

1. Press the QC CHECK button on the front of the Model 3030. The Model 3030 does not need to be connected to a computer for the QC check to function.
2. If the Normal QC mode is selected, the upper LCD should flash ALPHA. Unlatch the tray and insert the alpha source. Close and latch the tray.
3. Press the COUNT button to start the alpha count. At the end of the count, the LCD will flash between displaying the final readings and ALPHA. If the QC Check fails, the instrument should be taken out of service until it can be repaired.
4. Unlatch the tray and remove the alpha source. Insert the beta source and close and latch the tray.
5. Press the COUNT button to advance to the beta step. The lower LCD should now flash BETA.
6. Press the COUNT button to start the beta count. At the end of the count the LCD will flash between displaying the final readings and BETA. If the QC check fails, the instrument should be taken out of service until it can be repaired.
7. Unlatch the tray and remove the beta source. Close and latch the tray.
8. Press the COUNT button to advance to the background count. Both displays should flash BAC.
9. Press the COUNT button to start the background count. At the end of the count, the LCD will flash between the readings and BAC. If the QC check fails, the instrument should be taken out of service until it can be repaired.

3. When all the parameters have been downloaded, click on the tab marked “HV Plateau” at the top of the window.
4. Enter the “Starting High Voltage” and the “Ending High Voltage.” These parameters define where the plateau will start and end.
5. Enter the “High Voltage Step.” This parameter determines the increment between steps in the plateau.
6. Enter the “Alpha Source Size” and “Beta Source Size.” There are three fields for each channel corresponding to CPM, DPM, and μCi . The user can enter the source size in any field, and the other fields will automatically show the converted value. It is preferred to use the DPM or μCi column wherever possible. Conversion from CPM to DPM using a factor of 2 may not be correct depending on isotope and source material. Under the “ISOTOPE” fields, enter the isotope label for the alpha and beta source.
7. Verify the current count time. The Model 3030 has seven preset time values and a user-definable “PC” time set by the computer. The “PC” time is defined in the tab marked “General Settings.” Enter in the needed time and press “Update.” If a different time is required, change the time by using the knob on the front of the instrument and click the “Read” button to refresh the count time on screen. The background count time is always one minute.
8. Press the “Start” button to start the plateau. There is a prompt to insert the alpha source. The Model 3030 will record readings at each high voltage as determined above. When the alpha plateau is completed, you are prompted to insert the beta source. Again, the Model 3030 will record readings at each high voltage. After the beta plateau is complete, you are prompted to remove the beta source. Background counts are then taken. The grid contains the following columns:
 1. Alpha source (beta counts shown in parenthesis)
 2. Beta source (alpha counts shown in parenthesis)
 3. Alpha background in cpm
 4. Beta background in cpm
 5. % alpha efficiency (4π)

6. % beta efficiency (4π)
7. % alpha to beta crosstalk
8. % beta to alpha crosstalk
9. After the plateau is complete, you can either save the plateau to an ASCII text file or print the results for later reference.
10. You may choose the operating voltage according to your own standards. Ludlum Measurements current standards, which may or may not be appropriate for your use, are listed below:
 - (a) ^{99}Tc efficiency (4π) greater than or equal to 27%
 - (b) ^{239}Pu efficiency (4π) greater than or equal to 37%
 - (c) Alpha crosstalk in beta channel less than or equal to 10%
 - (d) Beta crosstalk in alpha channel less than or equal to 1%
 - (e) Beta background is less than or equal to 50 cpm
 - (f) Alpha background is less than or equal to 3 cpm
11. By double-clicking on a row after the plateau has completed, the user may automatically update the efficiencies, background subtract, and crosstalk values, or the user can manually enter in the values to update the instrument.

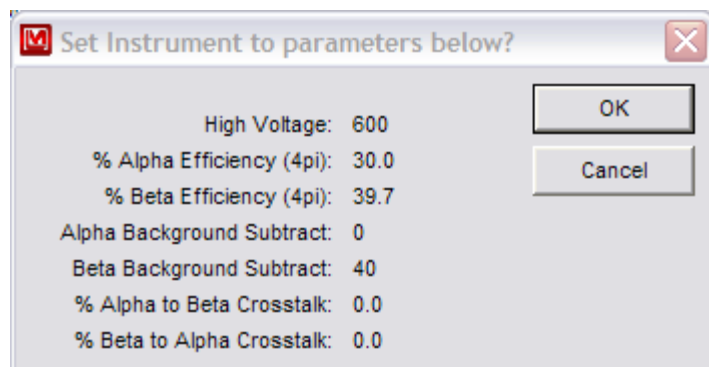
**Manual Entry:**

12. Enter the selected operating voltage in the field marked "High Voltage (Vdc)" and click "Update." This action stores the chosen operating voltage inside the Model 3030.

13. Click on “DPM” under the Count Mode area to select DPM mode.
14. Enter in the alpha and beta efficiencies as 4π efficiencies and click “Update.”
15. You may also choose to utilize the “Background Subtract” function by entering values to subtract the known constant background from each measurement. The values may be chosen from the data gathered above during the plateau. When used, the value entered is subtracted prior to the conversion to DPM.
16. You may also choose to utilize the “Crosstalk Correction” function by entering values to correct each measurement for crosstalk. The values may be chosen from the data gathered above during the plateau. When used, the crosstalk correction is applied to measurements after background subtraction (if active) and before the DPM conversion (if active).

MDA Calculations

LMI Model 3030 Control Software Version 1.6.0

File Parameters Disconnect Help

General Settings | QC Check | HV Plateau | **MDA Calculations** | Data Logging

Alpha Background (cpm): 99999.9 Alpha Efficiency (%): 37.7

Beta Background (cpm): 45.0 Beta Efficiency (%): 42.1

Print

Background Count Time (Minutes)

0.1 Update

Count Time (min)	Alpha MDA (dpm)	Beta MDA (dpm)
0.1	12413.4	298.8
0.5	9574.1	194.5
1.0	9159.9	180.3
2.0	8945.9	173.1
5.0	8815.1	168.7
10.0	8771.0	167.2
60.0	8734.2	166.0
PC (0.1)	12413.4	298.8

Formula

$$\text{MDA(dpm)} = \frac{2.71 + \text{CL} * \text{SQRT}(\text{Background} * \text{Ts} * (1 + (\text{Ts} / \text{Tb})))}{\text{E} * \text{Ts}}$$

Tb = Background Count Time (min) Select Confidence Level

Ts = Source Count Time (min) 90% = 2.5632

E = Counter Efficiency 95% = 3.290

CL = Confidence Level 99% = 4.6526

2:30 PM 6/14/2023 39013N41 Update

This screen shows the calculated MDA values for all count times based on the current background and efficiency values. The confidence level may be set at 90%, 95%, or 99%. This screen is only available when the instrument is in DPM mode. The values are preset according to the current instrument settings but may be changed here. The data may also be printed to a printer.

Data Logging

LMI Model 3030 Control Software Version 1.6.0

File Parameters Disconnect Help

General Settings QC Check HV Plateau MDA Calculations Data Logging

Start Count Stop Count

Next Sample Number: FULL

User-defined comment: AAAAAAAAAA

Logging Mode: Log QC Only

Recycle On

Printer Mode On

Get Samples Clear Samples

Sample #	Date	Time	Alpha Count	Beta Count	Count Time	Type	Comment

Save Samples Save CSV Print Samples

2:31 PM 6/14/2023 39013N41 Update

The Model 3030 can store 600 samples in its data logging memory. The following fields are stored with each sample: time, date, alpha reading, beta reading, count time, count mode, and user-defined comment.

Recycle On: This will activate the recycle function. As soon as the count completes, another one is started automatically.

Logging Mode: The choices are either Off, Log All, or Log QC only. This will activate the saving of samples to the instrument's non-volatile memory.

Printer Mode On: When activated, the instrument will output the count data to the serial port. No handshaking is active. A serial printer may be connected to display the data. The date, time, alpha reading, beta reading, count mode, and count time is output. The count mode is indicated by a single letter: C = cpm, D = dpm, S = Scaler.

Get Samples: This button reads all sample data from the instrument.

Clear Samples: This button clears the instrument of all samples in memory.

Save Samples: This allows saving the sample data to a user-defined file. The data is saved in a comma delimited (*.csv) file to allow for importing into other applications.

Print Samples: Selecting this option prints the sample data to a printer.

RS-232 Communication

The Model 3030 communicates by way of an RS-232 interface. The RS-232 port operates at 9600 baud, 8 data bits, 1 stop bit, no parity, and hardware (RTS/CTS) flow control.

A standard RS-232 cable with straight-through connections is required.

Following is information for pin-outs of the RS-232 Connector/Cable:

<u>M3030</u>		<u>PC (9-Pin)</u>	
2	TXD	RXD	2
3	RXD	TXD	3
5	GND	GND	5
7	CTS	RTS	7
8	RTS	CTS	8

The Model 3030 uses the line-feed character [LF] to terminate commands. It is acceptable to terminate commands with a carriage return and a line feed character. All messages received from the Model 3030 are terminated with a carriage return and line feed character.

The commands are not case sensitive. Any command not recognized will return "ERROR-xx" where xx is the first two characters of the unknown command.

[LF] = line feed character (ASCII value 10)

[CR] = carriage return character (ASCII value 13)

COMMANDS

Bn – Background Subtract Status

Sets background subtract ON/OFF or return background subtract status, where “n: is a value of 0, 1, or 2.

0 = Sets background subtract OFF.

1 = Sets background subtract ON.

2 = Returns status.

Cn - Count

Performs various count functions. The count time is determined by the positioning of the COUNT TIME SWITCH on the front panel unless otherwise noted. See command RR for the format of the count results.

- 1 = Start a count.
- 2 = Stop a count in progress.
- 3 = Clear alarms.
- 4 = Start a count and automatically return the results.
- 5 = Start a one-minute count and automatically return the results.

Dn – Display Mode

The display can be set to show count data as raw scaler counters, counts per minute (CPM), and disintegrations per minute (DPM).

- 0 = Set display mode to scaler.
- 1 = Set display mode to CPM.
- 2 = Set display Mode to DPM.
- 3 = Return display mode (SCA, CPM, or DPM).

F – Firmware

Returns a string containing the firmware version number.

Ln – Logging Mode

Sets how samples are logged to internal memory.

- 0 = Turn logging OFF.
- 1 = Turn Logging ON.
- 2 = Log only QC checks.
- 3 = Return logging mode (OFF, ON, or QC).

Pn

Sets printer mode On/Off.

- 0 = Turn printing OFF.
- 1 = Turn printing ON.
- 2 = Return printing mode (OFF, ON).

Qx

Sets quick power-on mode. The Model 3030 may be configured to display certain parameters during power-up.

- 0 = Show parameters OFF.
- 1 = Show parameters ON.
- 2 = Return power-up mode (OFF, ON).

RA – Read Next Sample Number

Reads the next sample number. Subtracts one from this number to get the total number of samples logged. Returns nnnn.

RBn – Read Background Subtract

Reads the alpha or beta background subtract value. The value returned must be divided by 10 to get the correct value. Returns nnnnnn.

1 = Read alpha background subtract.

2 = Read beta background subtract.

RC – Read Calibration Due Date

Reads the calibration due date. Returns MMDDYYYY.

RD – Read Current Date and time

Reads the current date and time. Returns HH:MM:SS MM/DD/YYYY.

REn – Read Efficiency

Reads the alpha or beta percent efficiency. The value returned must be divided by 10 to get the correct value. Returns nnn.

1 = Read alpha percent efficiency.

2 = Read beta percent efficiency.

RHn – Read Header

Reads the 15-character, user-definable header where “n” is a value from 1 to 6. Returns xxxxxxxxxxxxxxxx.

RL – Read Loss of Count Timer

Reads the loss of count timer value in seconds. Returns two lines. Line 1 contains the count time as nnnnn.n. Line 2 returns “BETA” if the loss of count timer has expired. Otherwise, “OK” is returned.

RNn – Read MDA

Reads the Minimum Detectable Activity (MDA). Returns nnnnnn.

1 = Read alpha ratemeter MDA.

2 = Read beta ratemeter MDA.

3 = Read alpha scaler MDA.

4 = Read beta scaler MDA.

RP – Read the PC Time

Reads the PC or user-defined count time in seconds. The PC time is used when the COUNT TIME SWITCH on the front panel is set to PC. Returns nnnnn.n.

RQn

Reads the specified QC parameter.

- 01 = Read QC enabled status. Returns ON or OFF.
- 02 = Read current alpha efficiency %. Returns nn.
- 03 = Read current beta efficiency %. Returns nn.
- 04 = Read standard alpha efficiency %. Returns nn.
- 05 = Read standard beta efficiency %. Returns nn.
- 06 = Read alpha source size (cpm). Returns nnnnnn.
- 07 = Read beta source size (cpm). Returns nnnnnn.
- 08 = Read alpha efficiency limit %. Returns nn.
- 09 = Read beta efficiency limit %. Returns nn.
- 10 = Read alpha background upper limit (cpm). Returns nnnnnn.
- 11 = Read alpha background lower limit (cpm). Returns nnnnnn.
- 12 = Read beta background upper limit (cpm). Returns nnnnnn.
- 13 = Read beta background lower limit (cpm). Returns nnnnnn.
- 14 = Read last QC date. Returns MM/DD/YYYY.
- 15 = Read alpha background (cpm). Returns nnnnnn.
- 16 = Read beta background (cpm). Returns nnnnnn.
- 17 = Read last QC time. Returns HH:MM.
- 18 = Read QC Mode. Returns NOR, BKG, or MAN.
- 19 = Read QC Update Mode. Returns OFF, ON, EFF, or SUB.
- 20 = Read alpha source count time (secs). Returns nnnnn.n.
- 21 = Read beta source count time (secs). Returns nnnnn.n.
- 22 = Read background count time (secs). Returns nnnnn.n.
- 23 = Read QC override status. Returns OFF or ON.

RR – Read Count

Reads the current alpha and beta counts. Returns HH:MM MM/DD/YY
aaaaaa bbbbbb x tttt.t.

aaaaaa = alpha count

bbbbbb = beta count

x = S (scaler), C (cpm), and D (dpm)

tttt.t = count time in minutes (If count is in progress, this value shows count time remaining.)

RS – Read Samples

Reads all logged samples from memory. While reading samples, the audio is stopped and the displays show a scrolling series of dashes along with the sample number. A "\$" marks the end of the samples.

Returns: ssss MM/DD/YY HH:MM:SS aaaaaa bbbbbb tttt.t x
cccccccc[CR][LF] - 59 bytes \${CR}[LF] - 3 bytes

ssss = sample number
aaaaaa = alpha scaler
bbbbbb = beta scaler
x = S (Scaler), C (cpm), and D (dpm)
tttt.t = count time in seconds
cccccccc = user defined comment

RT – Read Current Count Time

Reads the current count time in seconds. Returns nnnnn.n.

RU – Read Comment

Reads the user-defined, 10-character comment field. Returns xxxxxxxxxx.

RV – Read High Voltage

Reads the high voltage set point. Returns nnnn.

RXn – Read the Crosstalk

Reads the beta-to-alpha or alpha-to-beta crosstalk. The value must be divided by 10 to get the correct value. Returns nnn.

1 = Read beta-to-alpha crosstalk.
2 = Read alpha-to-beta crosstalk.

RY – Read Recycle Mode Status

Reads the status of the recycle mode. Returns OFF or ON.

Rn – Read the Alarm Set Points

Reads the specified alarm set point. Returns nnnnnn.

1 = Read alpha alarm set point.
2 = Read beta alarm set point.
3 = Read alpha + beta alarm set point.

Xn – Set Crosstalk Mode

Sets crosstalk ON/OFF or return crosstalk status, where “n” is a value of 0, 1, or 2.

0 = Sets crosstalk OFF.
1 = Sets crosstalk ON.
2 = Returns status.

SBnxxxxxx – Set Background Subtract

Sets the alpha or beta background subtract.

1 = Set alpha background subtract.
2 = Set beta background subtract.

SCmmdyyy – Set Calibration Date

Sets the calibration due date.

SDmmdyyy – Set Date

Sets the date on the read time clock. The “z” is the value of the year Mod 4.

SEnxxx – Set Efficiency

Sets the alpha or beta efficiency. The efficiency must be multiplied by 10 before sending.

1 = Set alpha efficiency.

2 = Set beta efficiency.

SHxxxxxxxxxxxxxxxx – Set Header

Sets a user-defined header. There are six headers accessed 1-6. Each header is 15 characters long.

SLyyyyy.y – Set Loss of Count Timer

Sets the loss of count timer in seconds. The max is 99999.9 seconds.

SNnyyyyyy – Set MDA

Sets the alpha and beta MDA.

1 = Set alpha MDA.

2 = Set beta MDA.

SPxxxxx.x

Sets the user-defined count time when the COUNT TIME SWITCH is in the “PC” position. The max is 99999.9 seconds.

SQnn – Set QC parameters

Sets the specified QC parameter.

01 = Set QC enabled status. 0 = OFF, 1 = ON.

04 = Set standard alpha efficiency %. Format ##.

05 = Set standard beta efficiency %. Format ##.

06 = Set alpha source size (cpm). Format #####.

07 = Set beta source size (cpm). Format #####.

08 = Set alpha efficiency limit %. Format ##.

09 = Set beta efficiency limit %. Format ##.

10 = Set alpha background upper limit (cpm). Format #####.

11 = Set alpha background lower limit (cpm). Format #####.

12 = Set beta background upper limit (cpm). Format #####.

13 = Set beta background lower limit (cpm). Format #####.

17 = Set last QC time. Format HHMM.

18 = Set QC Mode. 0 = NOR, 1 = BKG, 2=MAN.

- 19 = Set QC Update Mode. 0 = OFF, 1 = ON, 2 = EFF, 3 = SUB.
- 20 = Set alpha source count time (secs). Format #####.#.
- 21 = Set beta source count time (secs). Format #####.#.
- 22 = Set background count time (secs). Format #####.#.
- 23 = Set QC override status. 0 = OFF, 1 = ON.

SR – Reset All Samples

Clears all logged samples from memory.

SThhmm – Set Time

Sets the real-time clock. Seconds are always started at 00.

SUxxxxxxxx – Set Command

Sets a user-defined, 10-character comment that is saved with the logged samples.

SVxxxx – Set High Voltage

Sets high voltage from 0000 to 2000 volts.

SXnyyy – Set Crosstalk

Sets the beta-to-alpha or alpha-to-beta crosstalk. The crosstalk must be multiplied by 10 before sending.

- 1 = Set beta to alpha crosstalk.
- 2 = Set alpha to beta crosstalk.

SYn – Set Recycle Mode

Set recycle mode. If recycle mode is ON, after a count completes, another one will be started automatically.

- 0 = Set recycle mode OFF.
- 2 = Set recycle mode ON.

Snxxxxxx – Set Alarm

Set the specified alarm set point.

- 1 = Set alpha alarm set point.
- 2 = Set beta alarm set point.
- 3 = Set alpha + beta alarm set point.

Sample Printouts

Ludlum Measurements, Inc.
 Model 3030 Plateau Data

 01/15/2001
 10:05:07 AM

Header 1: John Q Public
 Header 2: Serial#12345678
 Header 3: Site:Building 1
 Header 4: Room 7 EastWall
 Header 5: More Comments?
 Header 6: More Comments?

Calibration Due Date: 12/31/2010

Model 3030 Date: 01/15/2001
 Model 3030 Time: 09:00:08

User PC Time: 0001.0

Alpha Isotope: ²³⁹Pu
 Alpha Source Size (cpm): 15450
 Alpha Source Size (dpm): 30900
 Alpha Source Size (µCi): 0.013918919

Beta Isotope: ⁹⁹Tc
 Beta Source Size (cpm): 9350
 Beta Source Size (dpm): 18700
 Beta Source Size (µCi): 0.008423423

Starting High Voltage: 750
 Starting High Voltage: 950
 High Voltage Increment: 25

Source Count Time (min): 0001.0
 Background Count Time (min): 1.0
 Plateau Count Mode: SCALER

HV	ALPHA					BETA				
	Source	(Beta)	Background	Eff	CrossTalk	Source (Alpha)	Background	Eff	Crosstalk	
750	11474	(764)	0	37.1%	6.4%	3868	(3)	35	20.5%	0.1%
775	11613	(533)	0	37.6%	4.3%	4128	(1)	36	21.9%	0.0%
800	11940	(469)	0	38.6%	3.6%	4523	(0)	43	24.0%	0.0%
825	11657	(377)	0	37.7%	2.8%	4753	(4)	50	25.1%	0.1%
850	11762	(322)	0	38.1%	2.3%	4969	(2)	51	26.3%	0.0%
875	11854	(335)	0	38.4%	2.1%	5009	(4)	81	26.4%	0.1%
900	11927	(338)	0	38.6%	1.4%	5066	(1)	167	26.2%	0.0%
925	11898	(390)	0	38.5%	0.0%	5285	(0)	477	25.7%	0.0%
950	11945	(493)	1	38.7%	0.0%	5501	(1)	1196	23.0%	0.0%

Ludlum Measurements, Inc.
 Model 3030 MDA Calculation Data

 01/15/2001
 11:05:07 AM

Alpha Background(cpm): 1
 Beta Background (cpm): 44

Alpha Efficiency %: 15

Beta Efficiency %: 25

Confidence Level: 90%

Count Time	Alpha MDA(dpm)	Beta MDA(dpm)
0.1	237.3	334.0
0.5	65.7	139.5
1	42.2	107.0
2	30.0	88.7
5	22.3	76.7
10	19.7	72.4
60	17.5	68.8

Ludlum Measurements, Inc.
Model 3030 Sample Data

01/15/2001
12:05:07 AM

Sample #	Date	Time	Alpha Count	Beta Count	Count Time	Type	Comment
001	01/15/2001	08:01:00	1	44	0001.0	s	
002	01/15/2001	08:02:00	0	38	0001.0	s	
003	01/15/2001	08:03:00	0	41	0001.0	s	
004	01/15/2001	08:04:00	1	42	0001.0	s	
005	04/17/2001	08:00:00	0	44	0001.0	s	QC Check
005	01/17/2001	08:02:00	0	38	0001.0	s	
006	01/17/2001	08:03:00	0	41	0001.0	s	
007	01/17/2001	08:04:00	1	42	0001.0	s	
008	04/18/2001	08:00:00	0	44	0001.0	s	QC Check
009	04/19/2001	08:00:00	0	40	0001.0	s	Bkgnd Upd

Software License Agreement



LUDLUM MEASUREMENTS, INC.
 501 OAK ST., P.O. BOX 810
 SWEETWATER, TX 79556
 325/235-5494 FAX: 325/235-4672

Software License Agreement

Rev. (number) 1.0

Written by (or Revised by):

Date: 20 Jan 06

Approved by:

Richard Spola
Ed Em

Date: 20 Jan 06

BY INSTALLING THIS SOFTWARE, YOU ARE CONSENTING TO BE BOUND BY THIS AGREEMENT. IF YOU DO NOT AGREE TO ALL OF THE TERMS OF THIS AGREEMENT, DO NOT INSTALL THE PRODUCT.

Single User License Grant: Ludlum Measurements, Inc. ("Ludlum") and its suppliers grant to Customer ("Customer") a nonexclusive and nontransferable license to use the Ludlum software ("Software") in object code form solely on a single central processing unit owned or leased by Customer or otherwise embedded in equipment provided by Ludlum.

Customer may make one (1) archival copy of the Software provided Customer affixes to such copy all copyright, confidentiality, and proprietary notices that appear on the original.

EXCEPT AS EXPRESSLY AUTHORIZED ABOVE, CUSTOMER SHALL NOT: COPY, IN WHOLE OR IN PART, SOFTWARE OR DOCUMENTATION; MODIFY THE SOFTWARE; REVERSE COMPILE OR REVERSE ASSEMBLE ALL OR ANY PORTION OF THE SOFTWARE; OR RENT, LEASE, DISTRIBUTE, SELL, OR CREATE DERIVATIVE WORKS OF THE SOFTWARE.

Customer agrees that aspects of the licensed materials, including the specific design and structure of individual programs, constitute trade secrets and/or copyrighted material of Ludlum. Customer agrees not to disclose, provide, or otherwise make available such trade secrets or copyrighted material in any form to any third party without the prior written consent of Ludlum. Customer agrees to implement reasonable security measures to protect such trade secrets and copyrighted material. Title to Software and documentation shall remain solely with Ludlum.

LIMITED WARRANTY. Ludlum warrants that for a period of ninety (90) days from the date of shipment from Ludlum: (i) the media on which the Software is furnished will be

free of defects in materials and workmanship under normal use; and (ii) the Software substantially conforms to its published specifications. Except for the foregoing, the Software is provided AS IS. This limited warranty extends only to Customer as the original licensee. Customer's exclusive remedy and the entire liability of Ludlum and its suppliers under this limited warranty will be, at Ludlum or its service center's option, repair, replacement, or refund of the Software if reported (or, upon request, returned) to the party supplying the Software to Customer. In no event does Ludlum warrant that the Software is error free or that Customer will be able to operate the Software without problems or interruptions.

This warranty does not apply if the software (a) has been altered, except by Ludlum, (b) has not been installed, operated, repaired, or maintained in accordance with instructions supplied by Ludlum, (c) has been subjected to abnormal physical or electrical stress, misuse, negligence, or accident, or (d) is used in ultrahazardous activities.

DISCLAIMER. EXCEPT AS SPECIFIED IN THIS WARRANTY, ALL EXPRESS OR IMPLIED CONDITIONS, REPRESENTATIONS, AND WARRANTIES INCLUDING, WITHOUT LIMITATION, ANY IMPLIED WARRANTY OF MERCHANTABILITY, FITNESS FOR A PARTICULAR PURPOSE, NONINFRINGEMENT OR ARISING FROM A COURSE OF DEALING, USAGE, OR TRADE PRACTICE, ARE HEREBY EXCLUDED TO THE EXTENT ALLOWED BY APPLICABLE LAW.

IN NO EVENT WILL LUDLUM OR ITS SUPPLIERS BE LIABLE FOR ANY LOST REVENUE, PROFIT, OR DATA, OR FOR SPECIAL, INDIRECT, CONSEQUENTIAL, INCIDENTAL, OR PUNITIVE DAMAGES HOWEVER CAUSED AND REGARDLESS OF THE THEORY OF LIABILITY ARISING OUT OF THE USE OF OR INABILITY TO USE THE SOFTWARE EVEN IF LUDLUM OR ITS SUPPLIERS HAVE BEEN ADVISED OF THE POSSIBILITY OF SUCH DAMAGES. In no event shall Ludlum's or its suppliers' liability to Customer, whether in contract, tort (including negligence), or otherwise, exceed the price paid by Customer. The foregoing limitations shall apply even if the above-stated warranty fails of its essential purpose. SOME STATES DO NOT ALLOW LIMITATION OR EXCLUSION OF LIABILITY FOR CONSEQUENTIAL OR INCIDENTAL DAMAGES.

The above warranty DOES NOT apply to any beta software, any software made available for testing or demonstration purposes, any temporary software modules or any software for which Ludlum does not receive a license fee. All such software products are provided AS IS without any warranty whatsoever.

This License is effective until terminated. Customer may terminate this License at any time by destroying all copies of Software including any documentation. This License will terminate immediately without notice from Ludlum if Customer fails to comply with any provision of this License. Upon termination, Customer must destroy all copies of Software.

Software, including technical data, is subject to U.S. export control laws, including the U.S. Export Administration Act and its associated regulations, and may be subject to export or import regulations in other countries. Customer agrees to comply strictly with

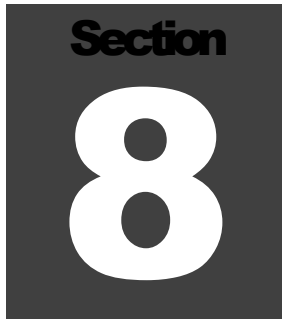
A dark gray square containing the word "Section" in a bold, sans-serif font at the top, and a large, white, bold number "8" in the center.

Software Changes

01/22/2001 1.0.6

Requires firmware 39013n05 or later

Added an update all, instead of separate update buttons

Added load/save parameters to txt file.

When reloading defaults, clear all samples, prompt first

Added new log mode "log qc checks only", save "QC" in comment

08/17/2001 1.0.8

Fixed problem with setting params (from grid), error 13 type mismatch. caused when grid fields were formatted with % sign. Just trim from value b4 trying to set parameters.

08/20/2001 1.0.9

Fixed problem with printparameters. was trying to print FrmMain.txtSourceSize(4 and 5).text which no longer exists, causing routine to run thru error trap and never exec printer.enddoc

01/28/2002 1.0.10

Added password control to general settings.

Resized grid columns when form is maximized.

02/12/2002 1.0.11

Fixed when logged data was "BKGND UPD " wasnt div by 10 in getsamples().

02/05/2003 1.0.12

Change printout, was typo using cpm, dpm when should be dpm, uCi.

03/06/2003 1.0.13

Fixed problem with calc uCi, used format function to format field. Was showing .0025 and sometimes 2.5 e-3.

Removed password check, doesnt really work right and dont know if its needed.

10/29/2003 1.1.0

Added password protection for hv, eff, crosstalk, cal due date, hv plateau

Added option to enable or disable password

11/20/2003 1.1.1

Fixed formatting of source sizes

06/29/2004 1.1.2

Fixed to allow software to find model 3030 on comm ports 1 - 16 instead of 1 - 4.

02/06/2006 1.2.0

Fixed problem where software would never finish downloading samples. Would get stuck at 99%.

04/25/2007 1.3.0

Added ability to manually or automatically select com ports like 2360.
Changed "Print Samples" report to include header, cal due, and last qc check information.

01/16/2008 1.4.0

Added support for firmware 39013n20

02/17/2009 1.4.1

Changed to use SAX comm component.
Fixed bug with downloading more than 66 logged samples.

05/26/2009 1.4.2

Added changed for LANL.

05/26/2009 1.4.3

Fixed problem where last sample was not saved to file or printed out.

06/23/2009 1.4.4

Fixed bug where Cross talk parameters were swapped when setting from the plateau grid.

07/01/2009 1.4.5

Bug fixes

10/05/2010 1.4.6

Fixed locale issues. Should work with , as the decimal separator now.
Fixed other minor issues.

11/16/2011 1.4.7

Increased time for allowing hv to stabilize during plateau. Board modification slows how fast the dac updates.

07/03/2012 1.4.8

Added save option to save logged samples as a text file rather than a csv file.

10/08/2012 1.4.9

Added support for the 3030-2. Four display modes (scaler, cpm, bq, cps).
Removed dependency on msstdfmt.dll. Was causing a run time error 713 on Windows 7.

08/20/2014 1.5.0

Fixed issue where logged data decimal would be off. This was caused by the addition of the 3030-2.

09/25/2014 1.5.1

Fixed issue where auto find would not find 3030 on com port under windows xp.
Changed so only available com ports are listed
Increased com search to 32 from 16.

01/14/2015 1.5.2

Changed max hv from 2000 to 2500. This was a special request for customer and the hardware may not be able to reach this hv.
NOT STANDARD RELEASE AND MAY BE DELETED IF HARDWARE DOESNT SUPPORT IT.

11/09/2015 1.5.3

Added manual QC option.
Added option to change order or plateau from alpha, beta, background to beta, alpha, background.
Fixed a couple of messages that were not requiring the correct number of return bytes.
Renamed PDF manual to make it easier for version control.
Fixes issue where cancel button on plateau asks if the plateau should be extended.
Fixes issue where extended plateau only populates the last row with the previous rows being empty.

12/04/2015 1.5.4

Fixed mda background time.
Fixed formatting of the qc alpha/beta source size.
Fixed bug with select case statement.

04/19/2027 1.5.5

Fixed issue with N16 firmware and the efficiency. Was waiting for 5 characters when firmware only sends 4 back.
Display error message when computer has no com ports rather than error 380.

04/27/2017 1.5.6

Fixed issue for 3030-2 where alarm set points didn't consider that the becquerel and cps modes had two decimal places.

02/17/2020 1.5.7

Fixed typo in the plateau data printout.

02/28/2020 1.5.8

Fixed issue where the last qc efficiency decimal place was off for the 3030-2.

04/19/2022 1.5.9

Fixed where cross talk percent on the save file or printout could crash while trying to format big numbers. Custgomer had a large 150400% alpha crosstalk which caused the program to crash out, so only the header would save/print.

Also changed to default filename of plateau isn't plateau..txt.

06/14/2023 **1.6.0**

Shifted the parameters printout 8 characters to the right.

06/15/2023 **1.6.1**

Shifted plateau and MDA printout 8 characters to the right.

Section
9

Recycling

Ludlum Measurements, Inc. supports the recycling of the electronic products it produces for the purpose of protecting the environment and to comply with all regional, national, and international agencies that promote economically and environmentally sustainable recycling systems. To this end, Ludlum Measurements, Inc. strives to supply the consumer of its goods with information regarding reuse and recycling of the many different types of materials used in its products. With many different agencies – public and private – involved in this pursuit, it becomes evident that a myriad of methods can be used in the process of recycling. Therefore, Ludlum Measurements, Inc. does not suggest one particular method over another, but simply desires to inform its consumers of the range of recyclable materials present in its products, so that the user will have flexibility in following all local and federal laws.

The following types of recyclable materials are present in Ludlum Measurements, Inc. electronic products and should be recycled separately. The list is not all-inclusive, nor does it suggest that all materials are present in each piece of equipment:

Batteries, Glass, Aluminum, and Stainless Steel

Circuit Boards, Plastics, Liquid Crystal Display (LCD)

Ludlum Measurements, Inc. products, which have been placed on the market after August 13, 2005, have been labeled with a symbol recognized internationally as the “crossed-out wheellie bin.” This notifies the consumer that the product is not to be mixed with unsorted municipal waste when discarding; each material must be separated. The symbol will be placed near the AC receptacle, except for portable equipment where it will be placed on the battery lid.

The symbol appears as such:



Section 10

Parts List

	<u>Reference</u>	<u>Description</u>	<u>Part Number</u>
Model 3030 & Model 3030E Alpha-Beta Sample Counters	UNIT	Completely Assembled Model 3030 Alpha-Beta Sample Counter	48-3204
	UNIT	Completely Assembled Model 3030E Alpha-Beta Sample Counter	48-3448
Amplifier / Processor Board, Drawing 337 × 365	BOARD	Completely Assembled Amplifier/Processor Board	5337-365
CRYSTALS	Y1	Micro 32.768 KHz	01-5305
	Y2	Micro 6.144 MHz	01-5262
CAPACITORS	C1-C4	1uF, 35V	04-5656
	C5	10uF, 10V	04-5757
	C6	10pF, 100V	04-5673
	C7-C8	27pF, 100V	04-5658
	C9	0.1uF, 50V	04-5663
	C10	1uF, 35V	04-5656
	C11	0.00u1F, 100V	04-5659
	C12	100pF, 100V	04-5661
	C13	0.001uF, 100V	04-5659
	C14	0.1uF, 50V	04-5663
	C15	47pF, 100V	04-5660
	C16	10uF, 25V	04-5655
	C17	47pF, 100V	04-5660
	C18	0.001uF, 100V	04-5659
	C19	0.01uF, 50V	04-5664
	C20	47pF, 100V	04-5660
	C21	0.1uF, 50V	04-5663
	C22	10pF, 100V	04-5673
	C23	47pF, 100V	04-5660

	<u>Reference</u>	<u>Description</u>	<u>Part Number</u>
	C24	100pF, 3KV	04-5532
	C25	47pF, 100V	04-5660
	C26	0.01uF, 50V	04-5664
	C27	47pF, 100V	04-5660
	C28	100pF, 3KV	04-5532
	C29	0.0047uF, 3KV	04-5547
	C30	0.1uF, 50V	04-5663
	C31-C34	0.02uF, 3KV	04-5704
	C35-C36	0.0047uF, 3KV	04-5547
	C37	100pF, 3KV	04-5532
	C38	1uF, 35V	04-5656
	C39	68uF, 6.3V	04-5654
	C40	47uF, 10V	04-5666
	C41-C42	0.1uF, 50V	04-5663
TRANSISTORS	Q1	2N7002L	05-5840
	Q2	MJD210RL	05-5843
	Q3	2N7002L	05-5840
	Q4	MJD210RL	05-5843
	Q5	MMBT3904LT1	05-5841
INTEGRATED CIRCUITS	U1	MAX232D	06-6382
	U2	MAX810LEUR	06-6424
	U3	PCF8593TD	06-6403
	U4	AT89C51RC2	06-6893
	U5-U6	24C65ISM	06-6401
	U7	LM285MX-2.5	06-6291
	U8	LTC1257IS8	06-6377
	U9	CD74HC4538M	06-6297
	U10	TLC372ID	06-6290
	U11	CMXT3904TRLF	05-5888
	U12	TLC372ID	06-6290
	U13	CD74HC4538M	06-6297
	U14	TLC27M7ID	06-6292
	U15	CMXT3906TRLF	05-5890
	U16	CMXT3904TRLF	05-5888
DIODES	CR1-CR4	MMBD914LT1	07-6353
	CR5	MMBD7000LT1	07-6355
	CR6	MMBD914LT1	07-6353
	CR7-CR11	GI250-2	07-6266

	<u>Reference</u>	<u>Description</u>	<u>Part Number</u>
POTENTIOMETERS	R9	1 MEG TRIMMER	09-6828
	R11	100K TRIMMER	09-6823
	R12	1 MEG TRIMMER	09-6828
	R18	10K TRIMMER	09-6822
	R25	1 MEG TRIMMER	09-6828
	R32	1 MEG TRIMMER	09-6828
RESISTORS	R1	1K, 1/8W, 1%	12-7832
	R2-R7	22.1K, 1/8W, 1%	12-7843
	R8	2.21K, 1/8W, 1%	12-7835
	R10	100 OHM, 1/8W, 1%	12-7840
	R13	22.1K, 1/8W, 1%	12-7843
	R14	1.5K, 1/8W, 1%	12-7878
	R15	22.1K 1/8W, 1%	12-7843
	R16	10K, 1/8W, 1%	12-7839
	R17	22.1K, 1/8W, 1%	12-7843
	R19-R20	100K, 1/8W, 1%	12-7834
	R21	33.2K, 1/8W, 1%	12-7842
	R22	100 OHM, 1/8W, 1%	12-7840
	R23	33.2K, 1/8W, 1%	12-7842
	R24	392K, 1/8W, 1%	12-7841
	R26	22.1K, 1/8W, 1%	12-7843
	R27-R28	10K, 1/8W, 1%	12-7839
	R29	22.1K, 1/8W, 1%	12-7843
	R30	100K, 1/8W, 1%	12-7834
	R31	1MEG, 1/8W, 1%	12-7844
	R33	10K, 1/8W, 1%	12-7839
	R34	100K, 1/8W, 1%	12-7834
	R35	1.21MEG, 1/8W, 1%	12-7025
	R36	1MEG, 1/8W, 1%	12-7844
	R37	1GIG, FHV-1, 2%	12-7686
	R38	475K, 1/8W, 1%	12-7859
	R39	1MEG, 1/8W, 1%	12-7844
	R40	1MEG, 1/4W, 5%	10-7028
	R41	22.1K, 1/8W, 1%	12-7843
	R42	200 OHM, 1/8W, 1%	12-7846
	R43	4.7 MEG, 1/4W, 5%	12-7030
	R44	1MEG, 1/4W, 5%	10-7028
	R45	1GIG, FHV-1, 2%	12-7686
	R46	2.21K, 1/8W, 1%	12-7835
	R47	1MEG, 1/8W, 1%	12-7844
	R48-R49	22.1K, 1/8W, 1%	12-7843

	<u>Reference</u>	<u>Description</u>	<u>Part Number</u>
TRANSFORMERS	T1	L8050	40-0902
	T2	M177 AUDIO ASSY	4275-083
CONNECTORS	JP1	JUMPER	13-8571
	P1	640456-5 MTA100	13-8057
	P3	747020-2	13-8555
	P4	1-640456-0 MTA100	13-8066
	P5	640456-3 MTA100	13-8081
	P6	640456-6 MTA100	13-8095
MISCELLANEOUS	W1-W10	CLOVERLEAF	18-8771
	SW1	SWITCH DIP-2	08-6712
	B1	LITHIUM BATTERY 3V	22-9786
Display Board, Drawing 337 × 88	BOARD	Completely Assembled Display Board	5337-084
CAPACITORS	C1	47uF, 10V	04-5666
	C2-C5	0.1uF, 50V	04-5663
	C6-C7	27pF, 100V	04-5658
TRANSISTORS	Q1-Q2	2N7002L	05-5840
INTEGRATED CIRCUITS	U1	PCF8574TD	06-6402
	U2 U5	AY0438-I/L	06-6358
RESISTORS	R1-R2	4.75K, 1/8W, 1%	12-7858
	R3-R4	22.1K, 1/8W, 1%	12-7843
	R5	200 OHM, 1/4W, 1%	12-7904
	R6-R11	100 OHM, 1/8W, 1%	12-7966
	R12-R16	10K, 1/8W, 1%	12-7839
	R17	100K, 1/8W, 1%	12-7834
	R19	200 OHM, 1/4W, 1%	12-7904
	R20	100K, 1/8W, 1%	12-7834
	MISCELLANEOUS	DS1-DS4	LED-HLMP2300/2304
DS5-DS6		LED-HLMP2500 GRN	07-6403
DS7-DS8		LED-BACKLITE	07-6451
DSP1-DSP2		LCD-3918-365-920	07-6252
P2		CONN-MTA100 1-640457-0	13-8168
SW1		SWITCH - PUSHBUTTON	08-6716

	<u>Reference</u>	<u>Description</u>	<u>Part Number</u>
Power Supply Board, Drawing 337 × 133	BOARD	Completely Assembled Power Supply Board	5337-133
CAPACITORS	C1	2200uF, 50V	04-5724
	C2-C3	47uF, 10V	04-5666
	C4	22uF, 10V	04-5672
VOLTAGE REGULATOR	VR1	DDPAK5	05-5885
INTEGRATED CIRCUITS	U1	LT1776	06-6512
	U2	LT1304CS8	06-6394
DIODES	CR1	BRIDGE RECT. DF02S	07-6374
	CR2-CR4	RECTIFIER CMSH1-40M	07-6411
	CR7-CR11	GI250-2	07-6266
RESISTORS	R1-R2	100K 1/8W, 1%	12-7834
	R3	33.2K, 1/8W, 1%	12-7842
	R4	10K, 1/8W, 1%	12-7839
	R5-R6	22.1K, 1/8W, 1%	12-7843
	R7	37.4K, 1/8W, 1%	12-7035
	R8	12.1K, 1/8W, 1%	12-7879
	R9	1.5K, 1/8W, 1%	12-7878
	R10	37.4K, 1/8W, 1%	12-7035
	R11	5 OHM, 3W, 5%	12-7718
	R12	4.75K, 1/8W, 1%	12-7858
	R13	100K, 1/8W, 1%	12-7834
	R14	37.4K, 1/8W, 1%	12-7035
CONNECTORS	P7	MTA100 640456-3	13-8081
	P8	MTA156 640445-3	13-8125
	P9	MTA100 640456-2	13-8073
INDUCTORS	L1	100uH DT3316	21-9875
	L2	22uH CD43	21-9808
Wiring Diagram, Drawing 337 × 182			
SWITCHES	S1	ON/OFF DM62J12S205PQ	08-6715
	S2	MICRO FOR TRAY BZ-2RD-A2 (M3030 only)	08-6538
	S111	513384	08-6656

	<u>Reference</u>	<u>Description</u>	<u>Part Number</u>
POTENTIOMETER	R1	10K NON-LOCKING POT	09-6753
CONNECTORS	J1	640442-5 MTA100	13-8140
	J2	1-640442-0 MTA100	13-8136
	J4	1-640442-0 MTA100	13-8136
	J5	640440-3 MTA100	13-8080
	J6	640442-6 MTA100	13-8171
	J7	640440-3 MTA100	13-8080
	J8	640428-3 MTA156	13-8124
	J9	640440-2 MTA100	13-8202
	J10	AC RECEPTACLE W/FILTER	21-9830
MISCELLANEOUS	F1	1A FUSES	21-9704
	B1	BATTERY 12V	21-9898
	DS1	UNIMORPH	21-9251
	*	BCD BOARD	5261-154
	2EA	KNOB	08-6601
	1EA	10K POT –VOLUME	09-6753
	*	HANDLE – BLACK VINYL	21-9346
	*	CALIBRATION COVER	9337-115
Model 3030 ONLY	*	DETECTOR ASSEMBLY	4337-100
	C111	0.01uF, 2KV	04-5525
	J11	UG706/U	
		Screw-in “C” Connector	13-7751
	R001-R004	4.75 MEG, 1/8 W, 1 %	12-7995
	R011-R013	4.75 MEG, 1/8 W, 1 %	12-7995
	R101-R104	4.75 MEG, 1/8 W, 1 %	12-7995
	R111	10 MEG, 1/8 W, 1 %	12-7996
	V001	2” PMT	01-5649
	*	VOLTAGE DIVIDER BOARD	5002-571
	*	WINDOW W/MYLAR	4337-124
	*	SAMPLE DRAWER	7337-098
	1EA	SAMPLE DRAWER SCREW	7337-114
	*	TRAY LOCK	7337-129
	1EA	KNOB-POINTER	08-6608

A dark gray square graphic with the word "Section" in white at the top and the number "11" in large white font below it.

Drawings and Diagrams

Amplifier/Processor Board, Drawing 337 x 365

Amplifier/Processor Board, Component Outline, Drawing 337 × 366 (2 sheets)

Display Board, Drawing 337 × 88 (4 Sheets)

Display Board, Component Outline, Drawing 337 × 89

Power Supply Board, Drawing 337 × 133

Power Supply Board, Component Outline, Drawing 337 × 134A

Wiring Diagram, Drawing 337 × 182

1

2

3

4

5

A

A

B

B

C

C

D

D

E

E

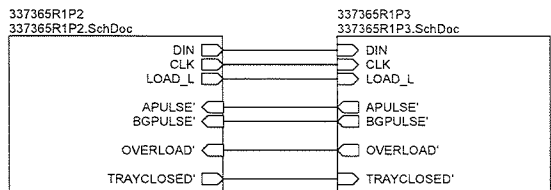

		MEASUREMENTS, INC.		PO Box 810 501 Oak Street Sweetwater, Texas 79556 U.S.A. 1-800-622-0828	
Drawn: PAB	7/13/2017	Title: Amp/Processor Board			
Design: RSS	7/13/2017	Model: 3030			
		Board#: 5337-365			
Approve:	Sheet: 1 of 3	Series	Sheet		
Print Date: 7/13/2017 4:12:49 PM	Rev: 1			337	365
<small>W:\Projects\MIM\337365R1P3\337366R1P3.SchDoc</small>					

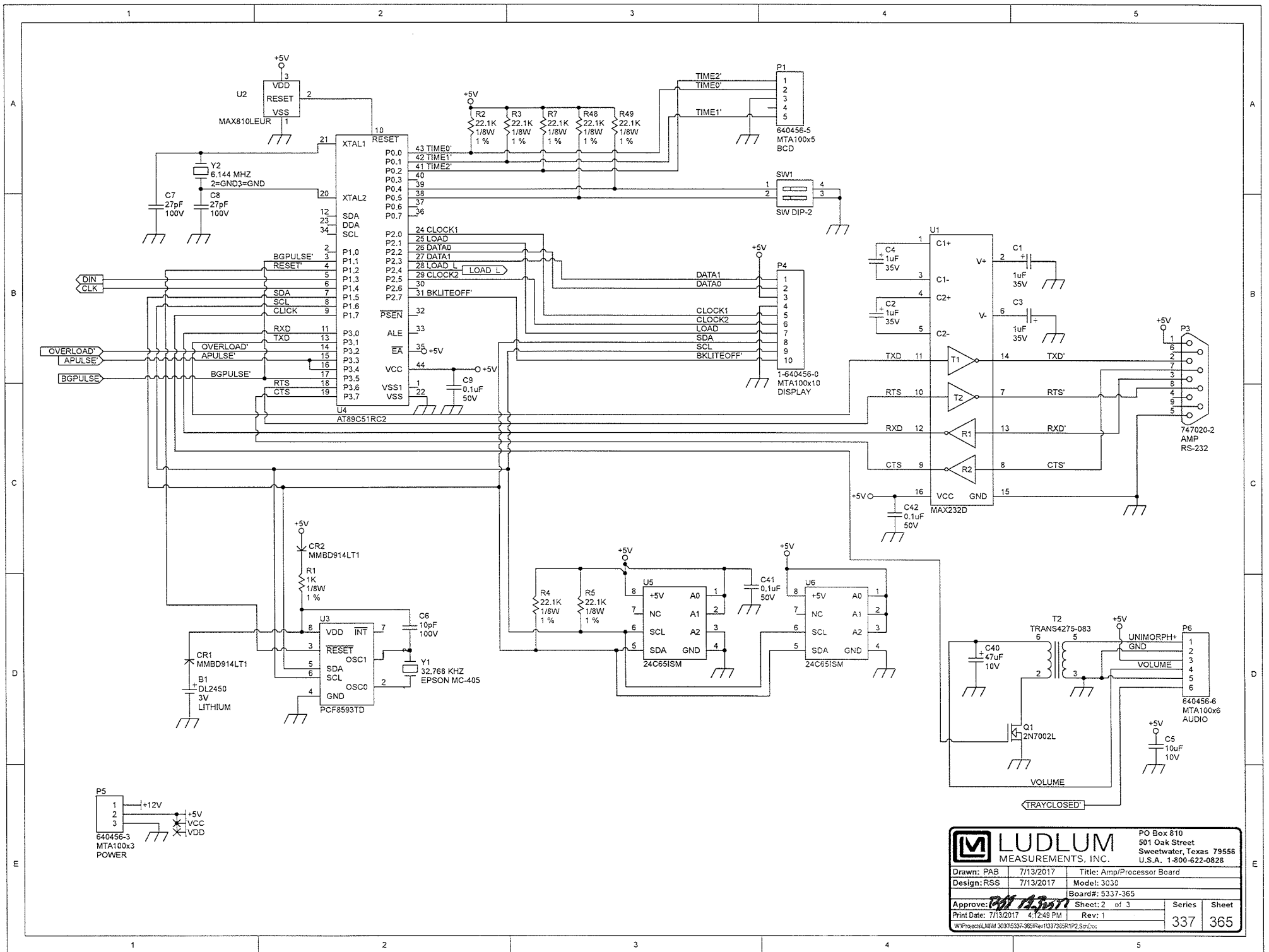

		PO Box 810 501 Oak Street Sweetwater, Texas 79556 U.S.A. 1-800-622-0828	
		Drawn: PAB Design: RSS	Title: Amp/Processor Board Model: 3030
Approve: <i>[Signature]</i> Print Date: 7/13/2017 4:12:48 PM	Rev: 1	Series: 337	Sheet: 365

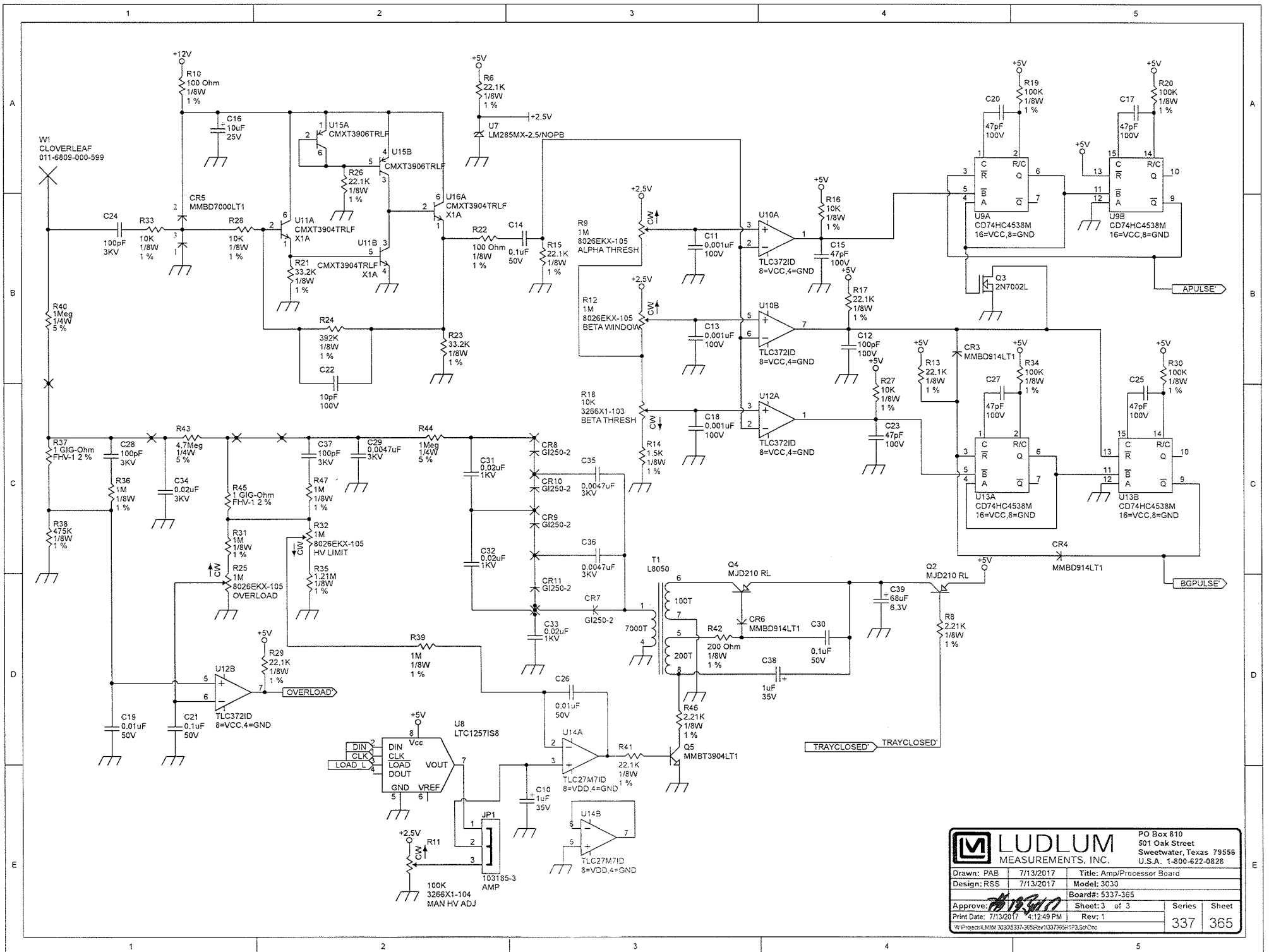

		PO Box 810 501 Oak Street Sweetwater, Texas 79556 U.S.A. 1-800-622-0828	
		Drawn: PAB Design: RSS	Title: Amp/Processor Board Model: 3030
Approve: <i>[Signature]</i> Print Date: 7/13/2017 4:12:49 PM	Rev: 1	Series:	Sheet:
WWW.LUDLUM.COM 3030/5337-365/Rev1/337365R1/PS_Sp2.Doc		337	365

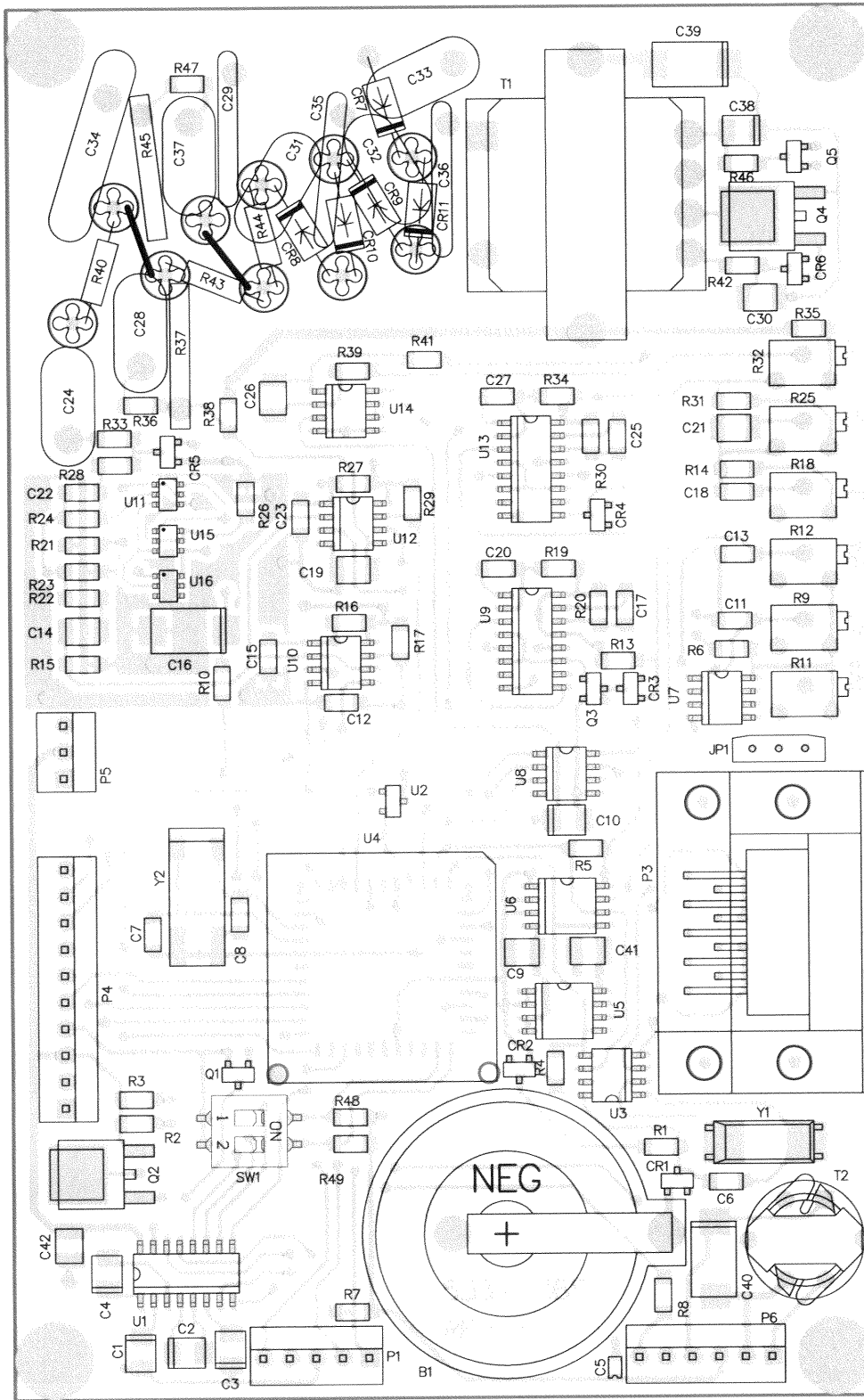

LUDLUM MEASUREMENTS, INC. PO Box 810
501 Oak Street
Sweetwater, TX 79556
U.S.A. 1-800-622-0828

Title: Amp/Processor Board			
Drawn: PAB	7/13/2017	Model: 3030	
Design: RSS	7/13/2017	Board#: 5337-365	
Approve: <i>[Signature]</i>	<i>[Signature]</i>	Rev: 1	
PCBA Drawing		SCALE: 0.95	Series Sheet
Print Date: 7/13/2017	4:56:43 PM	Top Overlay	337 366

W:\Projects\MM 3030\5337-365\Rev1\337365R1_Assy.PcbDoc

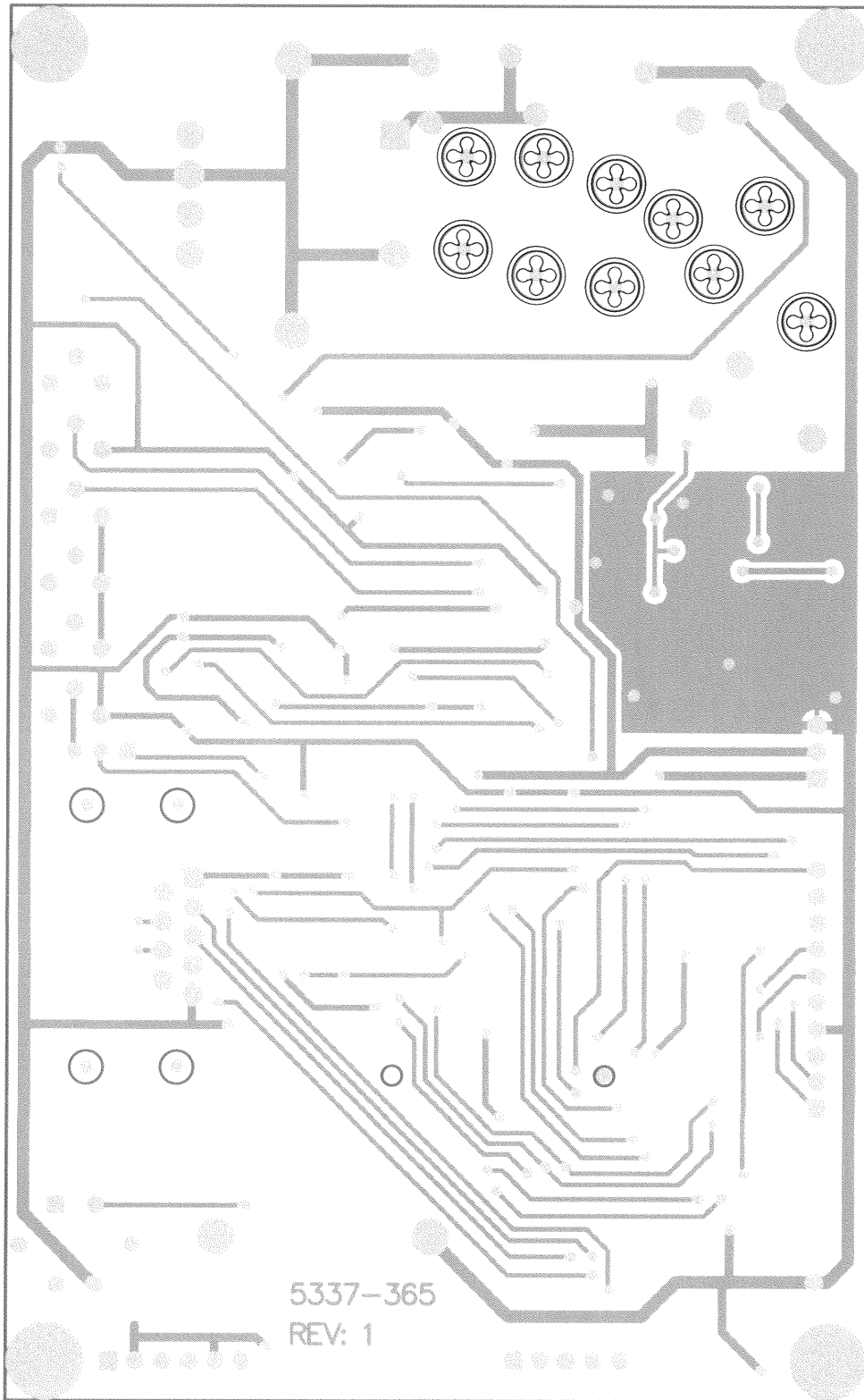

5337-365
REV: 1

2

		PO Box 810 501 Oak Street Sweetwater, TX 79556 U.S.A. 1-800-622-0828		
Title: Amp/Processor Board				
Drawn: PAB	7/13/2017	Model: 3030		
Design: RSS	7/13/2017	Board#: 5337-365		
Approve: <i>RSS</i>	<i>7/13/2017</i>	Rev: 1		
PCBA Drawing		SCALE: 0.95	Series	Sheet
Print Date: 7/13/2017	4:56:46 PM	Bottom Overlay	337	366
W:\Projects\LLMM 3030\5337-365\Rev1\337365R1_Assy.PcbDoc				

1 2 3 4 5 6 7

G
F
E
D
C
B
A

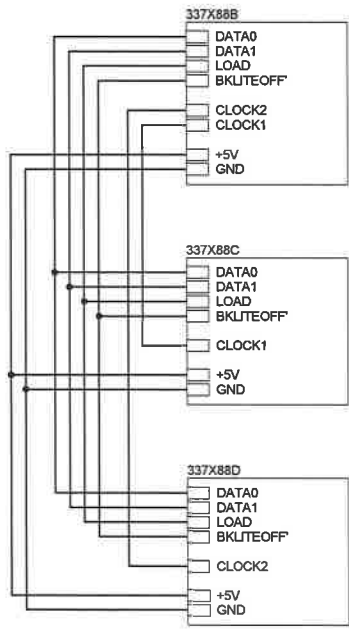

		PO Box 810 501 Oak Street Sweetwater, Texas 79556 U.S.A. 1-800-622-0828	
Drawn: JK	28-FEB-01	Title: DISPLAY BOARD	
Design: RSS	28-FEB-01	Model: M3030	
Check:		Board#: 5337-084	
Approve: <i>[Signature]</i>		Sheet: 1 of 4	Series Sheet
11:18:46	19-Jun-2009	Rev: 1.0	337 88
X:\Projects\MIM3030\M3030 Dwg - Documents\5337-084\Rev1.0\337X88A			

1 2 3 4 5 6 7

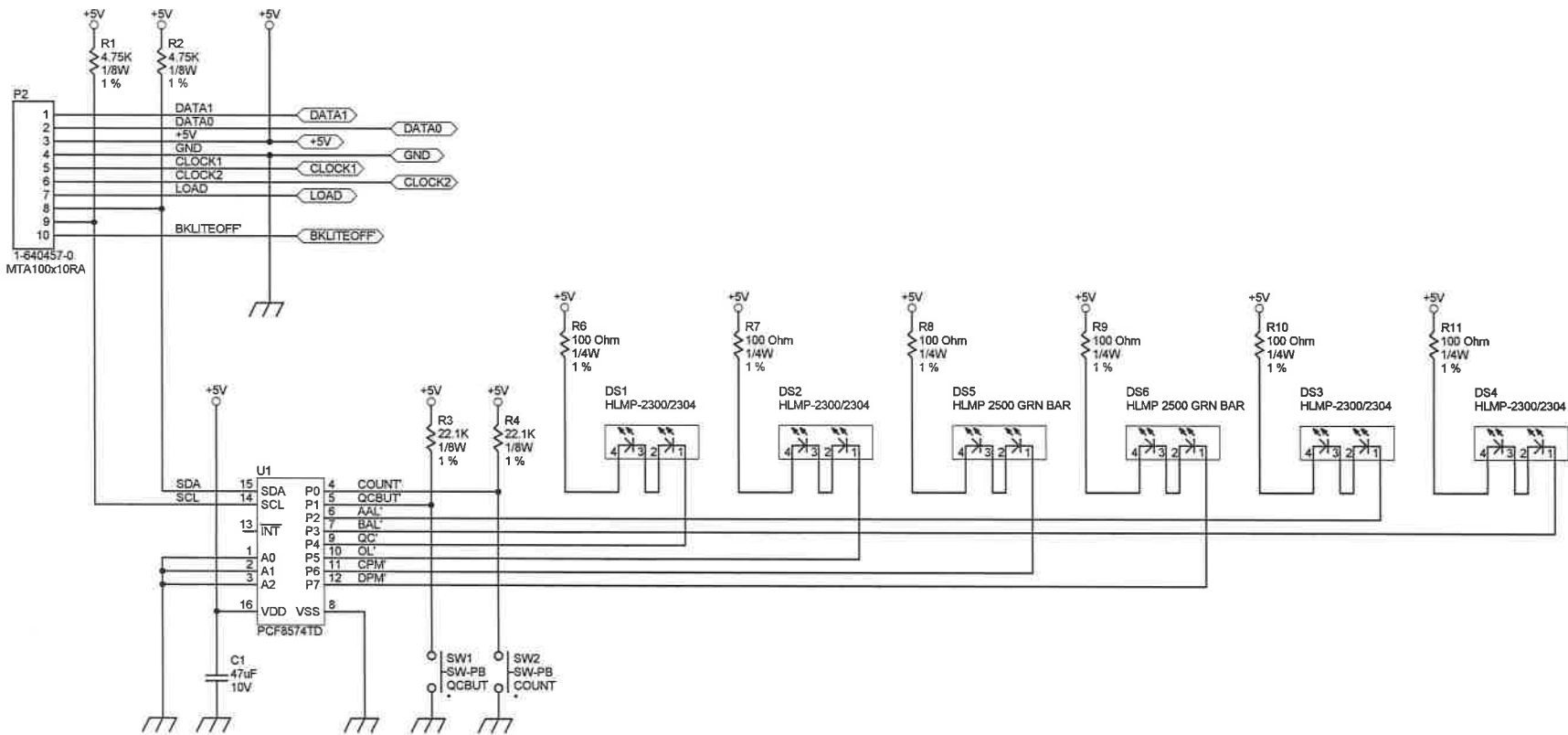

		PO Box 810 501 Oak Street Sweetwater, Texas 79556 U.S.A. 1-800-622-0828		
		Title: DISPLAY BOARD		
Drawn: JK	28-FEB-01	Design: RSS	28-FEB-01	Model: M3030
Check:	Board#: 5337-064	Approve: <i>R.A. Blunt</i>	Sheet: 2 of 4	Series
11-18-43	19-Jun-2009	Rev: 1.0	337	88

X:\Projects\LM3030\M3030 Dwg - Documents\5337-06 Rev1 0307388

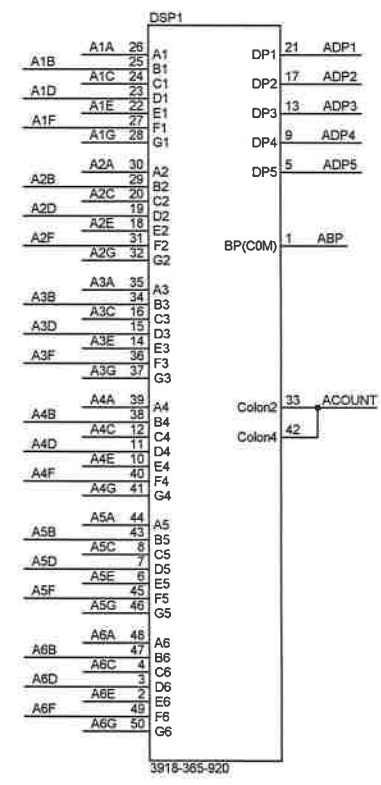
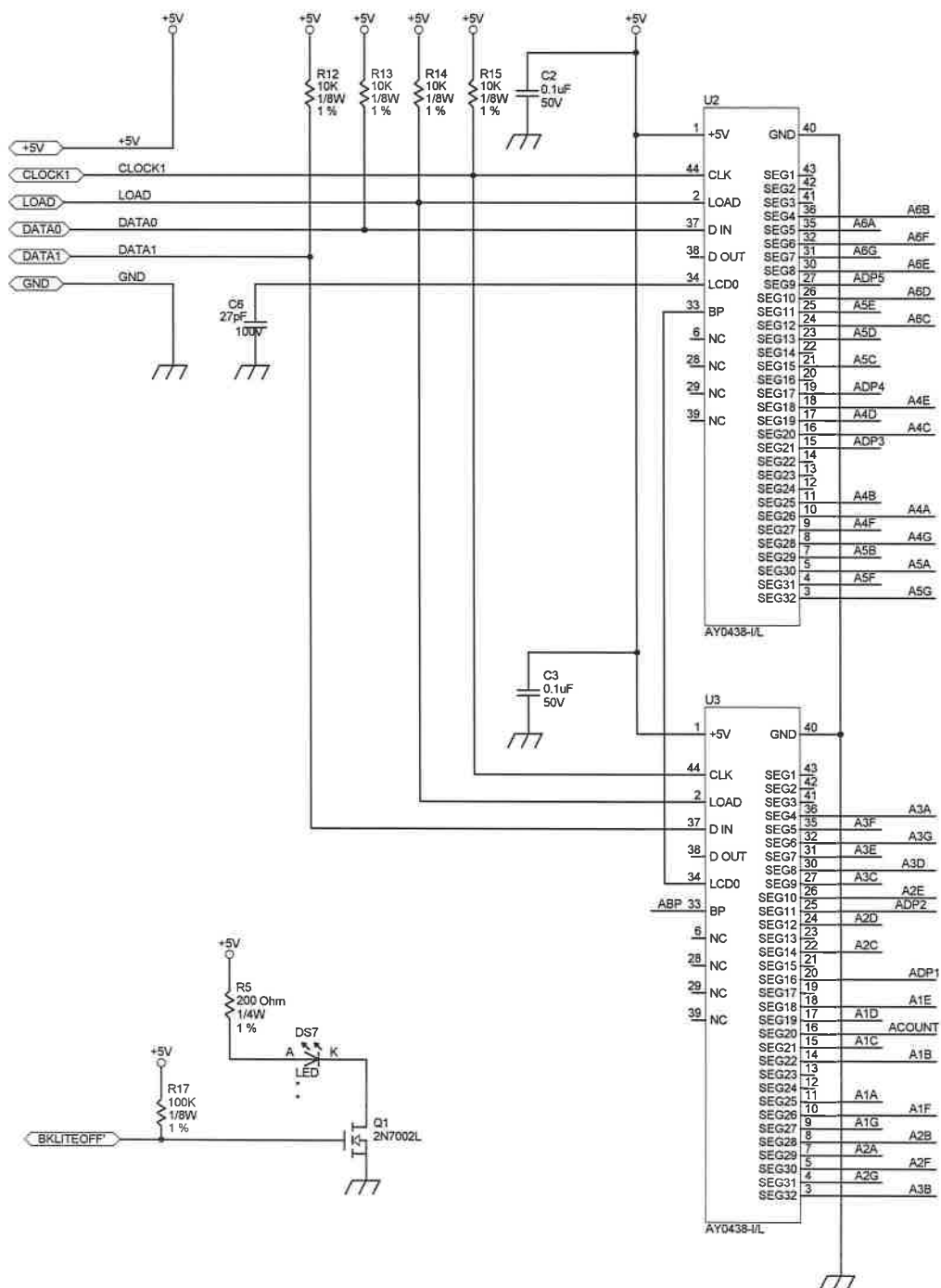

LUDLUM MEASUREMENTS, INC.
 PO Box 810
 501 Oak Street
 Sweetwater, Texas 79556
 U.S.A. 1-800-622-0828

Drawn: JK	28-FEB-01	Title: DISPLAY BOARD		
Design: RGS	28-FEB-01	Model: M3030		
Check:		Board#: 5337-084		
Approve: <i>[Signature]</i>	11-18-39	Sheet: 3 of 4	Series	Sheet
		Rev: 1.0	337	88

\\ProjectL\MM3\3030\3030.Dwg - Documents\0337-084\rev1_0307180C

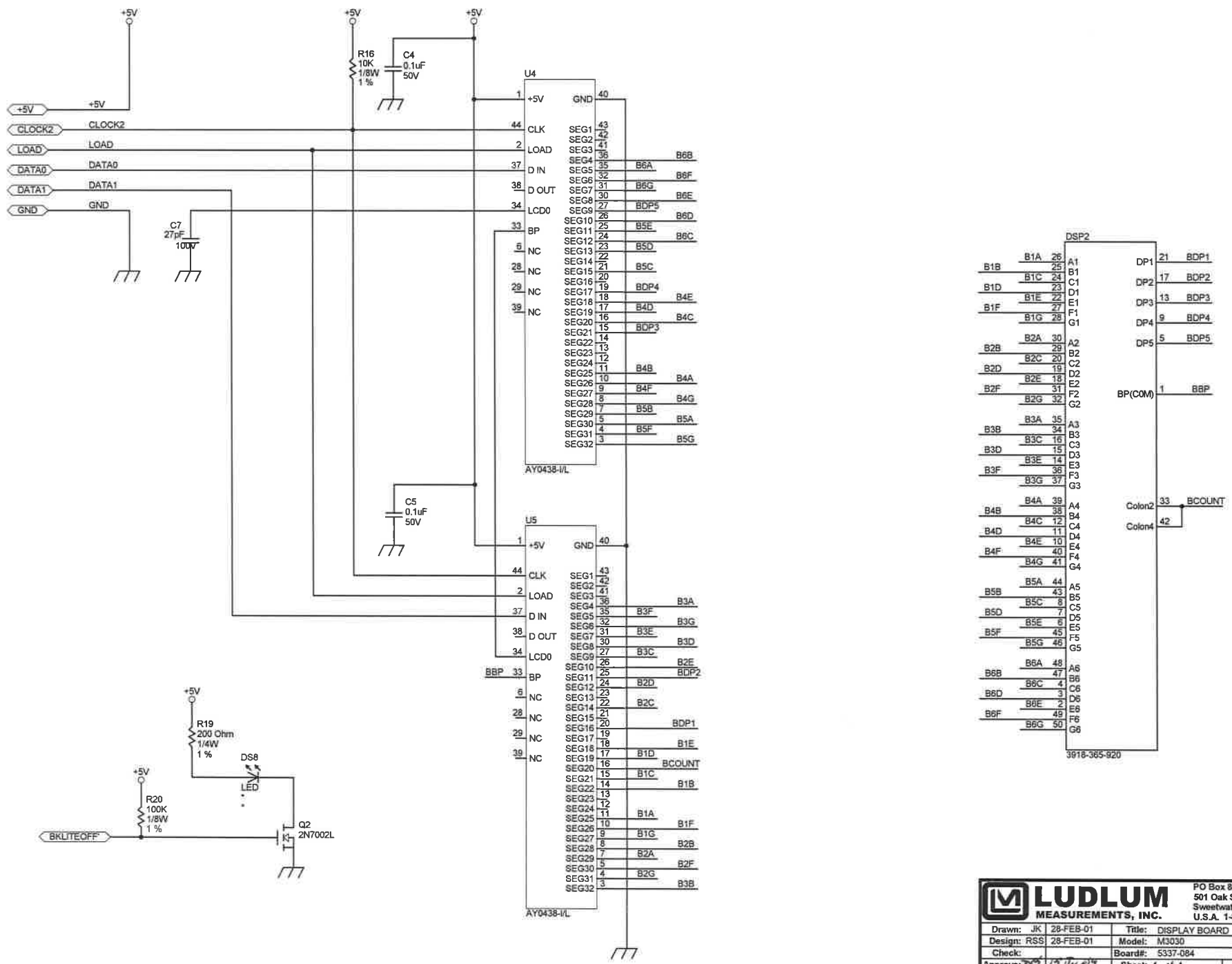

LUDLUM MEASUREMENTS, INC.
 PO Box 810
 501 Oak Street
 Sweetwater, Texas 79556
 U.S.A. 1-800-622-0828

Drawn: JK	28-FEB-01	Title: DISPLAY BOARD
Design: RSS	28-FEB-01	Model: M3030
Check:		Board#: 5337-084
Approved: <i>[Signature]</i>	19-Jun-2009	Rev: 1.0
11:18:38		Sheet: 4 of 4
		Series: 337
		Sheet: 88

X:\P\resist\M3030\M3030.Dwg - Document#5337-084ver1.0337r88D

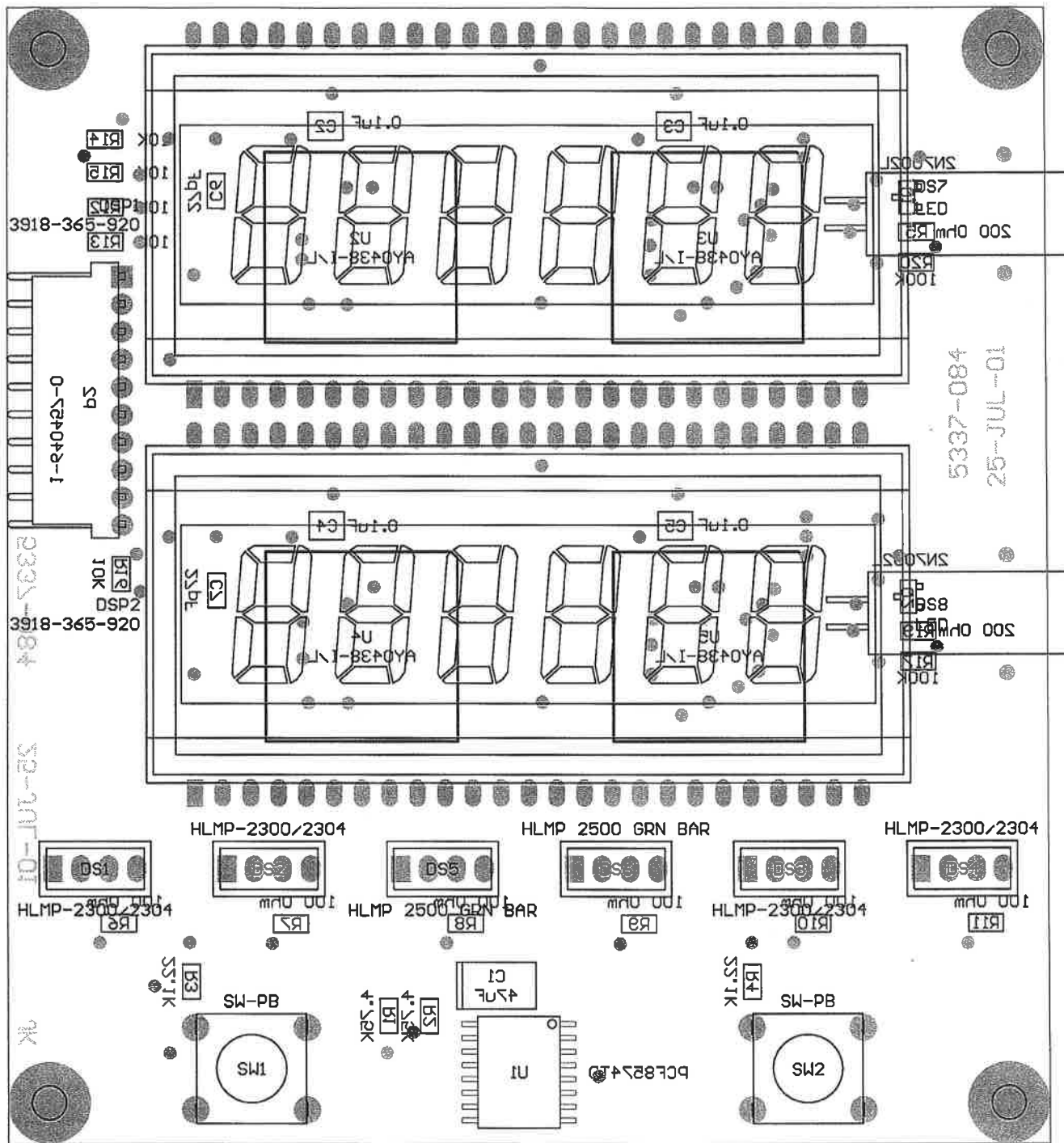

Drawn:	JK	25-JUL-01	Title:		
Design:	RSS	25-JUL-01	M3030 DISPLAY BOARD		
Check:			Model: M3030		
Approve:	<i>RSS</i>	<i>6 Feb 09</i>	Board#: 5337-084		
Layer:			Rev: 1.0	Series	Sheet
Mech.1					
Mech.2	MID:				
Mech.3	15:31:20	6-Feb-2009	SCALE: 1.27	337	89
Mech.4					

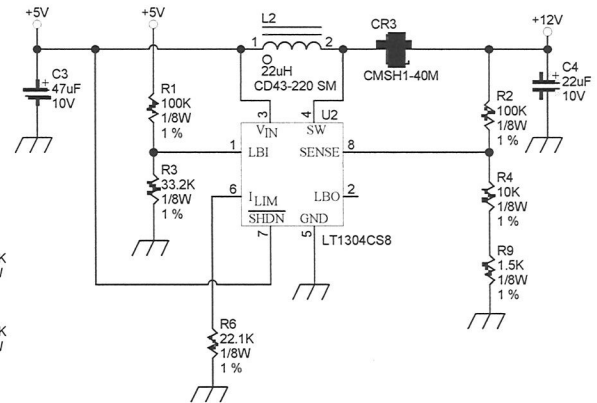
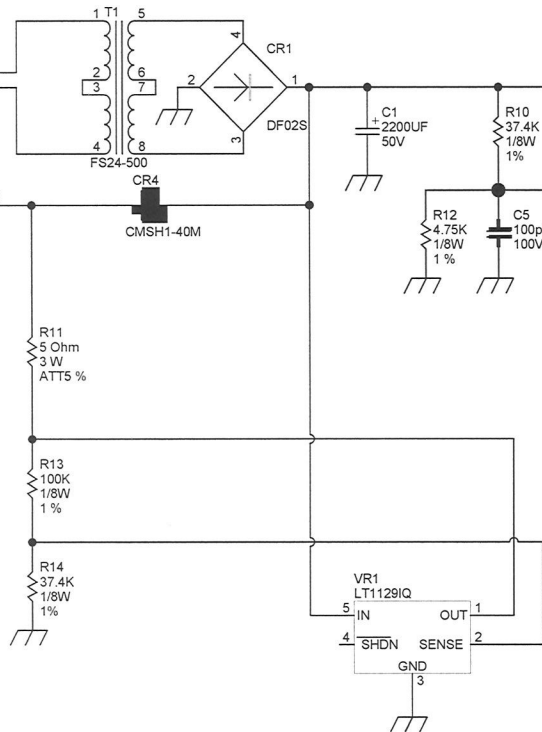
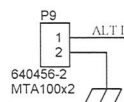
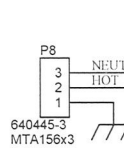
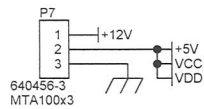

		PO Box 810 501 Oak Street Sweetwater, Texas 79556 U.S.A. 1-800-622-0828	
Drawn: JK	08/06/2001	Title: POWER SUPPLY BOARD	
Design: RSS	08/06/2001	Model: 3030	
		Board#: 5337-133	
Approve: <i>[Signature]</i>		Sheet: 1 of 1	Series
Print Date: 7/10/2014 4:37:42 PM		Rev: 2	Sheet
W:\Projects\LMM\3030\5337-133\Rev2\337133R2P1.SchDoc		337	133

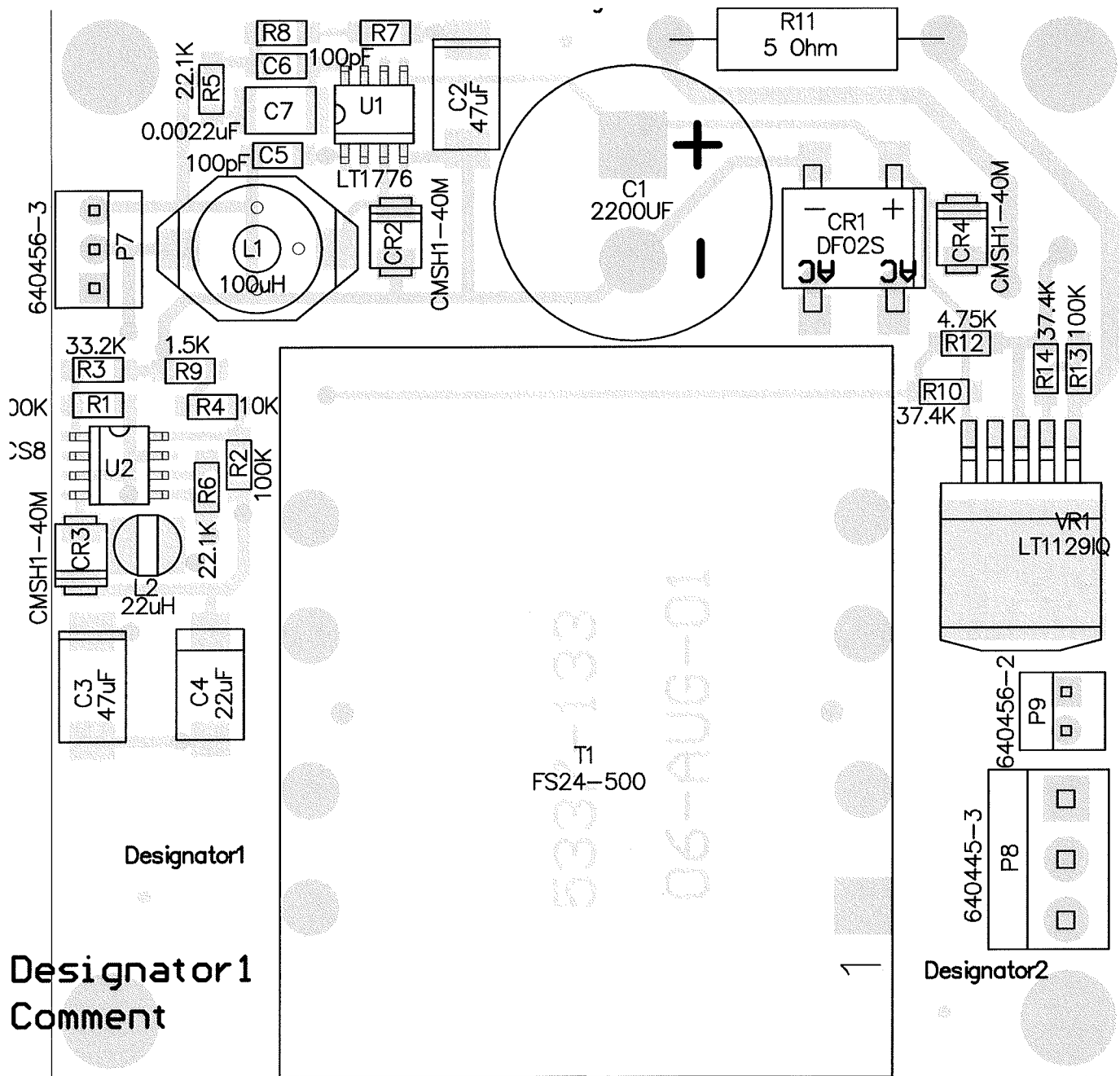



LUDLUM

MEASUREMENTS, INC.

PO Box 810
501 Oak Street
Sweetwater, TX 79556
U.S.A. 1-800-622-0828

Title: POWER SUPPLY BOARD			
Drawn: JK	08/06/2001	Model: 3030	
Design: RSS	08/06/2001	Board#: 5337-133	
Approve: <i>RDS</i>	<i>11 Jul 14</i>	Rev: 2	
Print Date:		SCALE: 1.00	Series
7/10/2014	4:37:50 PM		
		Top Overlay	Sheet 134 A
W:\Projects\LMIM 3030\5337-133\Rev2\337133R2_Assy.PcbDoc			

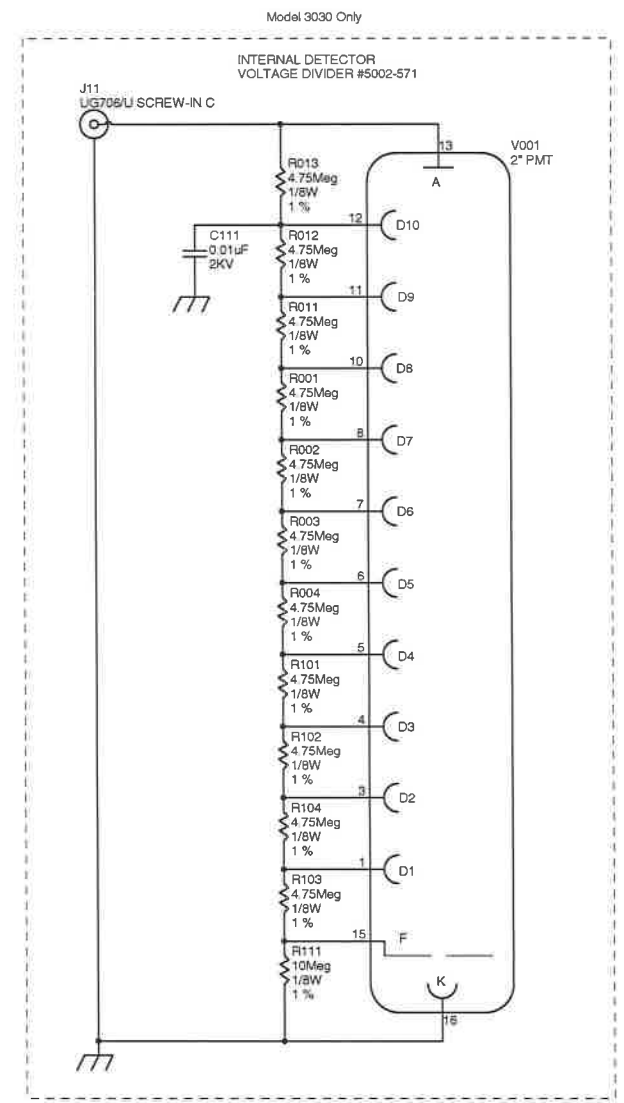
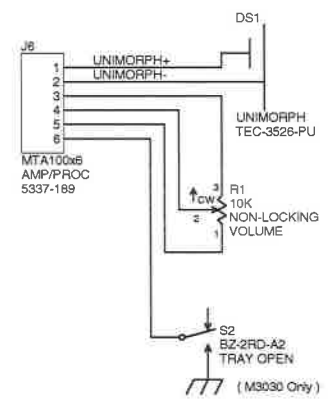
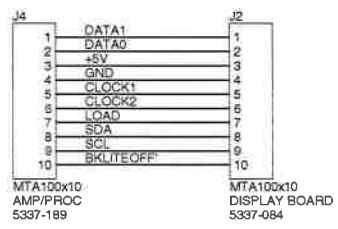
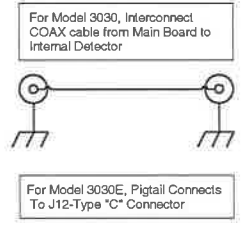
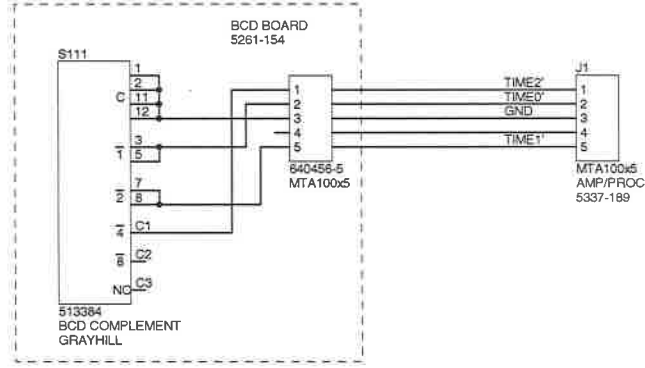
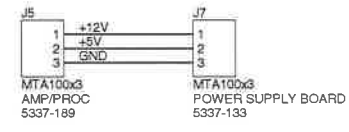
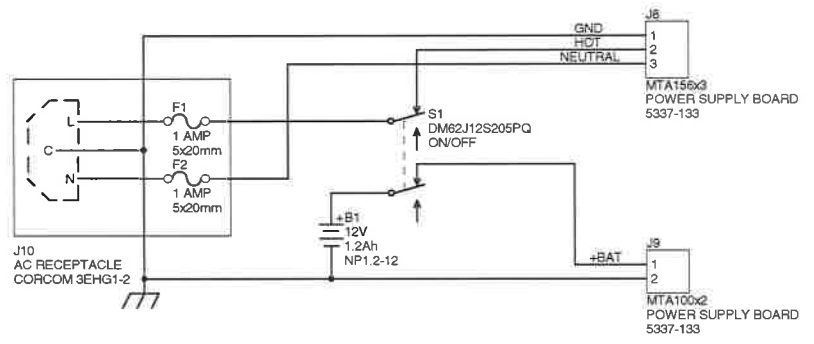

LUDLUM MEASUREMENTS, INC.		PO Box 819 501 Oak Street Sweetwater, Texas 79556 U.S.A. 1-800-622-0828	
Drawn: SA	9/07/04	Title: Wiring Diagram	
Design: RSS	13-SEP-00	Model: 3030 & 3030E	
Check:		Board#: 337-182	
Approve: <i>RSS</i>	13.12.13	Sheet: 1 of 1	Series
	1-Apr-2005	Rev: 1.0	Sheet
337x182		337	182



Model 3030-2 and 3030E-2

The Ludlum Model 3030-2 (LMI Part # 48-3992) and Model 3030E-2 (LMI Part # 48-3448-2) are dual-channel counters designed for simultaneous alpha and beta sample measurement. Below are the differences between the Model 3030/3030E and the 3030-2/3030E-2.

Counting Mode

The counts per minute (CPM), Becquerel (BQ), or counts per second (CPS) modes may be enabled to allow the count to be converted (automatically, in real time) to CPM, Becquerel, or CPS. The Becquerel and CPS display modes will show the count with two decimal places.

Overload

The LCD display will toggle between the current reading and OL on both the alpha and beta displays.

Sample Logging

The code for the logged sample changes to the following:

- S - Scaler
- C - Counts per minute
- B - Becquerel
- P - Counts per second

RS-232 Command Differences

The "D" command to set/read the counting mode changes to the following:

- D0 - Set count mode to scaler
- D1 - Set count mode to counts per minute
- D2 - Set count mode to Becquerel
- D3 - Set count mode to counts per second
- D4 - Read current count mode

The D4 command will return the following string:

- "SCA" - Scaler
- "CPM" - Counts per minute
- "BQ " - Becquerel
- "CPS" - Counts per second

PC Interface software (LMI Part# 1370-043)

Version 1.4.9 or higher is required and may be downloaded from the LMI website <http://www.ludlums.com>.

Appendix

B

Model 3030 DC Modification

A DC modification is available to replace the 120 Vac power input with a 12 Vdc input. The advantages of this modification is that it minimizes the available voltage and currents within the enclosure and brings the power converter outside the instrument (wall wart) for convenient replacement in the event of failure.

The modification can be made at the time of order (via part # 4337-213) or ordered as a conversion kit (part # 4337-212) for customer installation. The modification requires:

1. Removal of AC receptacle from back of Model 3030.
2. Attaching jack 7121A (21-9647) to DC plate (9337-215) on the back panel of the Model 3030 and attaching to the Model 3030's back panel.
3. Removal of T1 and CR1 on power supply board (5337-133).
4. Addition of diode 1N5819 (07-6306) cathode side to pin 5 of U1 and anode side to pin 3 of P8 (see picture below for proper diode location).
5. Jumpering black (hot) wire to positive lead of jack 712A and 4.5 inch green #22 gauge wire from ground lead of jack to chassis ground.
6. Shrink wrapping ends of neutral and ground wires.

