

**LUDLUM MODEL 15  
NEUTRON COUNTER WITH  
DETECTOR MODELS 44-7 & 42-14H**

**June 2020**

**Serial Number 336330 and Succeeding  
Serial Numbers**

# LUDLUM MODEL 15 NEUTRON COUNTER WITH DETECTOR MODELS 44-7 & 42-14H

**June 2020**

**Serial Number 336330 and Succeeding  
Serial Numbers**

This Manual also applies to Serial Numbers of Model 15 Instruments where the accompanying BF-3 detector has been replaced by He-3.  
He-3 detectors are labeled with an "H"



**LUDLUM MEASUREMENTS, INC**  
501 OAK STREET, P.O. BOX 810  
SWEETWATER, TEXAS 79556  
325-235-5494, FAX: 325-235-4672

## **STATEMENT OF WARRANTY**

Ludlum Measurements, Inc. warrants the products covered in this manual to be free of defects due to workmanship, material, and design for a period of twelve months from the date of delivery. The calibration of a product is warranted to be within its specified accuracy limits at the time of shipment. In the event of instrument failure, notify Ludlum Measurements to determine if repair, recalibration, or replacement is required.

This warranty excludes the replacement of photomultiplier tubes, G-M and proportional tubes, and scintillation crystals which are broken due to excessive physical abuse or used for purposes other than intended.

There are no warranties, express or implied, including without limitation any implied warranty of merchantability or fitness, which extend beyond the description of the face there of. If the product does not perform as warranted herein, purchaser's sole remedy shall be repair or replacement, at the option of Ludlum Measurements. In no event will Ludlum Measurements be liable for damages, lost revenue, lost wages, or any other incidental or consequential damages, arising from the purchase, use, or inability to use product.

## **RETURN OF GOODS TO MANUFACTURER**

If equipment needs to be returned to Ludlum Measurements, Inc. for repair or calibration, please send to the address below. All shipments should include documentation containing return shipping address, customer name, telephone number, description of service requested, and all other necessary information. Your cooperation will expedite the return of your equipment.

**LUDLUM MEASUREMENTS, INC.  
ATTN: REPAIR DEPARTMENT  
501 OAK STREET  
SWEETWATER, TX 79556**

**800-622-0828 325-235-5494  
FAX 325-235-4672**

REV #	ALTERATIONS	DATE	BY
1	VALID	12-6-89	BK
2	CHANGED ARTWORK	4-28-05	CMC
3	ADDED DO NOT DISCARD SYMBOL	11-21-06	CMC

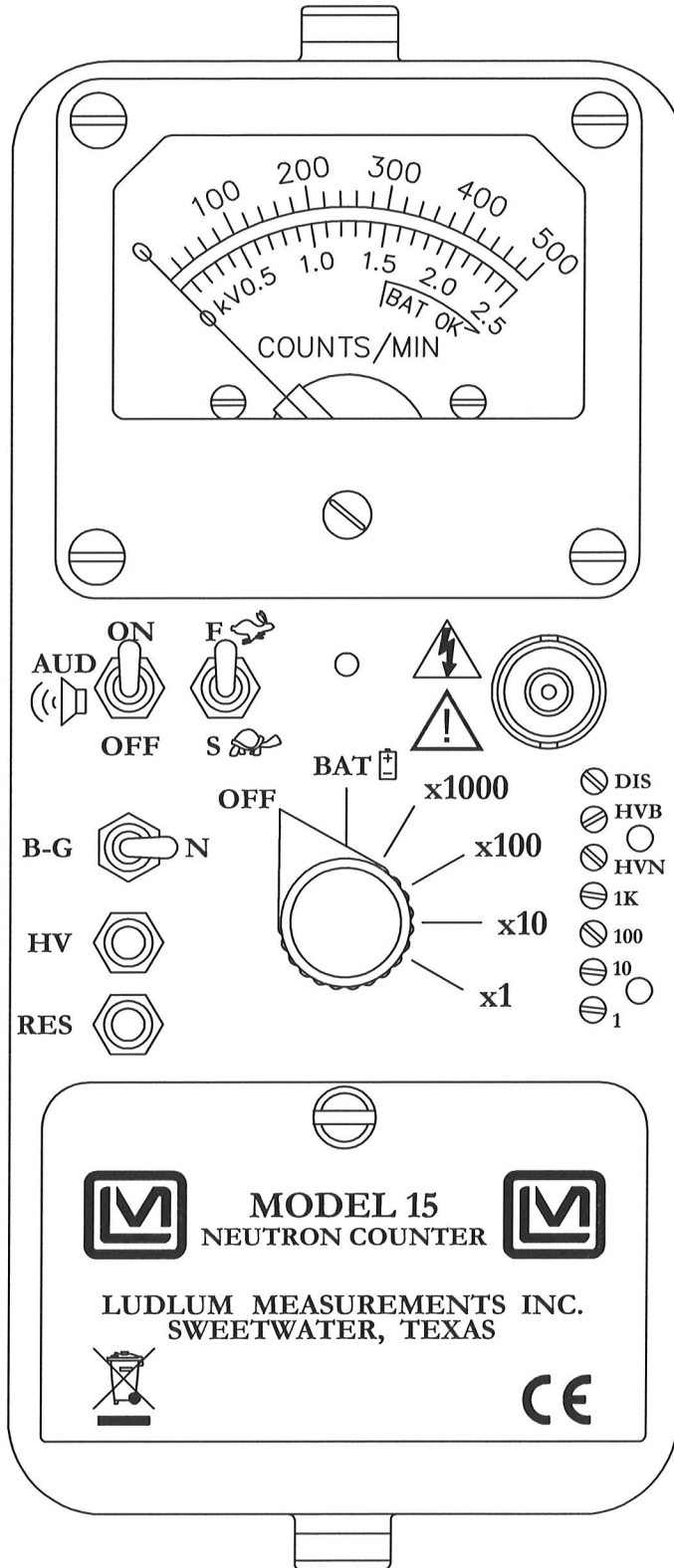

DWN	DATE	CHK	DATE	APP	DATE
CMC	11-21-06			Now	11-21-06
PART NUM: 4363-334				SCALE: FULL <input checked="" type="checkbox"/> OTHER	
TITLE M 15 NEUTRON COUNTER					
LUDLUM MEASUREMENTS, INC. 501 DMK STREET SWEETWATER, TEXAS 79556		SERIES	SHEET		
		363	255		

# Table of Contents

---

<b><i>Introduction</i></b>	<b><i>1</i></b>
<b><i>Getting Started</i></b>	<b><i>2</i></b>
Unpacking and Repacking	2-1
Battery Installation	2-2
Connecting a Detector to the Instrument	2-2
Battery Test	2-2
Instrument Test	2-3
Operational Check	2-4
<b><i>Specifications</i></b>	<b><i>3</i></b>
Model 42-14H Neutron Detector	3-2
Model 44-7 Alpha-Beta-Gamma Detector	3-2
<b><i>Identification of Controls and Functions</i></b>	<b><i>4</i></b>
<b><i>Safety Considerations</i></b>	<b><i>5</i></b>
Environmental Conditions for Normal Use	5-1
Warning Markings and Symbols	5-1
Cleaning and Maintenance Precautions	5-2
<b><i>Calibration and Maintenance</i></b>	<b><i>6</i></b>
Calibration	6-1
Calibration of Discriminator	6-1
Calibration of Ratemeter	6-1
Calibration of High Voltage Readout	6-2
Calibration of High Voltage	6-2
Calibration of High Voltage for Neutrons	6-2
Efficiency Calibration	6-3
Maintenance	6-3
Recalibration	6-3
Batteries	6-4
<b><i>Troubleshooting</i></b>	<b><i>7</i></b>

<b>Troubleshooting the Electronics</b>	<b>7-1</b>
<b><i>Technical Theory of Operation</i></b>	<b><i>8</i></b>
<b>Input</b>	<b>8-1</b>
<b>Amplifier</b>	<b>8-1</b>
<b>Discriminator</b>	<b>8-1</b>
<b>Audio</b>	<b>8-1</b>
<b>Digital Analog Converter</b>	<b>8-2</b>
<b>Scale Ranging</b>	<b>8-2</b>
<b>Meter Drive</b>	<b>8-2</b>
<b>Meter Compensation</b>	<b>8-2</b>
<b>Fast / Slow Time Constant</b>	<b>8-2</b>
<b>Low Voltage Supply</b>	<b>8-3</b>
<b>Low Voltage Reference</b>	<b>8-3</b>
<b>High Voltage Supply</b>	<b>8-3</b>
<b><i>Recycling</i></b>	<b><i>9</i></b>
<b><i>Parts List</i></b>	<b><i>10</i></b>
<b>Model 15 Neutron Counter with Detectors</b>	<b>10-1</b>
<b>Main Board, Drawing 464 x 655</b>	<b>10-1</b>
<b>Calibration Board, Drawing 363 x 585</b>	<b>10-3</b>
<b>Wiring Diagram, Drawing 363 x 587</b>	<b>10-4</b>
<b><i>Drawings and Diagrams</i></b>	<b><i>11</i></b>

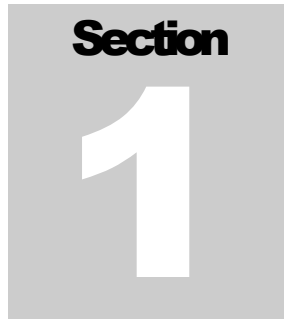
A gray square graphic containing the word "Section" in a bold, black, sans-serif font at the top, and a large, white, bold number "1" centered below it.

## Introduction

---

The Model 15 is a Neutron Counter coupled to a Model 42-14H Neutron Detector and moderator, as well as a Model 44-7 GM Detector. This combination provides the required electronic circuitry and detectors for measuring and monitoring alpha, beta, and gamma radiation, in addition to fast and slow neutrons (removable moderator for thermal neutrons).

The instrument provides four linear ranges used in combination with a CPM (counts per minute) meter dial. The instrument features a regulated high-voltage power supply, unimorph speaker with audio ON-OFF capability, fast-slow meter response, meter reset button, and a six-position switch for selecting battery check or range multiples of  $\times 1$ ,  $\times 10$ ,  $\times 100$ , and  $\times 1000$ . Each range multiplier has its own calibration potentiometer.

Other controls include: two-position toggle switch for selection of alpha-beta-gamma (B-G) or neutron detection (N), high-voltage check (HV) and meter reset (RES) buttons, and front-panel calibration controls for independent high voltage and discrimination adjustments.

The unit body and meter housing are made of cast aluminum and the can is 0.23 cm (0.090 in.) thick aluminum. The unit is powered by two "D" cell batteries for operation from  $-20$  to  $50$  °C ( $-4$  to  $122$  °F). For instrument operation below  $0$  °C ( $32$  °F), either very fresh alkaline or rechargeable NiCd batteries should be used.

**Section****2**

## Getting Started

---

### Unpacking and Repacking

Remove the calibration certificate and place it in a secure location. Remove the instrument and accessories (batteries, cable, detectors, etc.) and ensure that all of the items listed on the packing list are in the carton. Check individual item serial numbers and ensure calibration certificates match. The Model 15 serial number is located on the front panel below the battery compartment. Most Ludlum Measurements detectors have a label on the base or body of the detector for model and serial number identification.

**Important!**

If multiple shipments are received, ensure that the detectors and instruments are not interchanged. Each instrument is calibrated to specific detectors, and therefore not interchangeable.

To return an instrument for repair or calibration, provide sufficient packing material to prevent damage during shipment.

Every returned instrument must be accompanied by an **Instrument Return Form**, which can be downloaded from the Ludlum website at [www.ludlums.com](http://www.ludlums.com). Find the form by clicking the “Support” tab and selecting “Repair and Calibration” from the drop-down menu. Then choose the appropriate Repair and Calibration division where you will find a link to the form.

**Model 44-7**

When shipping a Model 44-7 by air, it is necessary to ship the tube in a sealed container to avoid sudden atmospheric changes, which could rupture the tube.



## Battery Installation

Ensure the Model 15 range selector switch is in the OFF position. Open the battery lid by pushing down and turning the quarter-turn thumbscrew counterclockwise a quarter of a turn. Install two "D" size batteries in the compartment.

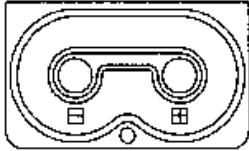

Note the (+) and (-) marks inside the battery door. Match the battery polarity to these marks. Close the battery box lid, then push down and turn the quarter-turn thumb screw clockwise a quarter of a turn.

### Note:

The center post of a flashlight battery is positive. The batteries are placed in the battery compartment in opposite directions.

## Connecting a Detector to the Instrument

### Caution!

The detector operating voltage (HV) is supplied to the detector via the detector input connector. A mild electric shock may occur if you make contact with the center pin of the input connector. Switch the Model 15 range selector switch to the OFF position before connecting or disconnecting the cable or detector.

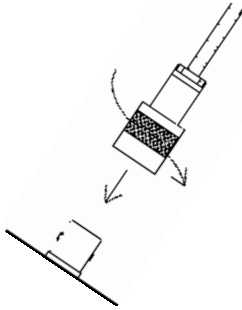

Connect one end of a detector cable to the desired detector by firmly pushing the connectors together while twisting clockwise a quarter of a turn. Repeat the process in the same manner with the other end of the cable and the instrument.

## Battery Test

The batteries should be checked each time the instrument is turned on. Move the range switch to the BAT position. Ensure that the meter needle deflects to the battery check portion on the meter scale. If the meter does not respond, check to see if the batteries have been correctly installed. Replace the batteries if necessary.

## Instrument Test

Connect the GM detector if you have not already done so. Set the B-G/N switch to B-G. After checking the batteries, turn the instrument range switch to the  $\times 1000$  position. Place the AUD ON-OFF switch in the ON position. Expose the detector to a radiation check source. The instrument speaker should emit "clicks" relative to the rate of counts detected. The AUD ON/OFF switch will silence the audible clicks if in the OFF position. It is recommended that the AUD ON/OFF switch be kept in the OFF position when not needed in order to preserve battery life.

Press the HV check button and confirm that the meter indicates approximately 900 volts (same as indicated on calibration test sheet). Rotate the range switch through the lower scales until a meter reading is indicated. Record the reading.

While observing the meter fluctuations, select between the fast and slow response time ("F/S") positions to observe variations in the display. The "S" position should respond approximately five times slower than the "F" position.

**Note:**

The slow response position is normally used when the instrument is displaying low numbers, which require a more stable meter movement. The fast response position is used at high rate levels.

Check the meter reset function by depressing the RES pushbutton switch and ensuring the meter needle drops to zero.

Turn the instrument off. Disconnect the GM detector and connect the neutron detector. Set the B-G/N switch to N. Press the HV check button and compare the high-voltage reading to the calibration test sheet reading (approximately 1275-1350 volts).

If a neutron source is available, expose the detector to the source (at a repeatable distance) and record the reading. Daily source checks may then be performed by orienting the detector and source in identical fashion, ensuring an instrument reading of  $\pm 20\%$  of the initial reading. Failure to meet the  $\pm 20\%$  criteria may indicate a detector malfunction.

Once this procedure has been completed, the instrument is ready for use.

## **Operational Check**

To assure proper operation of the instrument between calibrations and periods of nonuse, an instrument operational check including battery test and instrument test (as described above) should be performed prior to use.

**Section**  
**3**

## Specifications

---

**Instrument High Voltage:** adjustable independently from 200 to 2500 V; can be read on the meter; electronically regulated to 1%; support of scintillation loads to 1500 V and proportional loads to 2500 V

**Input Pulse Threshold:** adjustable from -2 to -60 mV

**Input Impedance:** 0.1 megohm

**Meter:** 6.4 cm (2.5 in.) arc, pivot-and-jewel suspension

**Meter Face:** 0-500 cpm, 0-2.5 kV, BAT TEST (others available)

**Instrument Range:** typically 0-500,000 cpm, depending on the meter face utilized

**Linearity:** reading within 10% of true value with detector connected

**Audio:** built-in unimorph speaker with ON-OFF switch (greater than 60 dB at 0.61 m {2 feet})

**Connector:** series "C" (other available)

**Power:** two "D" cell batteries housed in a sealed externally accessible compartment

**Battery Life:** typically 600 hours with alkaline batteries (battery condition may be checked on the meter)

**Battery Dependence:** instrument calibration changes less than 3% within battery check limits on the meter

**Size:** 31.8 x 8.9 x 21.6 cm (12.5 x 3.5 x 8.5 in.) (H x W x L)

**Weight:** 3.7 kg (8.1 lb), including batteries

**Construction:** cast-and-drawn aluminum with beige powder coating

**Cable:** 99.1 cm (39 in.) with "C" connector (other available)

**Model 42-14H  
Neutron Detector**

**Neutron Detector:** 2 Atm  $^3\text{He}$  tube, LND 25185 or equivalent; proportional detector with 7.6 cm (3 in.) diameter, cadmium-lined moderator for fast neutrons (remove detector from moderator for thermal neutrons)

**Neutron Detector Operating Voltage:** approximately 1275-1350 Vdc

**Energy Response:** count response nonlinear throughout energy spectrum (0.025-12 MeV)

**Neutron Sensitivity:** typically 55 cpm/mrem/hr ( $^{241}\text{AmBe}$  fast neutrons)

**Detection Range:** thermal to approximately 12 MeV

**Gamma Rejection:** typically 10 cpm or less through 10 R/hr (100 mSv/h) ( $^{137}\text{Cs}$ )

**Model 44-7 Alpha-Beta-  
Gamma Detector**

**Alpha-Beta-Gamma Detector:** thin end-window GM detector

**Window:**  $2.0 \pm 0.3$  mg/cm<sup>2</sup> mica

**Window Area:** active is 6.4 cm<sup>2</sup> (1 in<sup>2</sup>); open is 5.2 cm<sup>2</sup> (0.8 in<sup>2</sup>)

**Efficiency (4pi geometry):** typically 2% for  $^{14}\text{C}$ , 10% for  $^{90}\text{Sr}^{90}\text{Y}$ , 7% for  $^{239}\text{Pu}$ , and 7% for  $^{99}\text{Tc}$

**Alpha-Beta-Gamma Sensitivity:** typically 2100 cpm per mR/hr ( $^{137}\text{Cs}$  gamma)

**Background:** typically 40 cpm

## Section

## 4

## Identification of Controls and Functions

---

**Meter:** 6.4 cm (2.5 in.) arc, 1 mA analog type with pivot-and-jewel suspension. Typical meter dial is 0-500 cpm, 0-2.5 kV and BAT TEST.

**Connector:** used to connect the detector to the instrument. Typically series "C," but can be "BNC," "MHV," "UHF," or others.

**Range Selector Switch:** a six-position switch marked OFF, BAT,  $\times 1000$ ,  $\times 100$ ,  $\times 10$ , and  $\times 1$ . Turning the range selector switch from OFF to BAT provides the operator with a battery check of the instrument. A BAT TEST scale on the meter provides a visual means of checking the battery-charge status. Moving the range selector switch to one of the range multiplier positions ( $\times 1000$ ,  $\times 100$ ,  $\times 10$ ,  $\times 1$ ) provides the operator with an overall range of 0 to 500,000 cpm. Multiply the scale reading by the multiplier to determine the actual scale reading.

**Battery Compartment:** sealed compartment to house two "D" cell batteries.

**AUD ON-OFF Toggle Switch:** in the ON position, operates the unimorph speaker, located on the left side of the instrument. The frequency of the clicks is relative to the rate of the incoming pulses. The higher the rate, the higher the audio frequency. This switch should be turned OFF when not required, in order to reduce battery drain.

**RES Pushbutton:** When depressed, this button provides a rapid means of driving the meter needle to zero.

**F/S Toggle Switch:** provides meter response. Selecting the fast, "F" position, of the toggle switch provides 90% of full-scale meter deflection in four seconds. In the slow, "S" position, 90% of full-scale meter deflection takes 22 seconds. In the "F" position there is fast response and large meter deviation. The "S" position should be used for slow response and damped meter deviation.

**B-G/N:** This switch allows for selection of the desired detector and is associated with the HV outputs. In the B-G position, the HV is adjusted for approximately 900 volts for use with GM detectors. In the N position, the HV is adjusted for approximately 1275-1350 volts when utilizing the Model 42-14H Neutron detector.

**HV Pushbutton Switch:** When depressed, displays the detector high voltage on the meter face, corresponding to the selected detector (B-G/N). The output resistance of the high-voltage supply is 1.5 megohms with a typical scintillation voltage divider of 100 megohms. The actual detector voltage will be 98.5% of the indicated voltage.

**The following controls are located under the front-panel calibration cover:**

**Discriminator Adjustment (DIS):** allows the input pulse threshold to be adjusted from 2 to 60 mV.

**HVB Adjustment:** provides a means of varying the alpha-beta-gamma high voltage from 200 to 2500 V; factory set at 900 V

**Range Calibration Adjustments:** These adjustment controls allow individual calibration for each range multiplier.

**Section****5**

## Safety Considerations

---

### Environmental Conditions for Normal Use

Indoor or outdoor use

No maximum altitude

Temperature range of -20 to 50 °C (-4 to 122 °F); may be certified for operation from -40 to 65 °C (-40 to 150 °F)

Maximum relative humidity of less than 95% (non-condensing)

Pollution Degree 3 (as defined by IEC 664) (Occurs when conductive pollution or dry nonconductive pollution becomes conductive due to condensation. This is typical of industrial or construction sites.)

### Warning Markings and Symbols

**Caution!**

The operator or responsible body is cautioned that the protection provided by the equipment may be impaired if the equipment is used in a manner not specified by Ludlum Measurements, Inc.



**The Model 15 Neutron Counter is marked with the following symbols:**



**CAUTION, RISK OF ELECTRIC SHOCK** (per ISO 3864, No. B.3.6) – designates a terminal (connector) that allows connection to a voltage exceeding 1 kV. Contact with the subject connector while the instrument is on or shortly after turning off may result in electric shock. This symbol appears on the front panel.



**CAUTION** (per ISO 3864, No. B.3.1) – designates hazardous live voltage and risk of electric shock. During normal use, internal components are hazardous live. This instrument must be isolated or disconnected from the hazardous live voltage before accessing the internal components. This symbol appears on the front panel. **Note the following precautions:**

#### **Warning!**

The operator is strongly cautioned to take the following precautions to avoid contact with internal hazardous live parts that are accessible using a tool:

1. Turn the instrument power OFF and remove the batteries.
2. Allow the instrument to sit for one minute before accessing internal components.



The “**crossed-out wheelie bin**” symbol notifies the consumer that the product is not to be mixed with unsorted municipal waste when discarding; each material must be separated. The symbol is placed on the battery compartment lid. See section 9, “Recycling,” for further information.



The “CE” mark is used to identify this instrument as being acceptable for use within the European Union.

## **Cleaning and Maintenance Precautions**

The Model 15 instrument and associated detectors may be cleaned externally with a damp cloth, using only water as the wetting agent. Do not immerse the instrument in any liquid. Observe the following precautions when cleaning or performing maintenance on the instrument:

1. Turn the instrument OFF and remove the batteries.
2. Allow the instrument to sit for one minute before cleaning the exterior or accessing any internal components for maintenance.

**Section****6**

## Calibration and Maintenance

---

### Calibration

Calibration controls are located on the front of the instrument under the calibration cover. The controls may be adjusted with a 1/8-inch blade screwdriver.

**Note:**

Measure high voltage with a Ludlum Model 500 Pulser or a high-impedance voltmeter with a high-meg probe. If one of these instruments is not available, use a voltmeter with a minimum input resistance of 1000 megohms.

### Calibration of Discriminator

Set the instrument range switch to X10. Remove the calibration cover plate. Connect the Model 15 to the Model 500 Pulser. Set the pulser's pulse height to  $10 \pm 0.5$  mV for use without a GM detector. If a GM detector is used, set the pulse height to  $30 \pm 0.5$  mV. Set the pulser's pulse rate to  $400 \times 10$  counts per minute.

Adjust the DIS control until the meter reading increases from 0 to a stable reading near 400 counts per minute. Check the adjustment by lowering the Model 500 pulser's pulse height to 9 mV for 10 mV setting or 29 mV for 30 mV setting. Meter reading should drop to 0. Increase the Model 500 pulse height to 12 mV for a 10 mV DIS setting or 32 mV for a 30 mV DIS setting. Meter reading should increase to a stable value near 400 counts per minute.

### Calibration of Ratemeter

Set the Range switch to X1000. Set the pulser's pulse rate to  $400 \times 1K$  counts per minute. Set the pulser's pulse height to 20 mV for a DIS setting of 10 mV or 60 mV for a DIS setting of 30 mV.

Now adjust the X1000 calibration potentiometer until the Model 15 reads  $400 \times 1000$  counts/minute. Reduce the pulser's pulse rate to  $100 \times 1K$  counts per minute. Confirm that meter reading is  $100 \pm 10$ .

Set the pulser's pulse rate to  $400 \times 100$  counts per minute. Set the Model 15 range switch to X100. Adjust the X100 calibration potentiometer until the Model 15 reads  $400 \times 100$  counts per minute. Reduce the counts on Pulser to  $100 \times 100$  counts per minute and confirm that the Model 15 reads  $100 \pm 10$ . Repeat the procedure for the X10 and X1 ranges.

### Calibration of High Voltage Readout

Open the instrument and locate the HV calibration control on the main circuit board. Connect the Model 15 to the Model 500 Pulser. Set the B-G/N switch to N. Press the HV Test switch and record the HV reading on both the Model 500 and the Model 15.

Adjust the HVN potentiometer for 1500 V on pulser readout. Press the HV button and adjust the internal Model 15 HV control until the meter reads 1500 V. Reduce the HVN control for 1000 V on pulser HV readout. HV test should indicate  $1000 \pm 10\%$ . Increase the HVN control to 2000 V on Pulser HV readout. HV test should indicate  $2000 \pm 10\%$  V.

### Calibration of High Voltage

(For Beta Gamma Set B-G/N to B-G.) Press the HV test switch and adjust the HVB calibration potentiometer for a reading of 900 V.

### Calibration of High Voltage For Neutrons

Switch the B-G/N switch to N. Connect the neutron probe. Press the HV test switch. Record readings in a known neutron field as the high voltage is varied from approximately 1200-1500 V in 50 V steps.

Expose Neutron detector to a 1 R/hr gamma field. Reduce the high-voltage setting until count rate is less than 10 counts per minute.

Plot the data from the previous two steps. Pick an operating point just above the knee of the count plateau, but at a voltage less than the Gamma cutoff found in the previous step. Record this voltage and adjust the HVN calibration potentiometer for operation at this voltage.

### Efficiency Calibration

With the instrument fully calibrated, set the B-G/N switch to N. Connect the neutron detector within the moderator. Expose the detector to a known neutron field and determine counts/minute per mrem/hr for that energy source. Note that the Model 15 is energy dependent.

Repeat the above procedure with the B-G/N switch in the B-G position and the gamma detector connected and exposed to a known gamma field. Determine counts/minute per mR/hr.

## Maintenance

Instrument maintenance consists of keeping the instrument clean and periodically checking the batteries and the calibration. The Model 15 instrument may be cleaned with a damp cloth (using only water as the wetting agent). Do not immerse instrument in any liquid. Observe the following precautions when cleaning:

1. Turn the instrument OFF and remove the batteries.
2. Allow the instrument to sit for one minute before accessing internal components.

### Recalibration

Recalibration should be accomplished after maintenance or adjustments have been performed on the instrument. Recalibration is not normally required following instrument cleaning, battery replacement, or detector cable replacement of equal length.

#### Note:

Ludlum Measurements, Inc. recommends recalibration at intervals no greater than one year. Check the appropriate regulations to determine required recalibration intervals.

Ludlum Measurements offers a full-service repair and calibration department. We not only repair and calibrate our own instruments but most other manufacturers' instruments. Calibration procedures are available upon request for customers who choose to calibrate their own instruments.

### **Batteries**

The batteries should be removed any time the instrument is placed into storage. Battery leakage may cause corrosion on the battery contacts, which must be scraped off and/or washed using a paste solution made from baking soda and water. Use a spanner wrench to unscrew the battery contact insulators, exposing the internal contacts and battery springs. Removal of the handle will facilitate access to these contacts.

#### **Note:**

Never store the instrument over 30 days without removing the batteries. Although this instrument will operate at very high ambient temperatures, battery seal failure may occur at temperatures as low as 37 °C (100 °F).

---

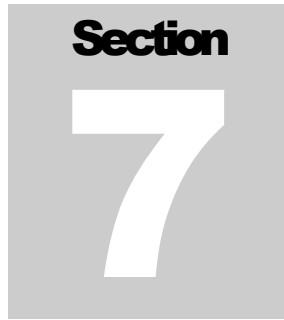
 A gray square containing the word "Section" in a bold, black, sans-serif font at the top, and a large, white, bold number "7" in the center.

## Troubleshooting

---

Occasionally, you may encounter problems with your LMI instrument or detector that may be repaired or resolved in the field, saving turn-around time and expense in returning the instrument to us for repair. Toward that end, LMI electronics technicians offer the following tips for troubleshooting the most common problems. Where several steps are given, perform them in order until the problem is corrected. Keep in mind that with this instrument, the most common problems encountered are: (1) detector cables, (2) sticky meters, and (3) battery contacts.

Note that the first troubleshooting tip is for determining whether the problem is with the electronics or with the detector. A Ludlum Model 500 Pulser is invaluable at this point, because of its ability to simultaneously check high voltage, input sensitivity or threshold, and the electronics for proper counting.

We hope these tips will prove to be helpful. As always, please call if you encounter difficulty in resolving a problem or if you have any questions.

### Troubleshooting the Electronics

<u>SYMPTOM</u>	<u>POSSIBLE SOLUTION</u>
No power (or meter does not reach BAT TEST or BAT OK mark)	<ol style="list-style-type: none"> <li>1. Check batteries and replace if weak.</li> <li>2. Check polarity (see marks inside battery lid). Are the batteries installed backwards?</li> </ol>

<b><u>SYMPTOM</u></b>	<b><u>POSSIBLE SOLUTION</u></b>
No power (or meter does not reach BAT TEST or BAT OK mark) (continued)	<ol style="list-style-type: none"><li>3. Check battery contacts. Clean them with rough sandpaper or use an engraver to clean the tips.</li><li>4. Check for loose or broken wires, especially between the main board and the high-voltage board.</li></ol>
Nonlinear Readings	<ol style="list-style-type: none"><li>1. Check the high voltage (HV) by pressing the HV TEST button. If a multimeter is used to check the HV, ensure that one with high impedance is used, as a standard multimeter could be damaged in this process.</li><li>2. Check for noise in the detector cable by disconnecting the detector, placing the instrument on the lowest range setting, and wiggling the cable while observing the meter face for significant changes in readings.</li><li>3. Check for “sticky” meter movement. Does the reading change when you tap the meter? Does the meter needle “stick” at any spot?</li><li>4. Check the “meter zero.” Turn the power OFF. The meter should come to rest on zero.</li></ol>
Meter goes full-scale or “pegs out”	<ol style="list-style-type: none"><li>1. Replace the detector cable to determine whether or not the cable has failed, causing excessive noise.</li><li>2. Check the HV and, if possible, the input threshold for proper setting.</li></ol>

<u>SYMPTOM</u>	<u>POSSIBLE SOLUTION</u>
Meter goes full-scale or “pegs out” (continued)	<ol style="list-style-type: none"><li>3. Ensure that the instrument’s can is properly attached. When attached properly, the speaker will be located on the left side of the instrument. If the can is on backwards, interference between the speaker and the input preamplifier may cause noise.</li></ol>
No Response to Radiation	<ol style="list-style-type: none"><li>1. Substitute a “known good” detector and/or cable.</li><li>2. Has the correct operating voltage been set? Refer to the calibration certificate or detector instruction manual for correct operating voltage. If the instrument uses multiple detectors, confirm that the high voltage is matched to the current detector being used.</li></ol>
No Audio	<ol style="list-style-type: none"><li>1. Ensure that the AUD ON-OFF switch is in the ON position.</li><li>2. Remove the instrument housing and check the connection between the circuit board and the speaker. Plug in the two-pin connector if necessary.</li></ol>



**Section****8**

## Technical Theory of Operation

---

### Input

Detector pulses are coupled from the detector through C57 to emitter follower Q96. R83, 89 provide bias. R137 protects Q96 from input shorts. R27 couples the detector to the high-voltage supply.

### Amplifier

A self-biased amplifier provides gain in proportion to R63 divided by R70. Transistor U1 provides amplification. U8 functions as a current mirror to provide a load to U10. The output self-biases to  $2 V_{be}$  (approximately 1.4 V), providing just enough bias current to conduct all of the current from the current mirror.

Positive pulses from U10 are coupled to the discriminator.

### Discriminator

Comparator U2 provides discrimination. The discriminator is set by the DIS (discriminator) control located on the front panel, coupled to pin 3 of U2. These pulses are coupled to pin 5 of U3 for meter drive and pin 12 of U3 for audio.

### Audio

Discriminator pulses are coupled to univibrator pin 12 of U3. Front-panel audio ON-OFF selector controls the reset at pin 13 of U4. When ON, pulses from pin 10 of U3 turns on oscillator U5, which drives the can mounted unimorph through Q149 and T136. Speaker tone is set by R84, C112; duration by R86.

## Digital Analog Converter

Pin 12, 15 of U4 are coupled as a current mirror. For each pulse of current through R72, and equal current is delivered to C105. This charge is drained off by R74. The voltage across C105 is proportional to the incoming count rate.

## Scale Ranging

Detector pulses from the discriminator are coupled to univibrator pin 5 of U3. For each scale, the pulse width of pin 6 of U3 is increased by a factor of 10 with the actual pulse width being controlled by the front-panel calibration controls and their related capacitors. This arrangement allows the same current to be delivered to C105 by one count on the X1 range as 1000 counts on X1K range.

## Meter Drive

The meter is driven by the emitter to Q6, coupled as a voltage follower in conjunction with pin 1 of U6. For ratemeter drive, the meter is coupled to C105 at P1 15.

For high voltage, the meter is coupled to R132 at P1 11.

For battery test, the voltage follower is bypassed and the meter movement is directly coupled to the battery through R150.

## Meter Compensation

When the unit is provided with a high torque meter movement, with 1.2 V drive, a temperature compensation package may be located at the meter, internal or external.

## Fast / Slow Time Constant

For slow time constant, C104 is switched from the output of the meter drive to parallel C105.

## Low Voltage Supply

Battery voltage is coupled to U7 and associated components (a switching regulator) to provide 5 V at pin 5 to power all logic circuits. Unregulated battery voltage is used to power the meter drive (Q6) and the high voltage blocking oscillator Q145.

## Low Voltage Reference

U101 provides a 1.22 V precision reference for HV supply. This unit also biases Q96.

## High Voltage Supply

High voltage is developed by blocking oscillator Q145-T165 and rectified by voltage multiplier CR166, 167, 169, and 175. Output voltage increases as current through Q44 increases, with maximum output voltage with Q44 saturated.

High voltage is coupled back through R47, R90 to opamp pin 6 of U6. R147 completes the high-voltage circuit-to-ground. High-voltage output is set by front-panel control HV, which sets bias of pin 5 of U6. During stable operation, the voltage at pin 6 of U6 will equal the voltage at pin 5 of U6. Pin 7 of U6 will cause conduction of Q44 to increase or decrease until the high voltage seeks a level for stability.

## Section

## 9

## Recycling

Ludlum Measurements, Inc. supports the recycling of the electronics products it produces for the purpose of protecting the environment and to comply with all regional, national, and international agencies that promote economically and environmentally sustainable recycling systems. To this end, Ludlum Measurements, Inc. strives to supply the consumer of its goods with information regarding reuse and recycling of the many different types of materials used in its products. With many different agencies – public and private – involved in this pursuit, it becomes evident that a myriad of methods can be used in the process of recycling. Therefore, Ludlum Measurements, Inc. does not suggest one particular method over another, but simply desires to inform its consumers of the range of recyclable materials present in its products, so that the user will have flexibility in following all local and federal laws.

The following types of recyclable materials are present in Ludlum Measurements, Inc. electronics products, and should be recycled separately. The list is not all-inclusive, nor does it suggest that all materials are present in each piece of equipment:

Batteries	Glass	Aluminum and Stainless Steel
Circuit Boards	Plastics	Liquid Crystal Display (LCD)

Ludlum Measurements, Inc. products that have been placed on the market after August 13, 2005 have been labeled with a symbol recognized internationally as the “crossed-out wheelie bin.” This notifies the consumer that the product is not to be mixed with unsorted municipal waste when discarding; each material must be separated. The symbol will be placed near the AC receptacle, except for portable equipment where it will be placed on the battery lid.

The symbol appears as such:



# Section 10

## Parts List

	<u>Reference</u>	<u>Description</u>	<u>Part Number</u>
<b>Model 15 Neutron Counter with Detectors</b>	UNIT	Completely Assembled Model 15 Neutron Counter With Detectors	48-1614
<b>Main Board, Drawing 464 x 655</b>	BOARD	Completely Assembled Main Circuit Board	5464-655
CAPACITORS	C38	0.0047 $\mu$ F, 3kV	04-5547
	C40-C42	0.0047 $\mu$ F, 3kV	04-5547
	C50	100pF, 3kV	04-5532
	C56	100 $\mu$ F, 10V	04-5576
	C57	100pF, 3kV	04-5532
	C102	100 $\mu$ F, 10V	04-5576
	C103	10 $\mu$ F, 20V	04-5592
	C104	100 $\mu$ F, 10V	04-5576
	C105	22 $\mu$ F, 35V	04-5594
	C106	0.001 $\mu$ F, 100V	04-5519
	C109	0.01 $\mu$ F, 100V	04-5523
	C111	0.01F, 100V	04-5523
	C112	470pF, 100V	04-5555
	C113	0.01 $\mu$ F, 100V	04-5523
	C115	0.01 $\mu$ F, 100V	04-5523
	C117	47pF, 100V	04-5533
	C119	0.001 $\mu$ F, 100V	04-5519
	C121	330pF, 100V	04-5531
	C122	0.0047F, 3kV	04-5547
	C126	10 $\mu$ F, 20V	04-5592
C134	100 $\mu$ F, 10V	04-5576	
C163	0.01 $\mu$ F, 100V	04-5523	
C170	0.1 $\mu$ F, 100V	04-5521	
C171	1 $\mu$ F, 35V	04-5575	

	<u>Reference</u>	<u>Description</u>	<u>Part Number</u>
	C176	0.0047 $\mu$ F, 3kV	04-5547
	C178	0.1 $\mu$ F, 100V	04-5521
	C179	0.01 $\mu$ F, 100V	04-5523
TRANSISTORS	Q6	2N3904G	05-5755
	Q15	2N4402BU	05-5763
	Q44	2N3904G	05-5755
	Q96	2N3904G	05-5755
	Q145	MPSW51AG	05-5765
INTEGRATED CIRCUITS	U1	CMXT3904TRLF	05-5890
	U2	TLC372	06-6265
	U3	CD4098	06-6066
	U4	CMXT3904TRLF	05-5888
	U5	ICM7555	06-6136
	U6	TLC27M7IP	06-6248
	U7	MAX631	06-6249
	U8	CMXT3904TRLF	05-5890
	U9-U10	CMXT3904TRLF	05-5888
	U101	LM385Z-1.2	05-5808
DIODES	CR94	1N4148	07-6272
	CR166-CR167	GI250-2	07-6266
	CR169	GI250-2	07-6266
	CR175	GI250-2	07-6266
THERMISTORS	RT1-RT2	150 OHM	07-6332
POTENTIOMETER / TRIMMER	R132	1M	09-6814
RESISTORS	R3	634 OHM	12-7808
	R18	1k	10-7009
	R27	1 MEG	10-7028
	R28	4.7 MEG	10-7030
	R36	1 MEG	10-7028
	R46	10k	10-7016
	R47-R48	1G	12-7686
	R63	82k	10-7022
	R64	1k	10-7009
	R65	10k	10-7016
	R66	1k	10-7009

	<u>Reference</u>	<u>Description</u>	<u>Part Number</u>
	R68	8.2k	10-7015
	R70	4.7k	10-7014
	R72	10K	10-7016
	R74	82k	10-7022
	R75	33k	10-7019
	R76	100 OHM	10-7004
	R77	2.2k	10-7012
	R78	22k	10-7070
	R79	100k	10-7023
	R81	10k	10-7016
	R83	100k	10-7023
	R84	470k	10-7026
	R86	2.7 MEG	10-7029
	R87	10k	10-7016
	R89-R90	100k	10-7023
	R91	4.7k	10-7014
	R128	100k	10-7023
	R137	10k	10-7016
	R138	1 MEG	10-7028
	R147	432k	12-7689
	R150	2.37k	12-7648
	R159	10k	10-7016
	R172	47k	10-7020
	R177	200 OHM	10-7006
CONNECTORS	P1	CONN-1-640456-6 MTA100X16	13-8134
	P2	CONN-640456-2 MTA100X2	13-8073
	W2-W29	CLOVERLEAF RECEPTACLE	18-8771
INDUCTOR	L13	470uH	21-9600
TRANSFORMER	T165	T165	40-0902
<b>Calibration Board, Drawing 363 × 585</b>	BOARD	Completely Assembled Calibration Board	5363-735
CAPACITORS	C1	0.047 $\mu$ F, 100V	04-5565
	C2	0.0047 $\mu$ F, 100V	04-5570

	<u>Reference</u>	<u>Description</u>	<u>Part Number</u>
POTENTIOMETERS	R1	1 MEG, ×1	09-6814
	R2	1 MEG, ×10	09-6814
	R3	1 MEG, ×100	09-6814
	R4	100k, × 1000	09-6813
	R5	100k, HV NEUTRON	09-6813
	R6	100k, HV BETA/GAMA	09-6813
	R7	100k, DISCRIMINATOR (DIS)	09-6813
RESISTORS	R8	47k	10-7020
	R9	1k	12-7750
RESISTOR NETWORK	RN1	10k SIP 8P	12-7720
CONNECTORS	P3	CONN-640456-6 MTA100	13-8095
	P4	CONN-640456-4 MTA100	13-8088
<b>Wiring Diagram, Drawing 363 × 587</b> CONNECTORS	J1	CONN-1-640442-6	13-8187
	J2	CONN-640442-2 MTA100	13-8178
	J3	CONN-640442-6 MTA100	13-8171
	J4	CONN-640442-4 MTA100	13-8170
	J5	RECPT-UG706/U SCREW IN "C"	13-7751
AUDIO	DS1	UNIMORPH, TEC-3526-PU	21-9251
BATTERIES	B1-B2	"D" CELL BATTERY	21-9313
SWITCHES	S1	PA-600-210	08-6501
	S2	#923 SWITCHCRFT	08-6518
	S3	30-1-PB	08-6517
	S4-S6	7101-SYZ-QE	08-6511
METER	M1	PORT BEZEL W/ MVMNT ASSY	4363-188



---

	<u>Reference</u>	<u>Description</u>	<u>Part Number</u>
MISCELLANEOUS	*	METER MOVEMENT (1mA)	15-8030
	*	PORT LATCH KIT W/O BATT. LID	4363-349
	*	PORT HANDLE (ROLLED) W/SCREWS	7363-139
	*	PORT HANDLE FOR CLIP W/SCREWS	7363-203
	*	REPLACEMENT CABLE (STD 39 inch)	40-1004
	*	CLIP (44-3 TYPE) W/SCREWS	7002-026-01
	*	CLIP (44-7 TYPE) W/SCREWS	7010-007-01
	*	CLIP (44-6 TYPE) W/SCREWS	7010-008-01
DETECTORS	*	MODEL 44-7 END WINDOW GM PROBE	47-1536
	*	MODEL 15 MODERATOR W/ 42-14H NEUTRON PROBE	47-1575

**Section**  
**11**

## **Drawings and Diagrams**

---

MAIN CIRCUIT BOARD (with Temperature Compensation),  
Drawing 464 × 655

MAIN CIRCUIT BOARD LAYOUT, Drawing 464 × 658 (2 sheets)

CALIBRATION BOARD, Drawing 363 × 585

CALIBRATION BOARD LAYOUT, Drawing 363 × 586 (2 sheets)

WIRING DIAGRAM, Drawing 363 × 587

MODEL 42-14H DETECTOR ASSEMBLY, Drawing 204 × 16

MODEL 44-7 DETECTOR ASSEMBLY, Drawing 2 × 157

MODEL 44-7 ENERGY RESPONSE CURVE

### Ludlum Model 44-7 (Side-on Calibration)

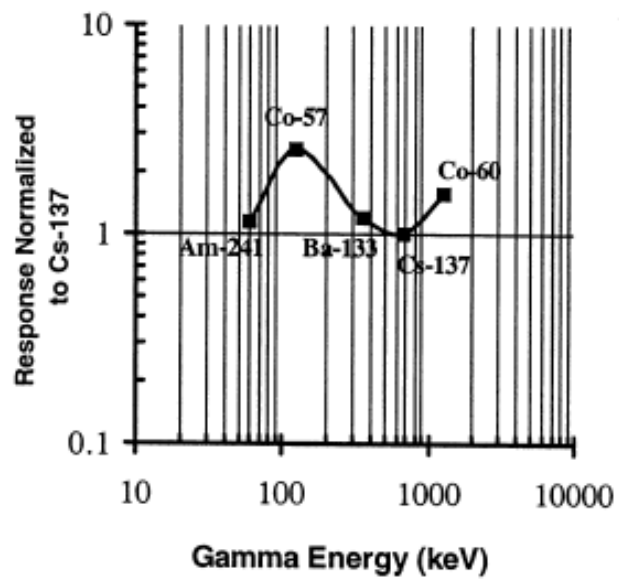

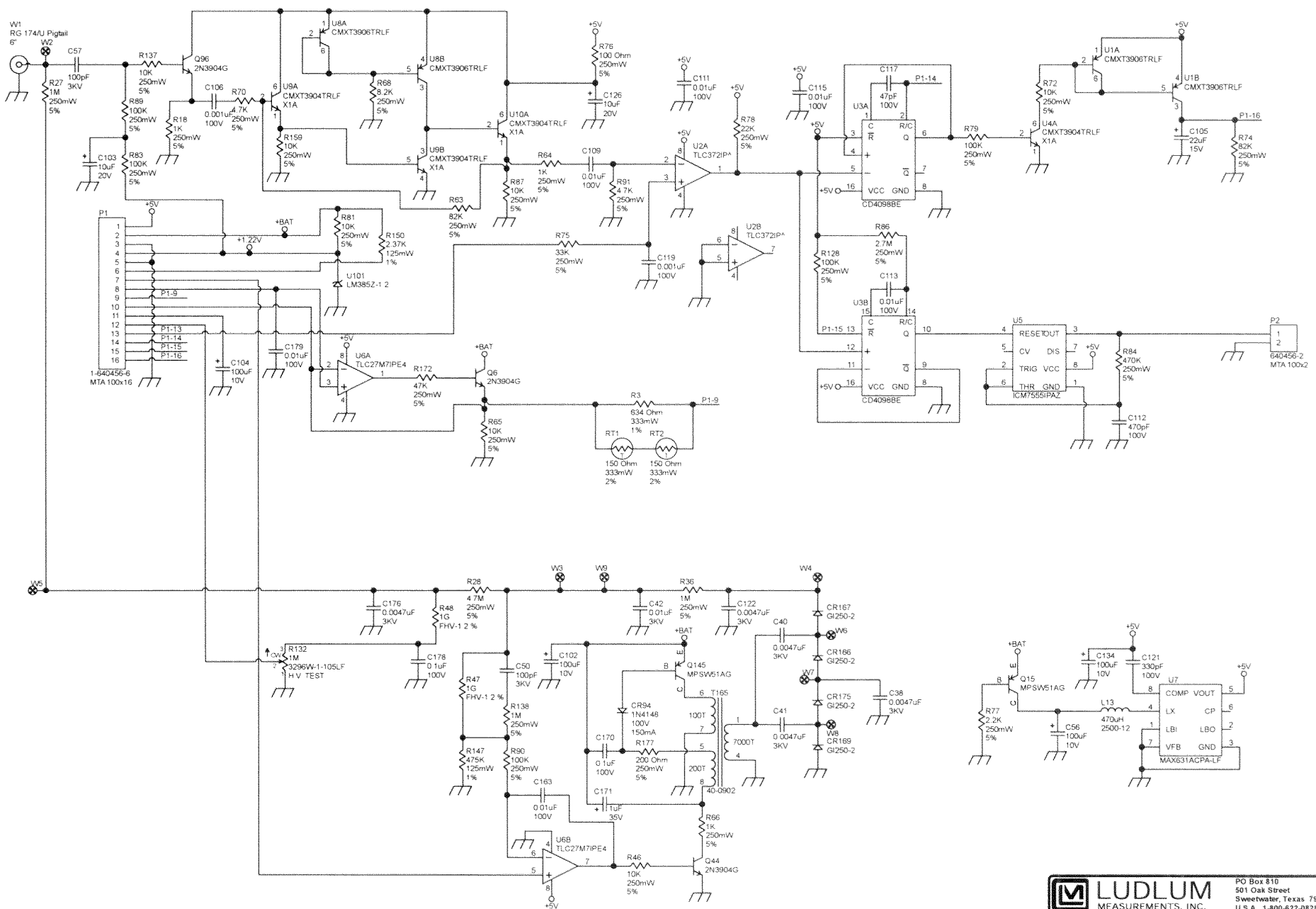

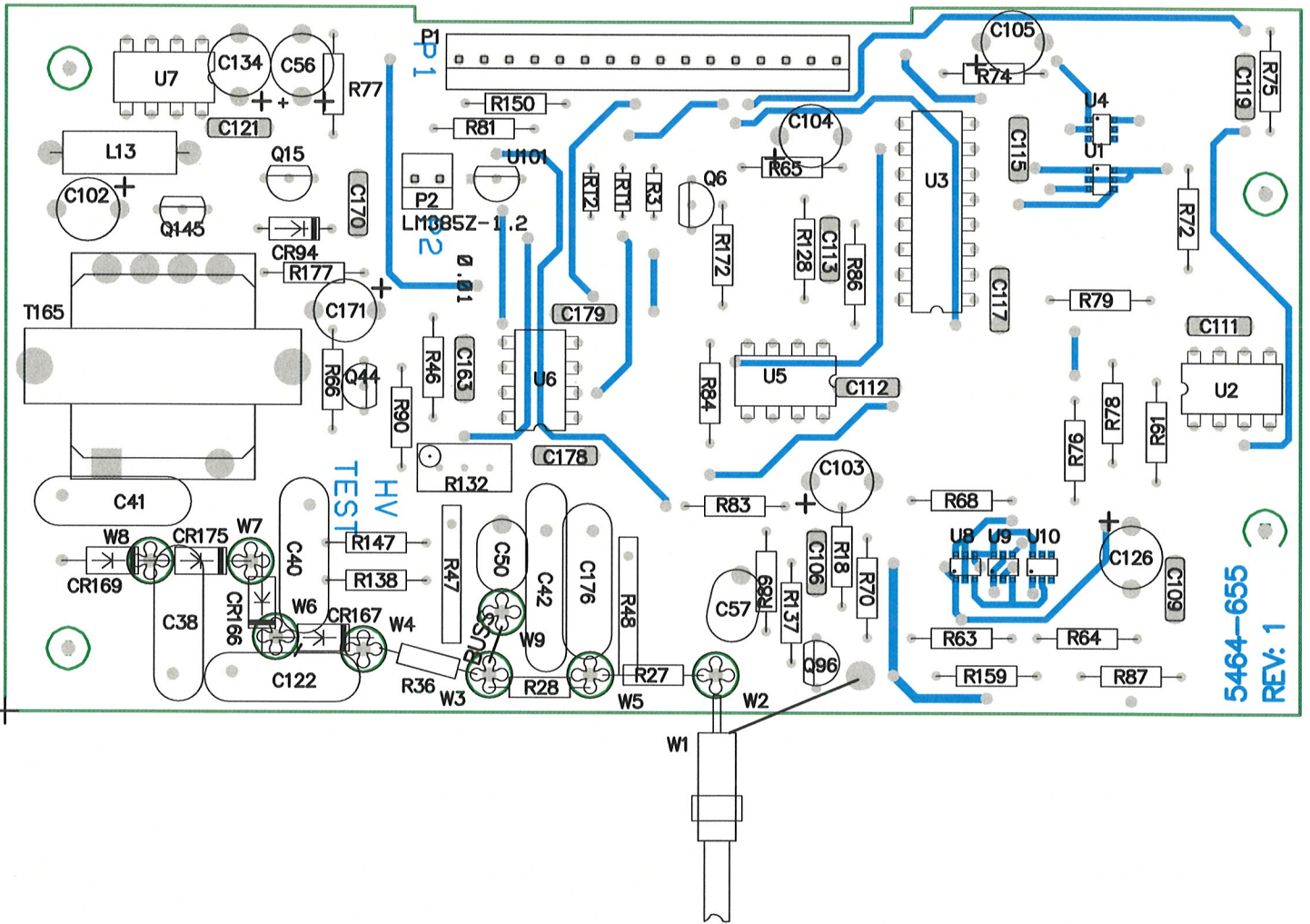

		PO Box 810 501 Oak Street Sweetwater, Texas 79556 U.S.A. 1-800-622-0828	
Drawn: PAB	4/15/2020	Title: MAIN W/TEMP	
Design: DL	6/1/1990	Model: 15	
		Board#: 5464-655	
Approved: [Signature]		Sheet: 1 of 1	Series: 464
Print Date: 4/15/2020 11:13:33 AM	Rev: 1		Sheet: 655

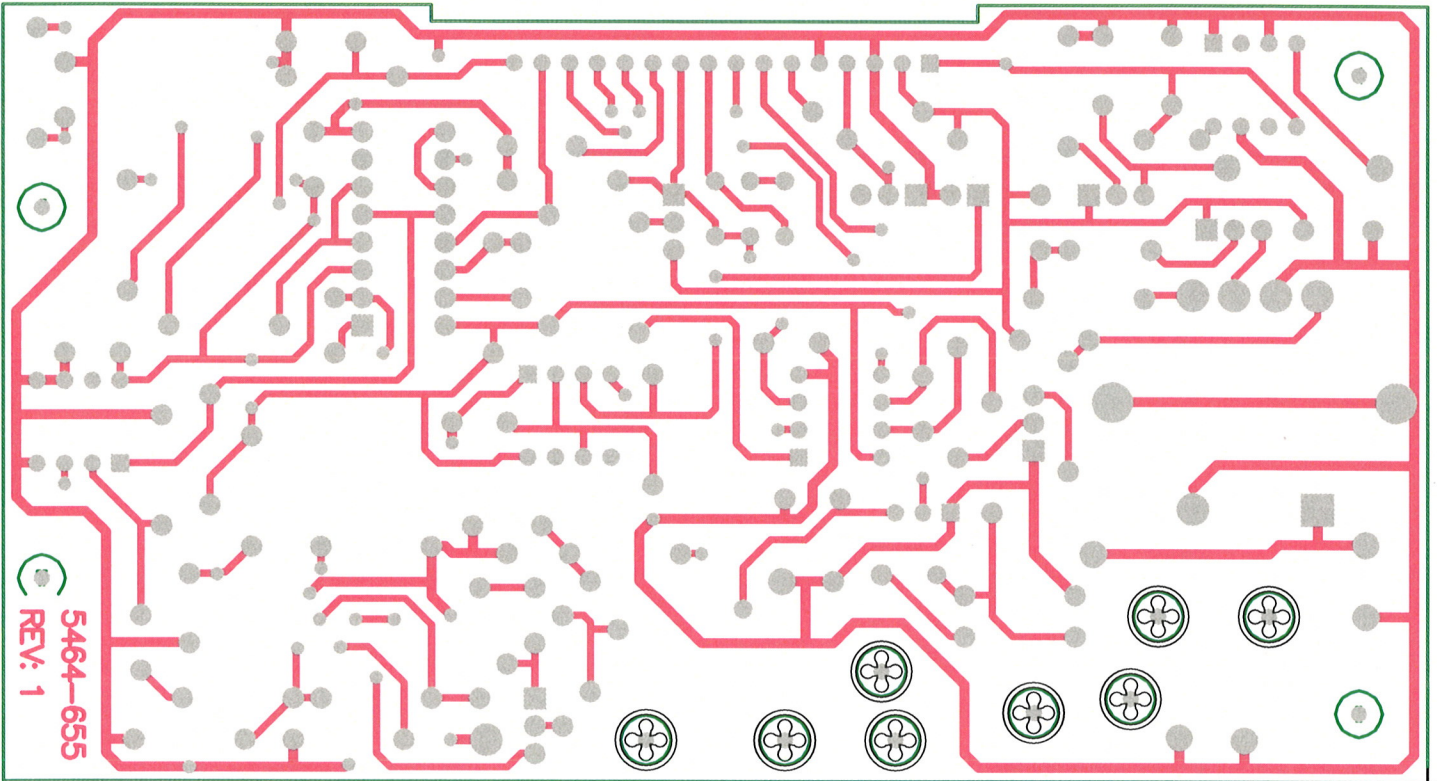

5464-655  
REV: 1

		PO Box 810 501 Oak Street Sweetwater, TX 79556 U.S.A. 1-800-622-0828	
		<b>Title:</b> MAIN W/TEMP	
<b>Drawn:</b> PAB	4/15/2020	<b>Model:</b> 15	
<b>Design:</b> DL	6/1/1990	<b>Board#:</b> 5464-655	
<b>Approve:</b> JMC	4/16/2020	<b>Rev:</b> 1	
<b>PCBA Drawing</b>		<b>SCALE:</b> 1.05	<b>Series</b>
<b>Print Date:</b> 4/16/2020	11:03:27 AM	Top Overlay	<b>Sheet</b> 464 658
<small>\\freedom\pcb\Projects\LMM 15\5464-655\Rev1\464655R1_Assy.PcbDoc</small>			



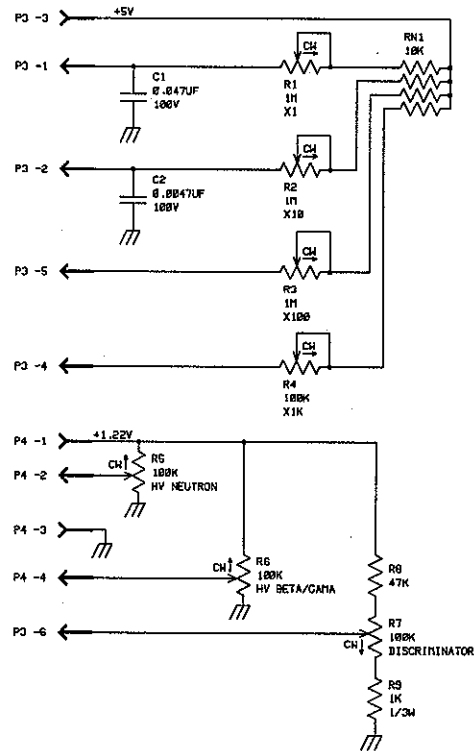

 <b>LUDLUM MEASUREMENTS, INC.</b>		PO Box 810 501 Oak Street Sweetwater, TX 79556 U.S.A. 1-800-622-0828		
		<b>Title:</b> MAIN W/TEMP		
<b>Drawn:</b> PAB	4/15/2020	<b>Model:</b> 15		
<b>Design:</b> DL	6/1/1990	<b>Board#:</b> 5464-655		
<b>Approve:</b> JMC	4/16/2020	<b>Rev:</b> 1		
<i>PCBA Drawing</i>		<b>SCALE:</b> 1.05	<b>Series</b>	<b>Sheet</b>
<b>Print Date:</b> 4/16/2020	11:03:31 AM	Bottom Overlay	464	658
<small>\\freedom\pcb\Projects\L\MIM 19\5464-655\Rev1\464655R1_Assy.PcbDoc</small>				

REVISIONS				
EFF	AUTHORITY	ZONE	LTR	APPROVED



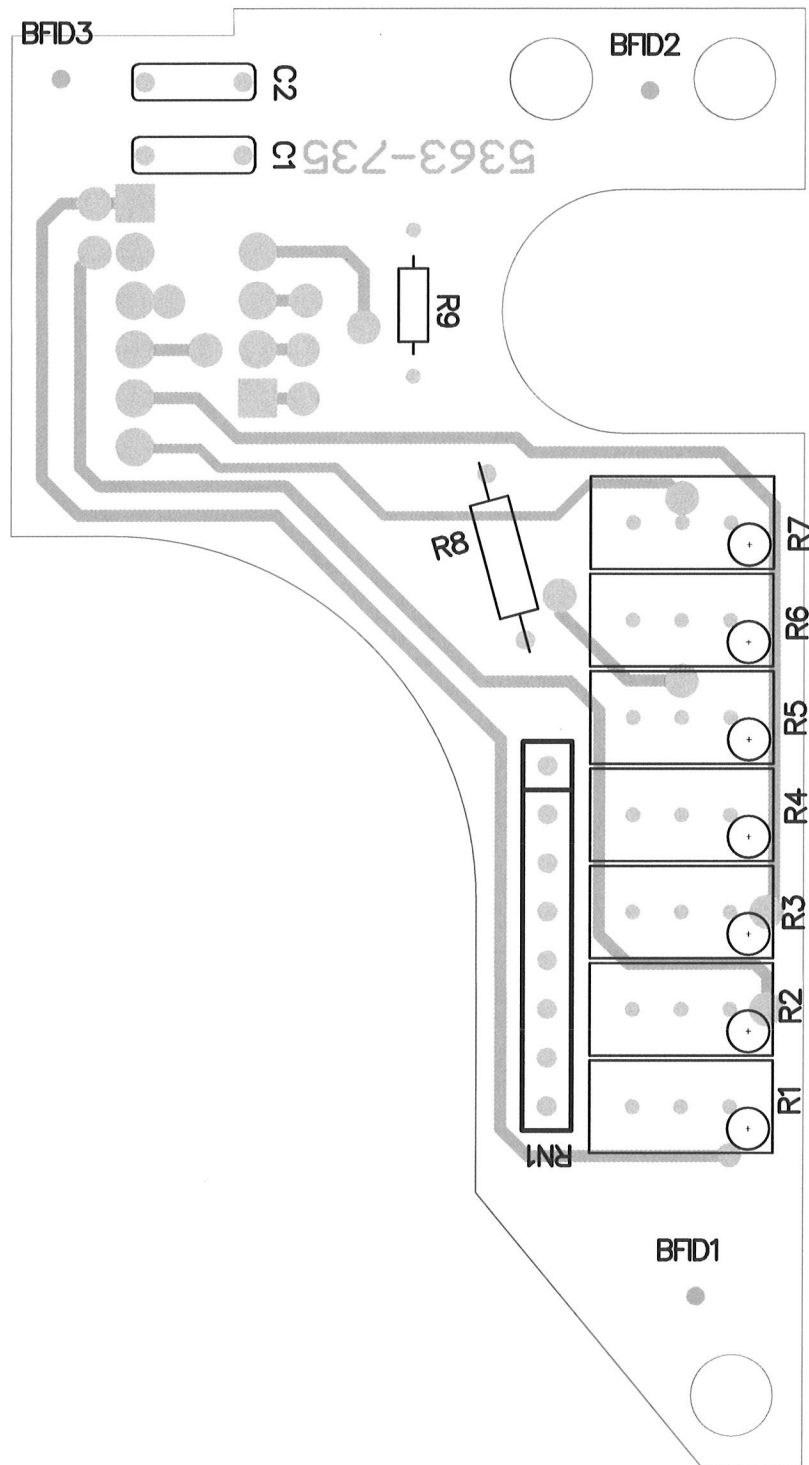

UPDATED	-	/ /	LUDLUM MEASUREMENTS INC.			
DR CKD		03/22/92	TITLE: CALIBRATION BOARD			
CHK	<i>JDW</i>	<i>11/16/92</i>	BOARD# 5363-735			
DISCH	-	/ /	SIZE	MODEL	SERIES	SHEET
APPD	<i>JDW</i>	<i>11/16/92</i>	D	15	363	606
NEXT HIGHER ASSY.	-					
11:24:27		23-Sep-93	SB363735			SHEET 1 OF 1



 <b>LUDLUM</b> <b>MEASUREMENTS, INC.</b>		PO Box 810 501 Oak Street Sweetwater, TX 79556 U.S.A. 1-800-622-0828	
Title: CALIBRATION BOARD			
Drawn: CKB	09/23/92	Model: 15	
Design: Initials	MM/DD/YY	Board#: 5363-735	
Approve: <i>RAS</i>	<i>24NOV14</i>	Rev: 2	
PCBA Drawing		SCALE: 1.05	Series Sheet
Print Date: 11/20/2014 1:13:08 PM		Top Overlay	363 586
<small>W:\Projects\LMIM 15\5363-735\Rev2\363735R2_Assy_PcbDoc</small>			

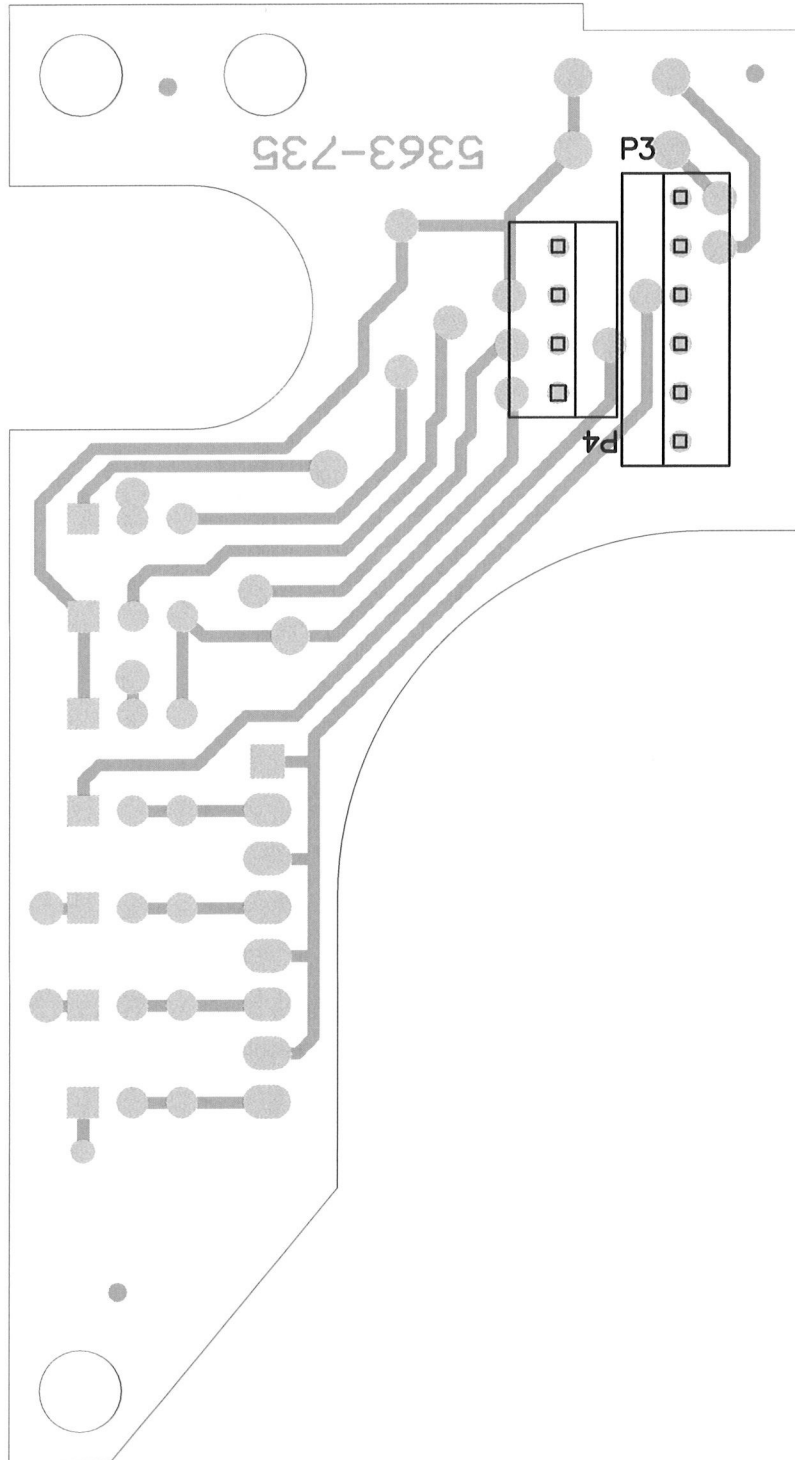



 <b>LUDLUM</b> MEASUREMENTS, INC.		PO Box 810 501 Oak Street Sweetwater, TX 79556 U.S.A. 1-800-622-0828	
<b>Title:</b> CALIBRATION BOARD			
<b>Drawn:</b> CKB	09/23/92	<b>Model:</b> 15	
<b>Design:</b> Initials	MM/DD/YY	<b>Board#:</b> 5363-735	
<b>Approve:</b> <i>RDS</i>	<i>24 Nov 14</i>	<b>Rev:</b> 2	
<i>PCBA Drawing</i>		<b>SCALE:</b> 1.05	<b>Series</b> Sheet
<b>Print Date:</b> 11/20/2014 1:13:12 PM		Bottom Overlay	363 586
<small>W:\Projects\LMIM 15\5363-735\Rev2\363735R2_Assy.PcbDoc</small>			

REVISIONS				DATE	APPROVED
EFF	AUTHORITY	ZONE	LTR	DESCRIPTION	

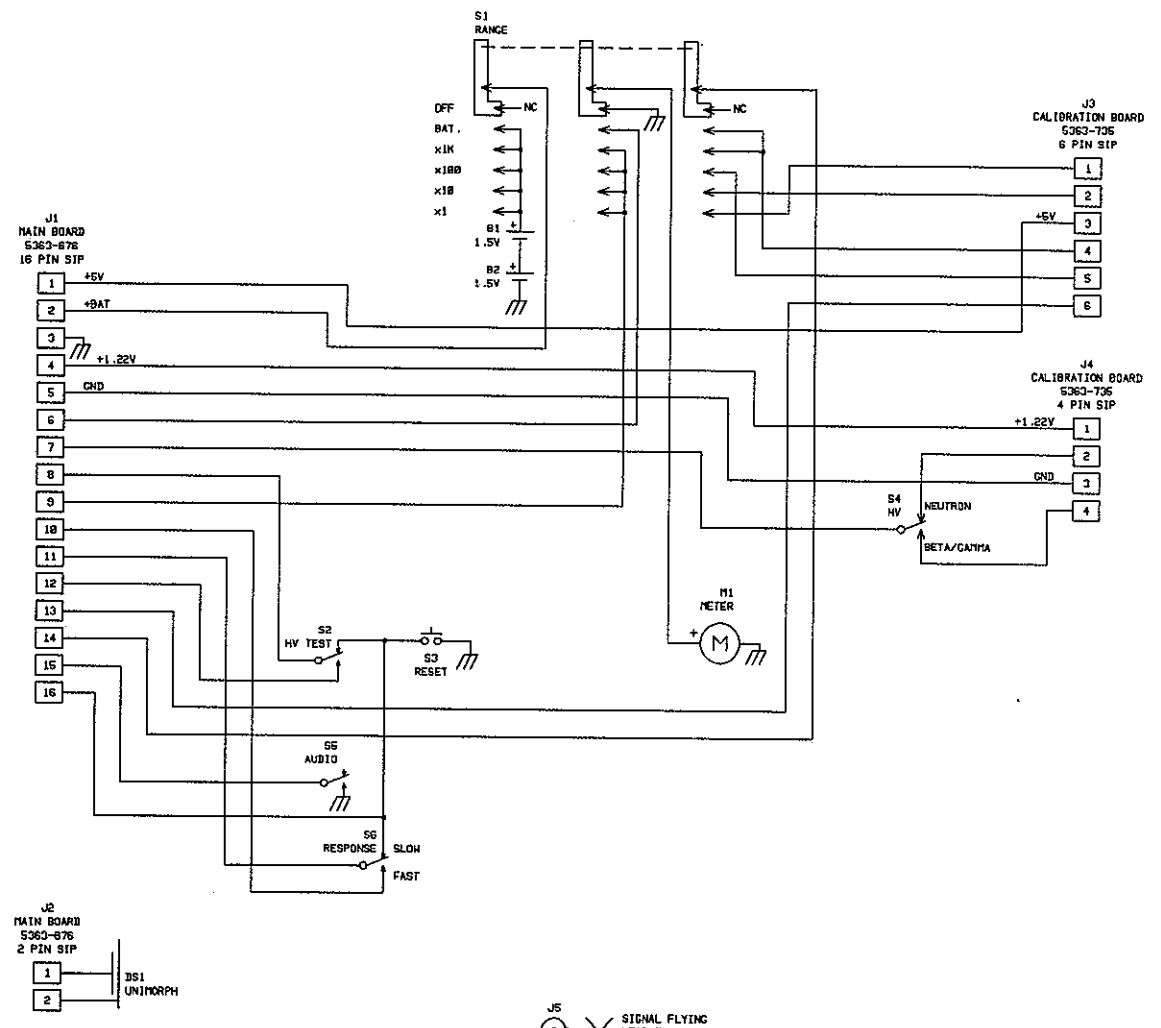

UPDATED	11/1	LUDLUM MEASUREMENTS INC.			
DR CKD	10/14/92	TITLE: WIRING DIAGRAM			
CHK	P.W. 11/6/92	BOARD# 363-735			
DSCN DL	07/90	SIZE	MODEL	SERIES	SHEET
APPD	JGW 11/6/92	D	1G	363	687
NEXT HIGHER ASSY.					
10:51:15	6-Nov-92	58363736			SHEET 1 OF 1

REV #	ALTERATIONS	DATE	BY
1	VALID	11/28/06	PW

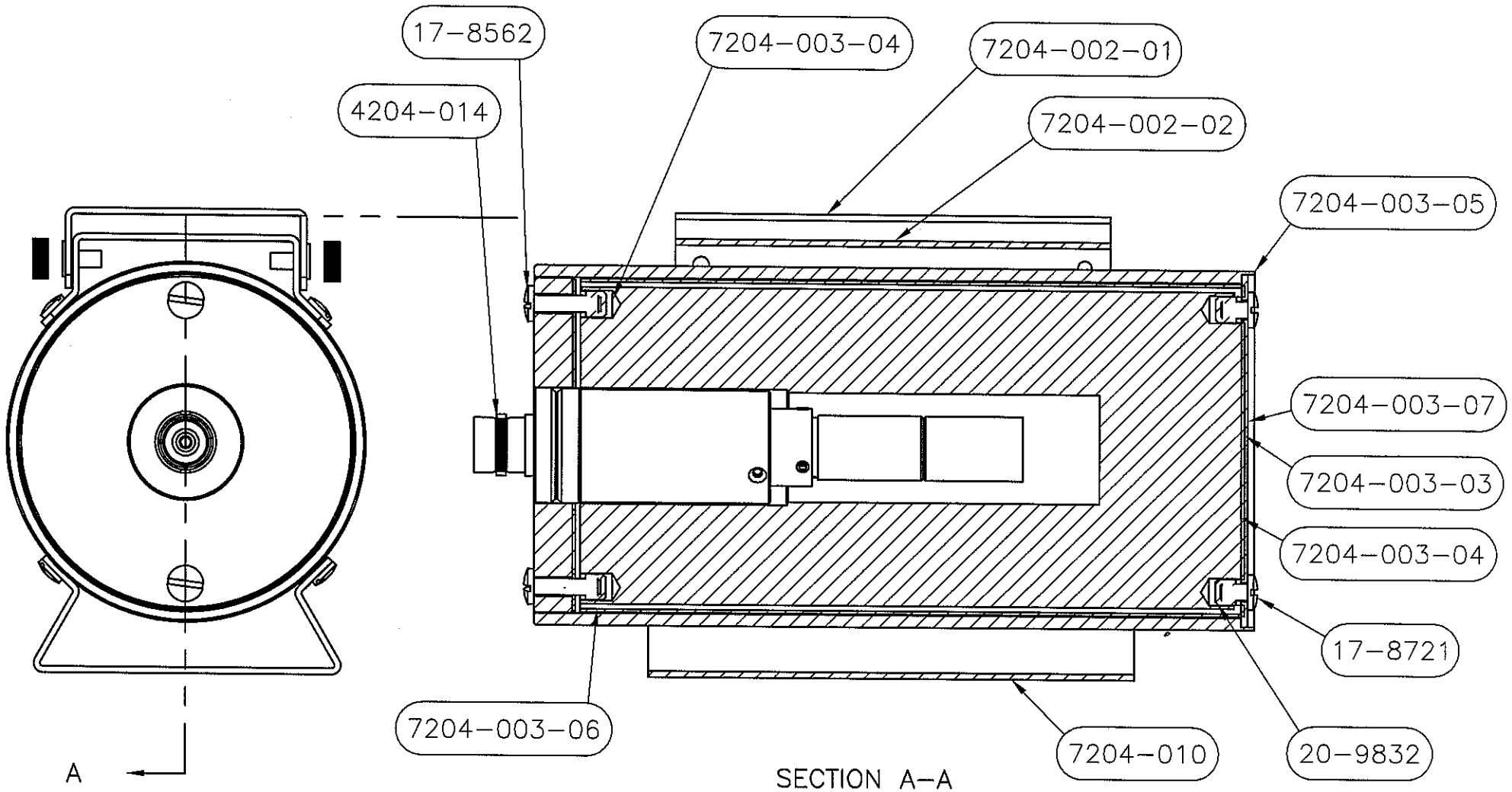

BVN	DATE	CHK	DATE	APP	DATE
PW	11/28/06			<i>[Signature]</i>	
PART NUM: 4204-016			SCALE: <input type="checkbox"/> FULL <input type="checkbox"/> OTHER		
TITLE M 42-14 HE <sup>3</sup> DETECTOR ASSEMBLY					
LUDLUM MEASUREMENTS, INC. 501 DWY STREET SWEETWATER, TEXAS 79556			SERIES	SHEET	
			204	16	

REVISION HISTORY			
REV	DESCRIPTION	DATE	BY
1	VALID	2-15-95	CLG
2	UPDATED	7/9/12	TMM

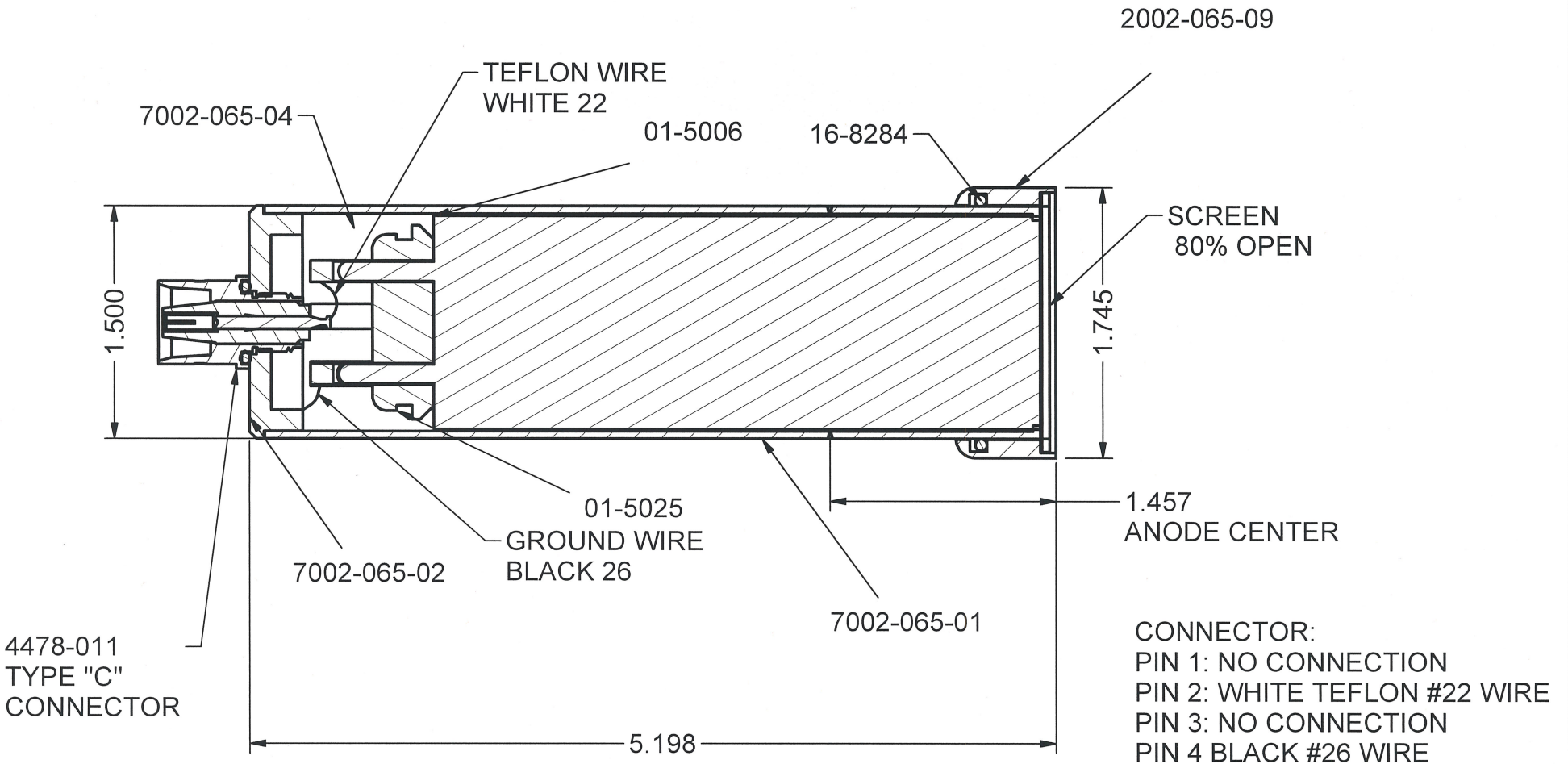

DWN	DATE	CHK	DATE	APP	DATE
TMM	7/10/12			<i>Plu</i>	7-10-2012
DWG NUM: 4002-212				SCALE: 1:1	
TITLE M 44-7 ASSEMBLY VIEW					
LUDLUM MEASUREMENTS, INC. 501 OAK STREET SWEETWATER, TEXAS 79556			SERIES	SHEET	
			2	157	