

**LUDLUM MODEL 3500-1000RWM
RADIATION WASTE MONITOR
ELECTRONICS MANUAL**

August 2006

**LUDLUM MODEL 3500-1000RWM
RADIATION WASTE MONITOR
ELECTRONICS MANUAL**

August 2006



LUDLUM MEASUREMENTS, INC.

501 OAK ST., P.O. BOX 810

SWEETWATER, TX 79556

325/235-5494 FAX: 325/235-4672

RECEIVING CONDITION EXAMINATION

Be sure to verify that the shipping carton is received in good condition with no visible damage. Should the instrument be received in a damaged condition, save the shipping container and the packing material and request an immediate inspection by the carrier.

RETURN OF GOODS TO MANUFACTURER

If equipment needs to be returned to Ludlum Measurements, Inc. for repair or calibration, please send to the address below. All shipments should include documentation containing return shipping address, customer name, telephone number, description of service requested, and all other necessary information. Your cooperation will expedite the return of your equipment.

**LUDLUM MEASUREMENTS, INC.
ATTN: REPAIR DEPARTMENT
501 OAK STREET
SWEETWATER, TX. 79556
800-622-0828(USA) 915-235-5494
FAX: 915-235-4672**

STATEMENT OF WARRANTY

Ludlum Measurements, Inc. warrants the products covered in this manual to be free of defects due to workmanship, material, and design for a period of twelve months from the date of delivery. The calibration of a product is warranted to be within its specified accuracy limits at the time of shipment. In the event of instrument failure, notify Ludlum Measurements to determine if repair, recalibration, or replacement is required.

This warranty excludes the replacement of photomultiplier tubes, G-M and proportional tubes, and scintillation crystals which are broken due to excessive physical abuse or used for purposes other than intended.

There are no warranties, express or implied, including without limitation any implied warranty of merchantability or fitness, which extend beyond the description of the face there of. If the product does not perform as warranted herein, purchaser's sole remedy shall be repair or replacement, at the option of Ludlum Measurements. In no event will Ludlum Measurements be liable for damages, lost revenue, lost wages, or any other incidental or consequential damages, arising from the purchase, use, or inability to use product.

RETURN OF GOODS TO MANUFACTURER

If equipment needs to be returned to Ludlum Measurements, Inc. for repair or calibration, please send to the address below. All shipments should include documentation containing return shipping address, customer name, telephone number, description of service requested, and all other necessary information. Your cooperation will expedite the return of your equipment.

**LUDLUM MEASUREMENTS, INC.
ATTN: REPAIR DEPARTMENT
501 OAK STREET
SWEETWATER, TX 79556**

**800-622-0828 325-235-5494
FAX 325-235-4672**

REV #	ALTERATIONS	DATE	BY
	VALID	12-23-98	JGW

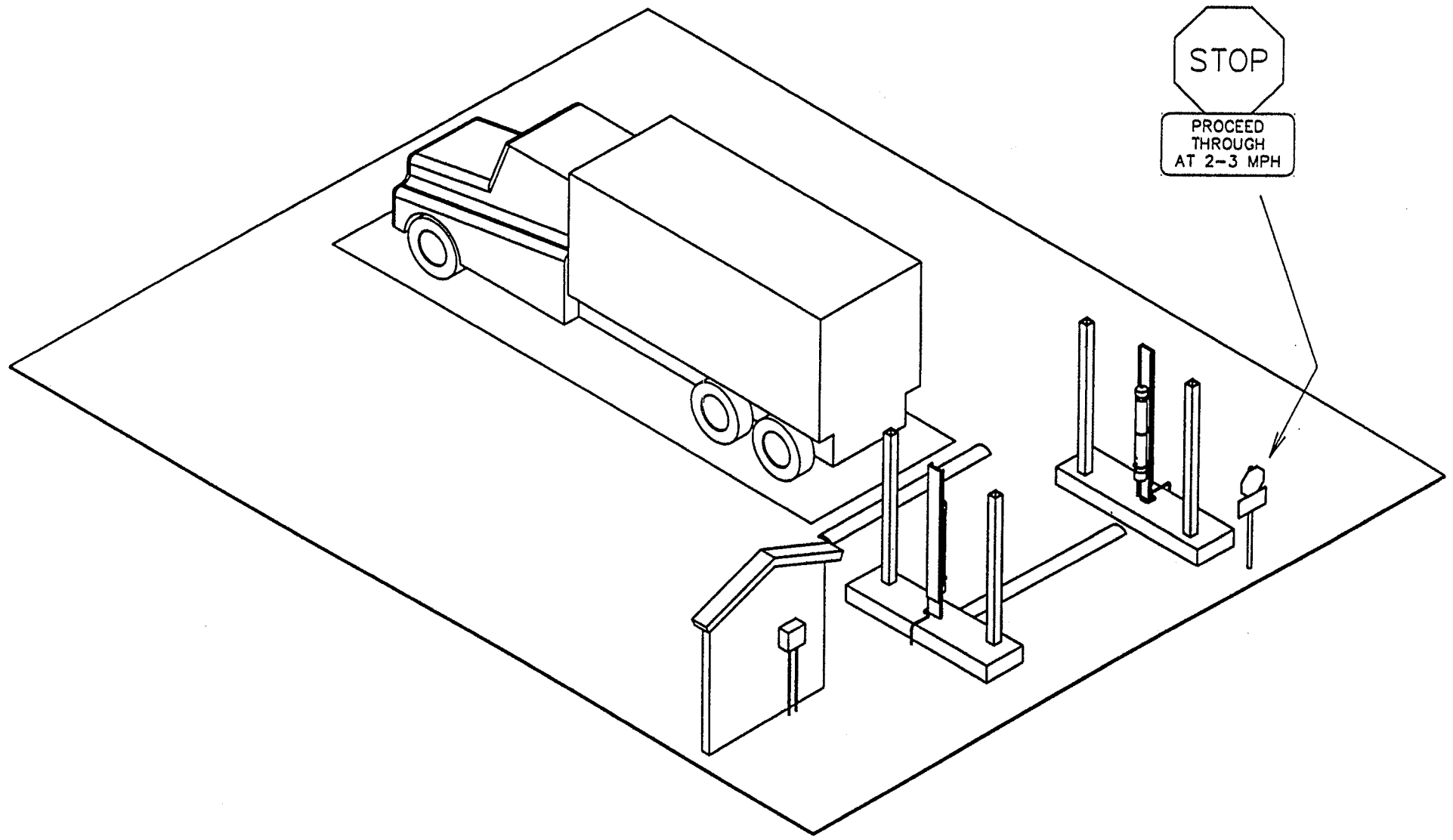

SHOWN WITH OPTIONAL CURB AND SPEED BUMPS

SEE ALSO SHEETS
384 X 336 A,B,C,D

OWN DATE	CHECKED	APPROVED
JGW 12-23-98	BSS 12-23-98	BLM 12-23-98
TITLE: M 3500-1K RWM ISO VIEW		
 LUDLUM MEASUREMENTS, INC. 301 OAK STREET EVICKVILLE, TEXAS 75726	SERIES 384	SHEET 336E

TABLE OF CONTENTS

1. GENERAL	4
2. HOW IT WORKS	4
3. PRELIMINARY INSTRUCTIONS	5
4. SPECIFICATIONS	6
5. INSTRUMENT CONTROLS AND FUNCTIONS	7
5.1 Front Panel	8
5.2 Connector Plate	8
6. OPERATING PROCEDURES	10
6.1 Initial Instrument Check	10
6.2 Alarm Check	10
6.3 Instrument Operation	11
7. TROUBLESHOOTING	12
8. PARTS LIST, COMPONENT LAYOUTS AND SCHEMATICS.....	13
Assembled System	13
Main Board Components, Layout and Schematic	14
LED Board Components, Layout and Schematic	15
Electronics Housing Components	16
System Wiring Diagram	17
Detectors	18
Appendix A: RADIATION: A Brief Explanation	19

MODEL 3500-1000RWM RADIATION WASTE MONITOR

1. GENERAL

The Model 3500-1000RWM Radiation Monitor System is designed to detect low levels of radiation in loads passing through the system.

Two scintillation detectors, each containing approximately 480 cubic inches of plastic detector media, provide coverage on both sides of a vehicle. The detectors' large size, 48 inches long by 5 inches wide by 2 inches thick, provides a large area for the capture of gamma radiation. The detectors are housed in weather-tight PVC pipes.

The microprocessor based electronics is constructed in a steel box. This unit provides automatic background compensation and automatic alarm point setting above the current background reading. Each detector has its

own high voltage power supply to minimize the risk of total system failure. The monitor is very easy to use and requires only minimal operator interaction. Upon power up, the monitor requires approximately fifteen seconds to measure background readings. It is then ready for operation. Diagnostic routines provide assurance that the system is operating correctly and indicators warn of possible detector failure. Meter override buttons check the count from each detector. Alarm settings are internal, allowing for tamper-resistant operation of the system. A digital RS-232 output is provided for connection of a computer or printer. An alarm relay output is also provided to drive additional beacons or sirens in an alarm condition.

2. HOW IT WORKS

The Model 3500-1000RWM Radiation Monitor is a two-channel dynamic monitoring system. It is designed primarily to be used at a facility's weigh scale or entry point; however, it can also be used in other areas as well.

The purpose of the system is to help in the detection of any sources of radiation in a load of material. It is strongly recommended that this be used as a first line of defense. This should be backed up by monitoring the material in the yard with a handheld unit periodically throughout the processing of the material to insure optimum coverage of the material.

When the system is turned on, it will perform a self-diagnostic routine and take background samples. Once the background is established, the alarm point will be automatically set at a certain point above the background reading.

NOTE: This alarm point is set at 6 deviations above background when shipped. It can be changed if desired by the operator.

After the first 15 seconds, the system will start to continuously monitor for an alarm. The system will also continuously update background so that the alarm point "tracks" above the background radiation level.

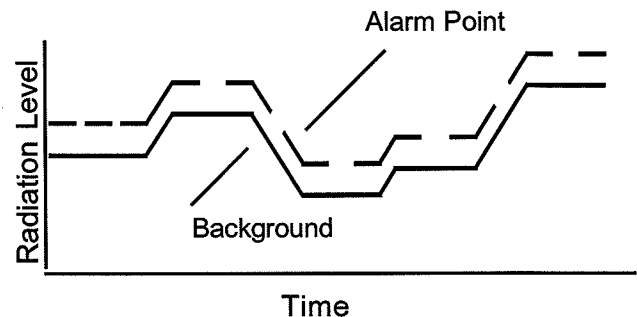

If the system detects excessive radiation, the alarm circuit will be activated to warn the user. Otherwise the system will resume background monitoring and is ready for the next vehicle.

2. HOW IT WORKS

In the event of an alarm, the user simply has to press the alarm reset button, and the instrument will then resume monitoring background. If the user wants to maintain the alarm condition until a supervisor or other person is aware of it, the user can press the AUDIO ACKNOWLEDGE button to silence the audio while still having the alarm identified by the lights.

Other options include a printer to obtain a hard copy of the data on the vehicle that caused the alarm or a computer interface to have all the data dumped to a file for use at a later time. This latter option also provides the user with a visual presentation of the approximate location of the source in the load on a depiction of the vehicle.

3. PRELIMINARY INSTRUCTIONS

UNPACKING AND REPACKING

Remove calibration certificate and place in secure location. Remove instrument and accessories (batteries, cable, etc.) and ensure that all of the items listed on the packing list are in the carton. If more than one instrument is in carton refer to the calibration certificate(s) for serial number match. The Model 3500-1000RWM S/N is located on the front panel near the lower left hand corner.

To return an instrument for repair or calibration provide sufficient packing material to prevent damage during shipment. Provide appropriate warning labels to ensure careful handling. Include detector(s) and related cable(s) for calibration. Include brief information as to the reason for return and return shipping instructions (address, P.O.#, etc.).

- return shipping address
- customer name or contact
- telephone number
- description of service requested
and all other necessary information

4. SPECIFICATIONS

ELECTRONICS

INDICATED USE: Low level radiation monitoring

SYSTEM OPERATION: The system continuously monitors radiation and compares the readings to the alarm level. If the alarm threshold is breached, the audible and visual alarms are activated.

DETECTORS: 2 ea. 480 cubic-inch plastic detectors in weather tight PVC enclosures

AUDIO: Unimorph type speaker with volume control (*greater than 80 dB at 2 feet*)

METER: 6" (15.2cm) arc 1 mA analog type

METER DIAL: 0 - 25 kcps

POWER OK: (*green LED*) Indicates that the power is connected to the system

SYSTEM OK: (*green LED*) Indicates that system is functioning properly

CHECKING: (*green LED*) Indicates radiation levels are being monitored

CHANNEL 1: Pushbutton to check current radiation level of channel 1

CHANNEL 2: Pushbutton to check current radiation level of channel 2

ALARM: Indicated by red LED's, and audible tone (*can be set internally from 4 - 34 deviations above background in 2-deviation increments*)

FAIL: (*yellow LED's*) Indicates when signal not received from the detectors and/or high background

RS-232: 9 pin connector to allow for connection of computer or printer

CONTROLS: (unused option)

RELAYS: 3 pin connector allowing for connection of external alarm indicators

SETUP CONTROLS:(internal)

DETECTOR NUMBER(DET): A two-position dip switch to select between using one detector or two detectors.

PC / PRINTER: A two position dip switch that is used to select a printer output or PC output for the RS-232 port.

ALARM LEVEL: A 16-position rotating switch. labeled from 0-9, A-F. Zero indicates an alarm point of 4 sigma. Each increment increases the alarm point by 2 sigma, up to a maximum of 34 sigma at setting "F."

POWER: 95 - 135 VAC (*178 - 240 VAC available on request*), 50-60 Hz single phase (*less than 100 mA*)

CONSTRUCTION: Steel NEMA 12 enclosure

TEMPERATURE RANGE: -20°F(-29°C) to 140°F(60°C)

May be certified to operate from -40°F(-40°C) to 150°F(65°C)

SIZE: 12.3"(31.8cm)H X 15"(38.1cm)W X 6.8"(17.1cm)D

WEIGHT: 18 lbs (8.2kg)

DETECTORS

SCINTILLATOR: 480 in³ plastic detector media (each)

TUBE: 1.125" (2.9 cm) diameter magnetically shielded photomultiplier

HOUSING: 6" diameter PVC

SIZE: approximately 7" diameter X 64" long

WEIGHT: 70 lbs (31.8 kg) each

MODEL 3500-1000RWM RADIATION WASTE MONITOR

5. INSTRUMENT CONTROLS AND FUNCTIONS

5.1 Front Panel

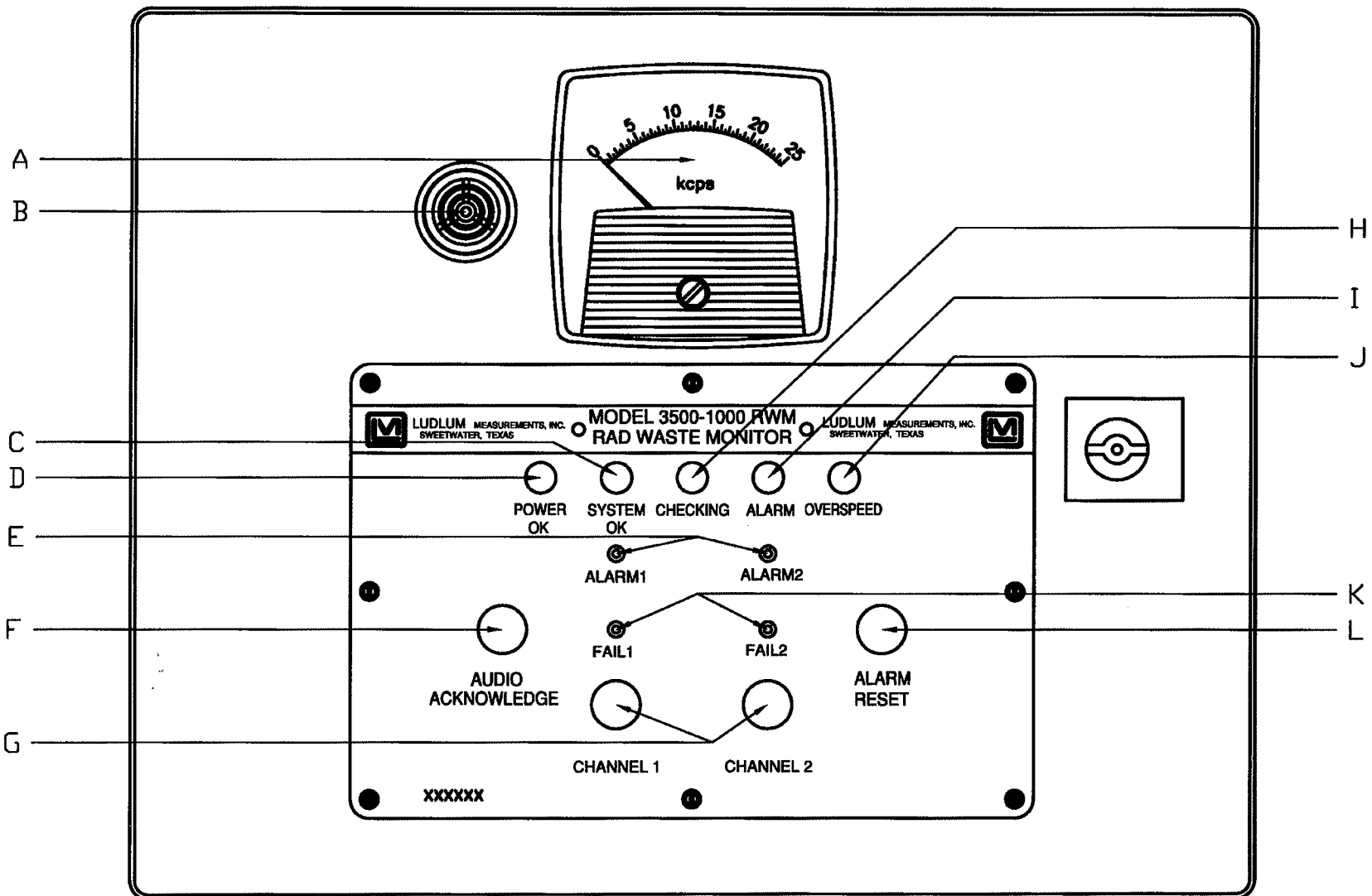

5. INSTRUMENT CONTROLS AND FUNCTIONS

- A. METER:** Provides a visual reading of the radiation level being monitored with a range from 0 - 25 kcps.
- B. AUDIO UNIMORPH:** Provides an audible tone in the event of an alarm (*greater than 80 dB at 2 feet(0.61m)*).
- C. SYSTEM OK LED:** A green LED which lets the user know that the system is operating properly.
- D. POWER OK LED:** A green LED that indicates that the instrument is connected to a power source and is turned on.
- E. CHANNEL ALARM INDICATORS:** A set of red LED's labeled ALARM1, and ALARM2 to let the user know which detector caused an alarm.
- F. AUDIO ACKNOWLEDGE:** A pushbutton to silence the audio after an alarm has been indicated.
- G. METER OVERRIDE BUTTONS:** Two pushbuttons labeled CHANNEL 1 and CHANNEL 2 that allow the operator to view the reading coming from each channel on the meter.
- H. CHECKING:** A green LED that lets the user know that the system is "monitoring."
- I. ALARM:** A red LED that lets the user know when an alarm has been indicated.
- J. OVERSPEED (optional-not used on this model):** A red LED that lets the user know when a vehicle has passed through the system at a speed greater than 6 mph(9.66kmph).
- K. FAILURE INDICATORS:** Two yellow LED's labeled FAIL1 and FAIL2 that let the user know if the system has had a detector failure.
- L. ALARM RESET:** A pushbutton that is used to reset both the audible and visual alarm indicators after an alarm has been indicated.

5. INSTRUMENT CONTROLS AND FUNCTIONS

5.2 Connector Plate

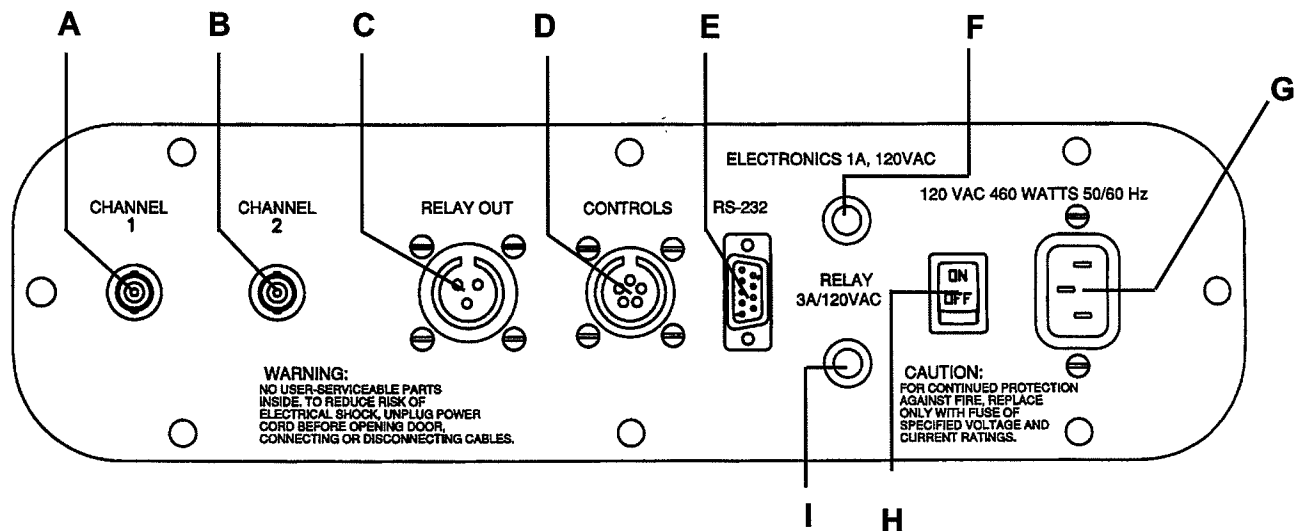

- A. **CHANNEL 1:** A BNC connector to allow for connection of one detector to the electronics.
- B. **CHANNEL 2:** A BNC connector to allow for connection of a second detector to the electronics.
- C. **RELAY OUT:** A three-pin connector which allows for connection of an optional alarm strobe or horn.
- D. **CONTROLS (not used for this model):** A five-pin connector which allows the optional vehicle sensor to be connected to the electronics.
- E. **RS-232:** A nine-pin connector to allow for connection of a printer or computer to the system.
- F. **ELECTRONICS 1A:** A 1 amp fuse to protect the electronics from a power surge or internal component failure.
- G. **120 VAC:** A three-pin connector for the instrument power cord.
- H. **ON/OFF:** A two-position rocker switch to turn the power on or off
- I. **RELAY 3A:** A three-amp fuse to protect the optional strobe or horn in the event of a power surge or internal component failure.

6. OPERATING PROCEDURES

6.1 Initial Instrument Check

Once the Model 3500-1000RWM Gate Monitor has been properly installed it should be ready for normal operation. The following procedures will take you through the initial checkout of the instrument and its operation.

NOTE: Installation instructions, with drawings and diagrams, can be found in a separate manual: "Model 3500-1000RWM Installation Manual."

1. Ensure that detectors and any optional accessories are properly connected to the main electronics (*i.e., printer, computer, strobes, horns, etc.*).
2. Confirm that the main electronics is connected to 110 VAC (220 VAC *if applicable*).

3. Flip the power switch on the connector plate to the ON position.

NOTE: When this is done, the meter should momentarily deflect to full scale, and all of the lights on the electronics will light up for approximately one second. The meter will then begin indicating a reading from the detectors. The lights should all go off with the exception of the POWER OK light which will stay on and the SYSTEM OK light which will flash for approximately fifteen seconds while the instrument obtains a background reading and completes a diagnostic check of all parameters. The SYSTEM OK light will then come on and stay on.

6.2 Alarm Check

For the next part of the checkout it is necessary to use the check source that is provided with the instrument to check the alarm function for proper operation.

1. You should get the source and place it so that it is located on the Ludlum Measurements, Inc. sticker on the detector.

NOTE: The alarm circuit should activate causing the audio to come on and the alarm lamp to light up. The ALARM1 or ALARM2 lamp should also illuminate, depending on which detector is being tested. Any remote alarm indicators should also be activated (*i.e. strobe or horn if applicable*).

2. Press the AUDIO ACKNOWLEDGE button. The audio on the electronics should quit, but the alarm lights and remote indicators will still be activated.
3. Press the ALARM RESET button. All alarm indicators should go off, including any remote strobe or horn that is connected (*if applicable*).

Repeat this procedure for the other detector. Once completed successfully, the system is ready for normal operation.

Note: This procedure should be performed periodically. It is suggested that it be done on a daily basis. As long as the instrument passes the alarm check, there is no need for a complete recalibration.

6. OPERATING PROCEDURES

6.2 Alarm Check (continued)

4. The alarm point is user-adjustable by way of the 16-position rotary switch located on the main board. This switch is located mid-point along the bottom edge of the main board and is marked "ALARM." The factory setting is 6 deviations above background, which is position "1" on the switch. This is equivalent to approximately 1.1 $\mu\text{R/hr}$ above the normal background exposure rate of 8 $\mu\text{R/hr}$. It should be noted, however, that the background rate is reduced to 4 $\mu\text{R/hr}$ at the detectors, due to the detectors' shielding. Examples of alarm settings are calculated as follows (assuming ambient background of 8 $\mu\text{R/hr}$ or 4 $\mu\text{R/hr}$ at the detectors):

<u>Switch Position</u>	<u>Number of Deviations</u>	<u>Approximate Amount Above Background at Detectors ($\mu\text{R/hr}$)</u>
0	4	0.4
1	6	0.7
2	8	0.9
3	10	1.1
4	12	1.3
5	14	1.5
6	16	1.7
7	18	2.0
8	20	2.2
9	22	2.4
A	24	2.6
B	26	2.8
C	28	3.1
D	30	3.3
E	32	3.5
F	34	3.7

6.3 Instrument Operation

During normal operation there is very little operator intervention required. After the procedures in 6.1 and 6.2 have been completed, the system is ready to monitor.

In the event of an alarm, the system is easily reset by pressing the ALARM RESET button on the front panel. Once this is done, the instrument is again ready to monitor.

7. TROUBLESHOOTING

This section is intended to assist the user of the Model 3500-1000RWM Gate Monitor system in isolating and identifying problems with the system if and when they occur. Ludlum Measurements, Inc. (LMI) provides technical support for our customers

who wish to repair their instruments. If you have any questions regarding instrument repairs, please contact our repair/calibration department at 1-800-622-0828 (USA and Canada) or 915-235-5494. Our fax number is 915-235-4672, and our email address is ludlum@camalott.com.

<u>SYMPTOM</u>	<u>PROBABLE CAUSE</u>	<u>POTENTIAL SOLUTION</u>
Detector fail light comes on.	The system electronics is either receiving an excessively high number of counts or no counts from the detector.	<p>Check the detector and cabling to insure proper connection.</p> <p>"Excessive counts" usually indicates a bad cable connection or broken detector.</p> <p>"No counts" usually indicates a disconnected detector.</p>

<u>SYMPTOM</u>	<u>PROBABLE CAUSE</u>	<u>POTENTIAL SOLUTION</u>
One detector continually alarms.	The electronics are not working properly.	Switch detector connections at the electronics and see if the problem follows the detector or stays on the same channel. If the problem follows the detector, then the problem is not in the electronics.
	The cable has failed and is causing excessive noise.	Swap a "good" detector for a "bad" one. If the problem persists, the cable should be replaced.
	The detector is not working	The detector must be repaired.

If the above recommendations do not correct the problem, the problem is most likely more serious in nature and will probably need to be investigated by an electronics technician.

MODEL 3500-1000RWM RADIATION WASTE MONITOR

8. PARTS LIST, COMPONENT LAYOUTS, AND SCHEMATICS

Model 3500-1000RWM Gate Monitor System

Ref No.	Description	Part Number
UNIT	Completely Assembled Model 3500-1000RWM Gate Monitor System	48-3078

8. PARTS LIST, COMPONENT LAYOUTS, AND SCHEMATICS

Model 3500-1000RWM Gate Monitor System

Main Board Components

Ref No.	Description	Part Number
Board	Assembled Main Board	5384-884

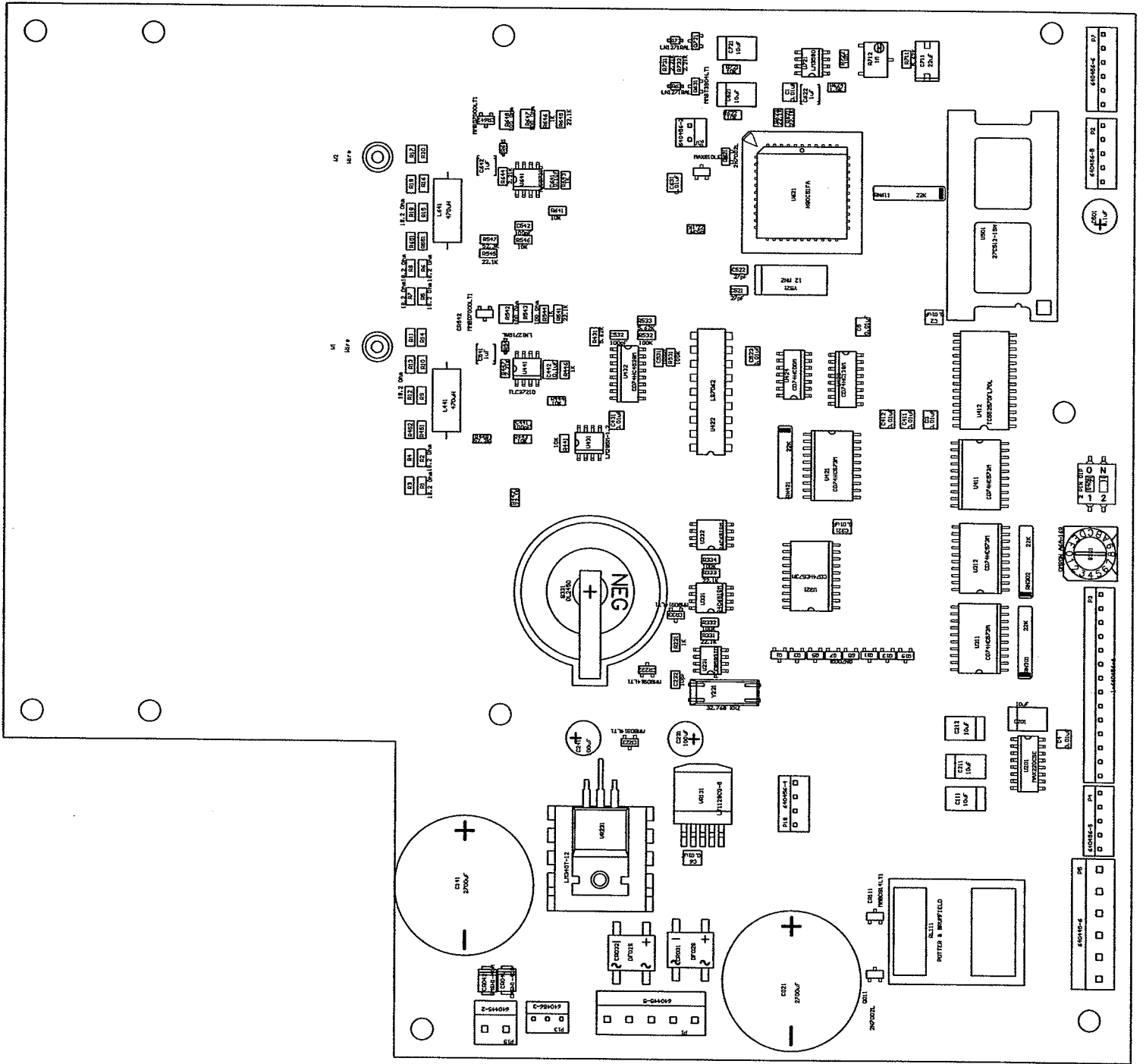

Drawn: SA	03/25/05	Title:	
Design: RSS	03/25/05	MAIN BOARD	
		Model: 3523-1	
Approve: <i>RS</i>	<i>22 Aug 06</i>	Board#: 5384-884	
Layer: Mech.1	MD:	Rev: 2.0	Series
11:47:41	22-Aug-2006	SCALE: 0.94	Sheet
BS384884.PCB		384	885

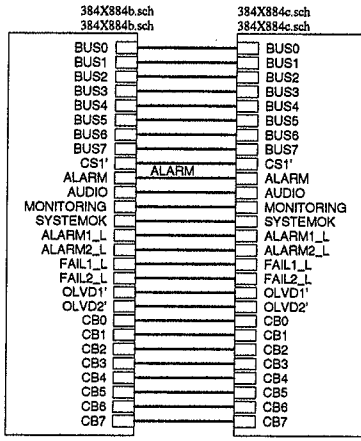
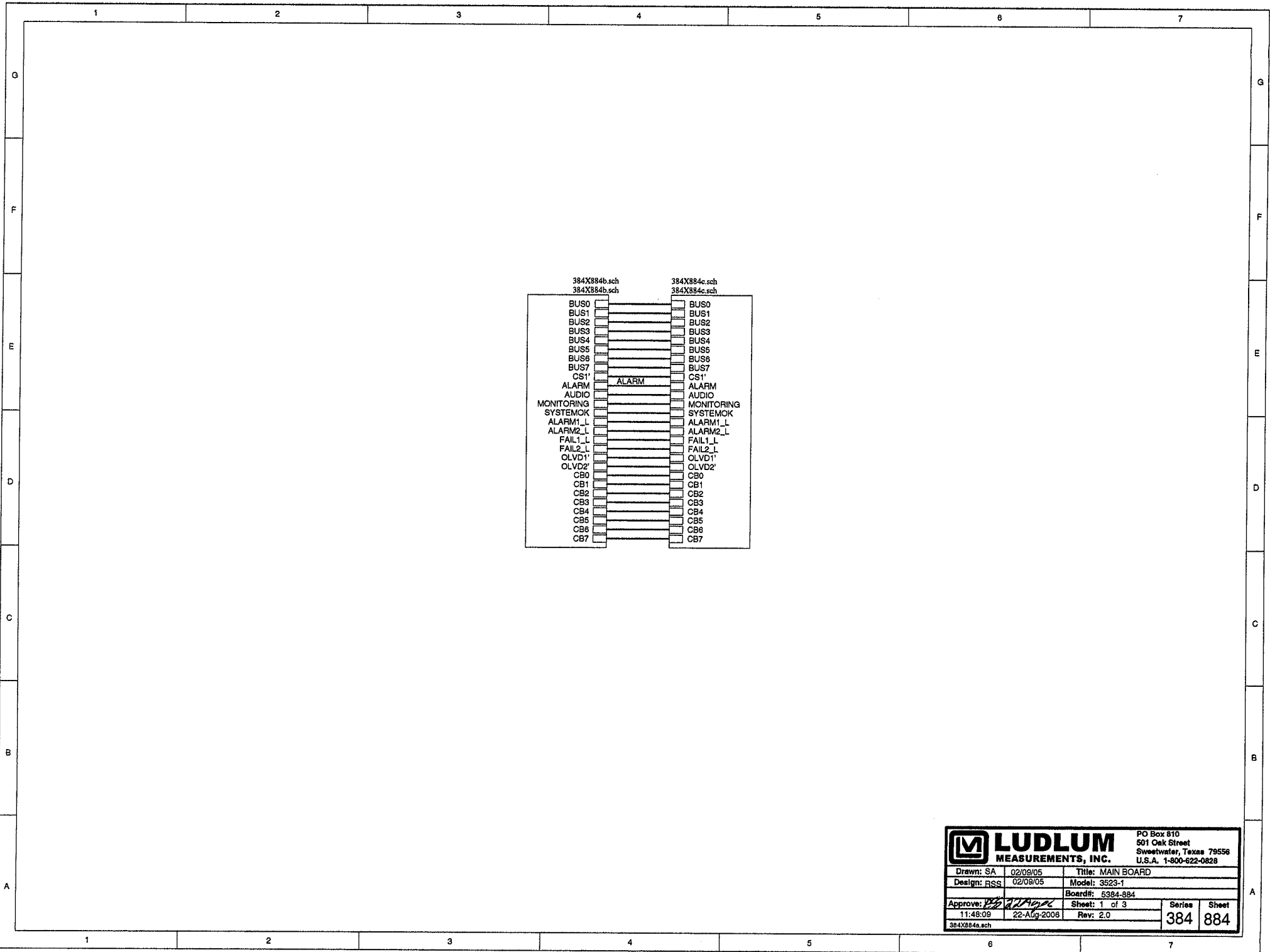

		PO Box 810 501 Oak Street Sweetwater, Texas 79556 U.S.A. 1-800-622-0828	
Drawn: SA	02/09/05	Title: MAIN BOARD	
Design: RSS	02/09/05	Model: 3523-1	
		Board#: 6384-884	
Approve: <i>[Signature]</i>		Sheet: 1 of 3	Series
11:48:09	22-Aug-2008	Rev: 2.0	Sheet
384X884a.sch		384	884

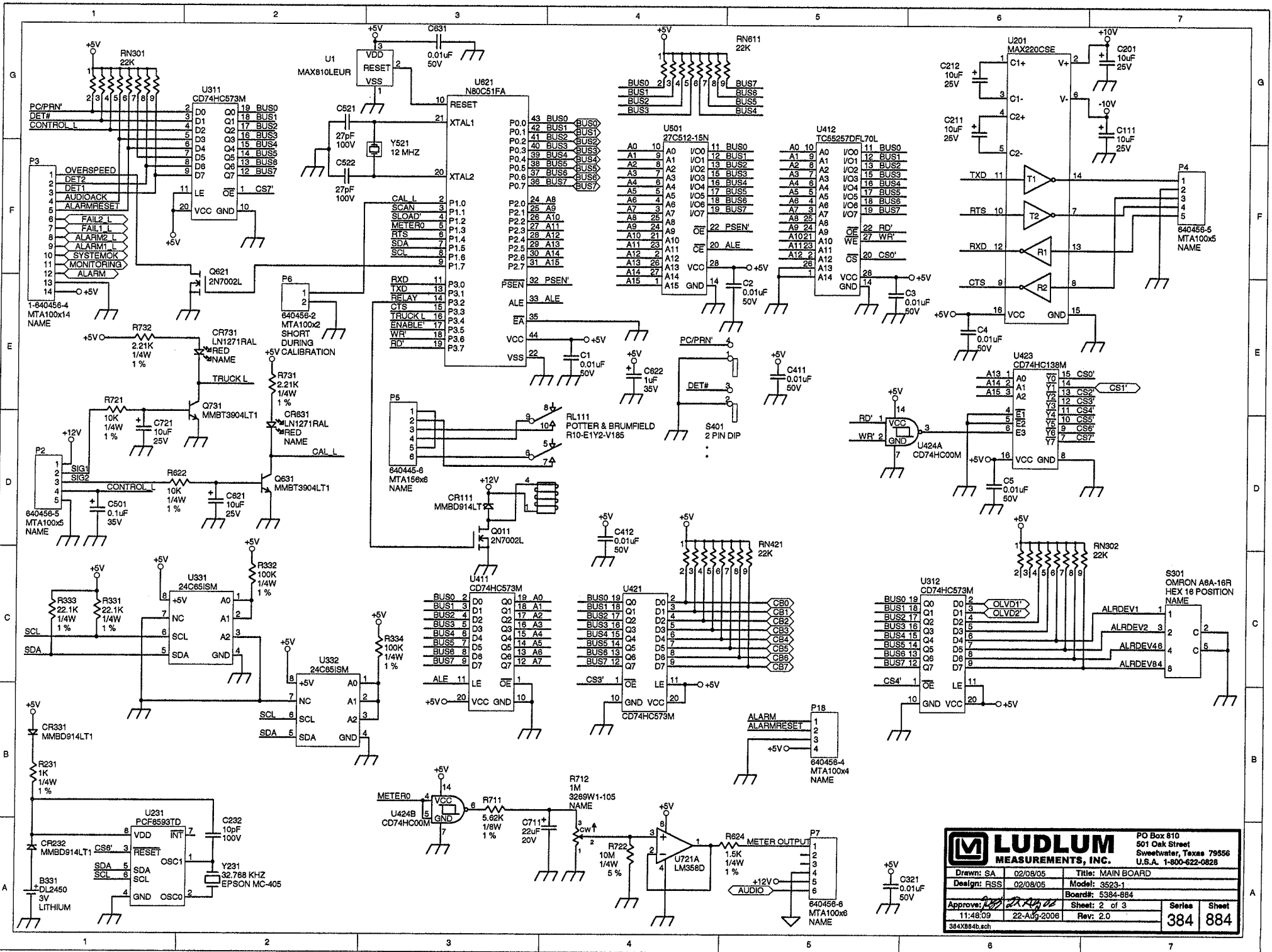

LUDLUM MEASUREMENTS, INC.
 PO Box 610
 501 Oak Street
 Sweetwater, Texas 79556
 U.S.A. 1-800-622-0828

Drawn: SA	02/08/05	Title: MAIN BOARD
Design: RSS	02/08/05	Model: 3523-1
Board: 5384-884		
Approved: [Signature]	22-AUG-2006	Sheet: 2 of 3
11:48:09	Rev: 2.0	Series
384	884	Sheet

384X884b.sch

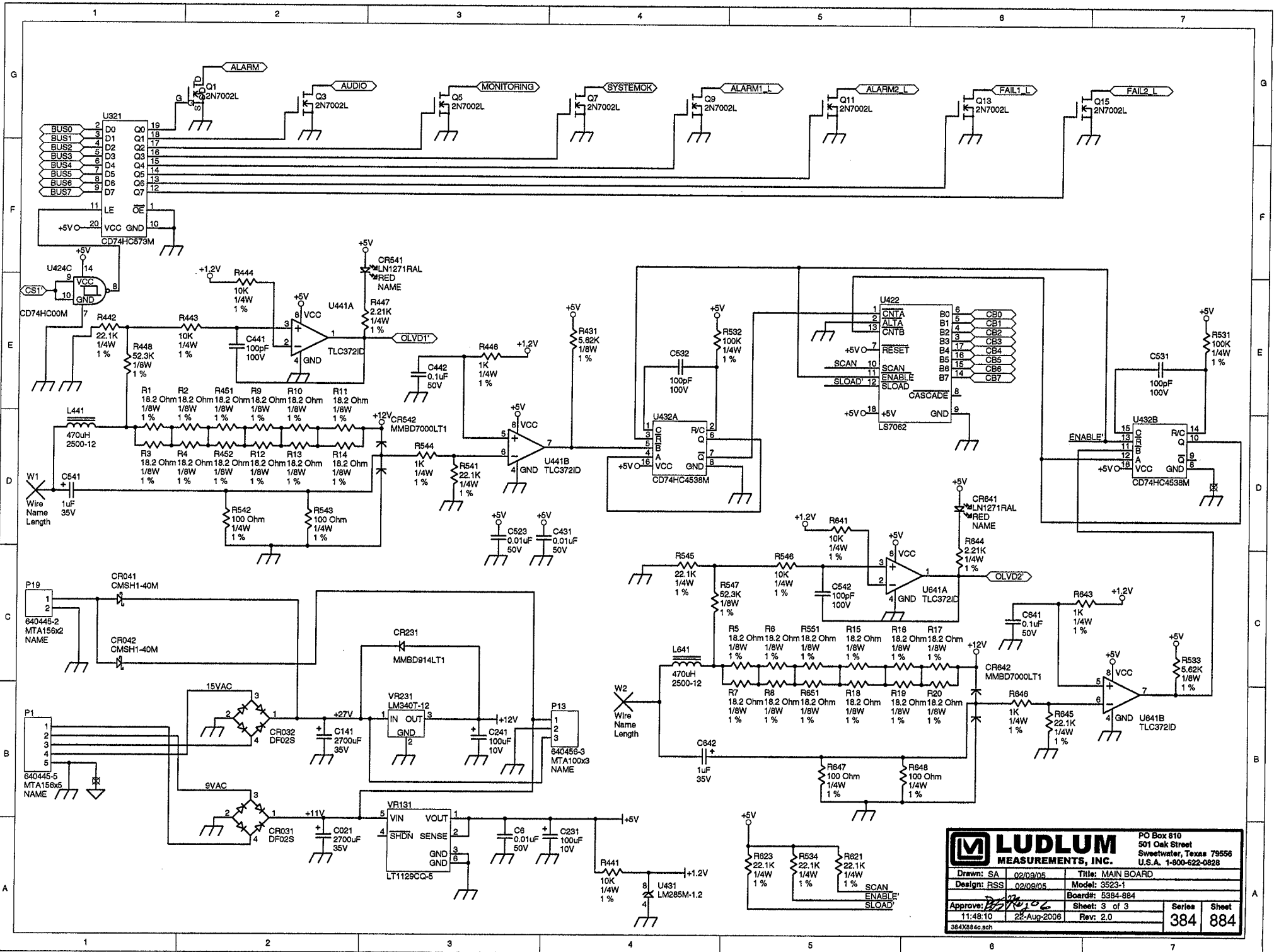

LUDLUM MEASUREMENTS, INC.
 PO Box 610
 501 Oak Street
 Sweetwater, Texas 79556
 U.S.A. 1-800-622-0828

Drawn: SA	02/08/05	Title: MAIN BOARD
Design: RSS	02/08/05	Model: 3523-1
Board#: 5394-884		
Sheet: 3 of 3		
Series	Sheet	
11:48:10	28-Aug-2006	Rev: 2.0
384X884c sch	384	884

8. PARTS LIST, COMPONENT LAYOUTS, AND SCHEMATICS

Model 3500-1000RWM Gate Monitor System

LED Board Components

Ref No.	Description	Part Number
Board	Assembled LED Board	5384-187

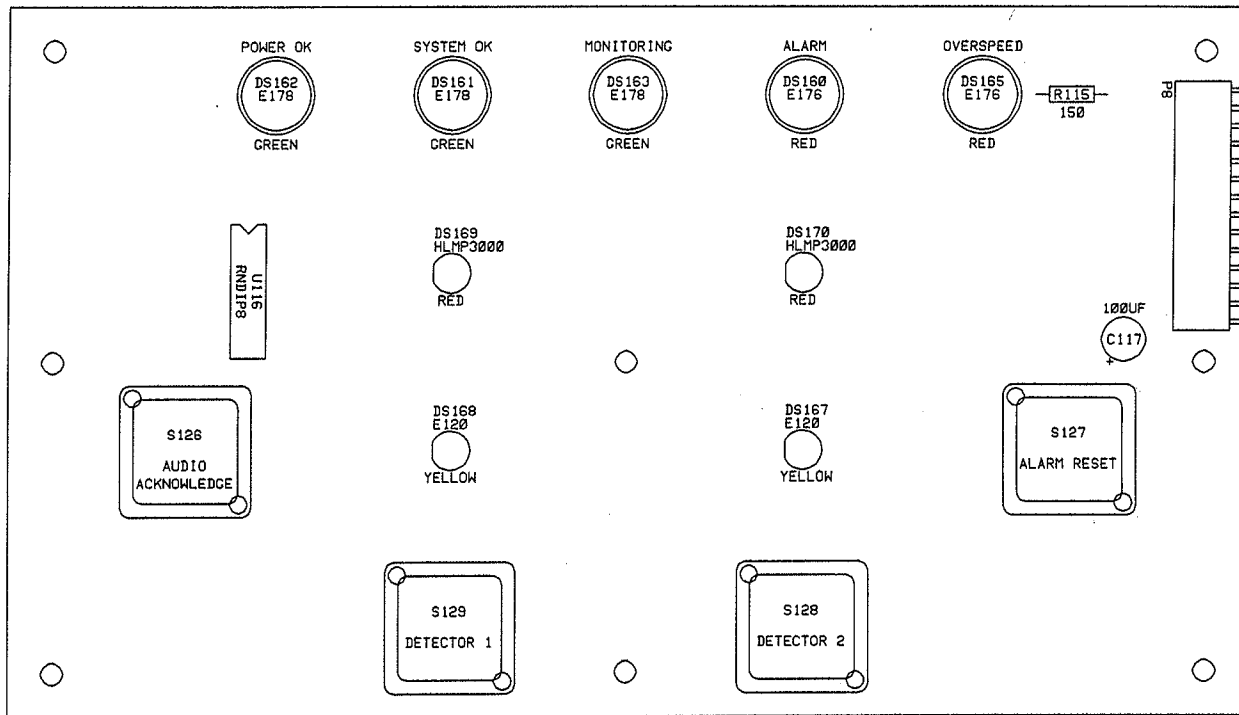

<input checked="" type="checkbox"/> LUDLUM MEASUREMENTS INC. SHEETWATER, TX.			
DR	RSS	07-24-95	TITLE: LED BOARD
CHK	P.W.	6-17-98	BOARD# 5384-187 89384187
DSGN	RSS	07-24-95	MODEL 3523 SERIES 384 SHEET 136
APP	RSS	6-Jun-98	COMP ARTWORK <input type="checkbox"/> SLDR ARTWORK <input type="checkbox"/>
Ø8:35:57			COMP OUTLINE <input type="checkbox"/> SLDR OUTLINE <input type="checkbox"/>
			COMP PASTE <input type="checkbox"/> COMP MASK <input type="checkbox"/> SLDR PASTE <input type="checkbox"/> SLDR MASK <input type="checkbox"/>

REVISIONS				DATE	APPROVED
EFF	AUTHORITY	ZONE	LTR	DESCRIPTION	

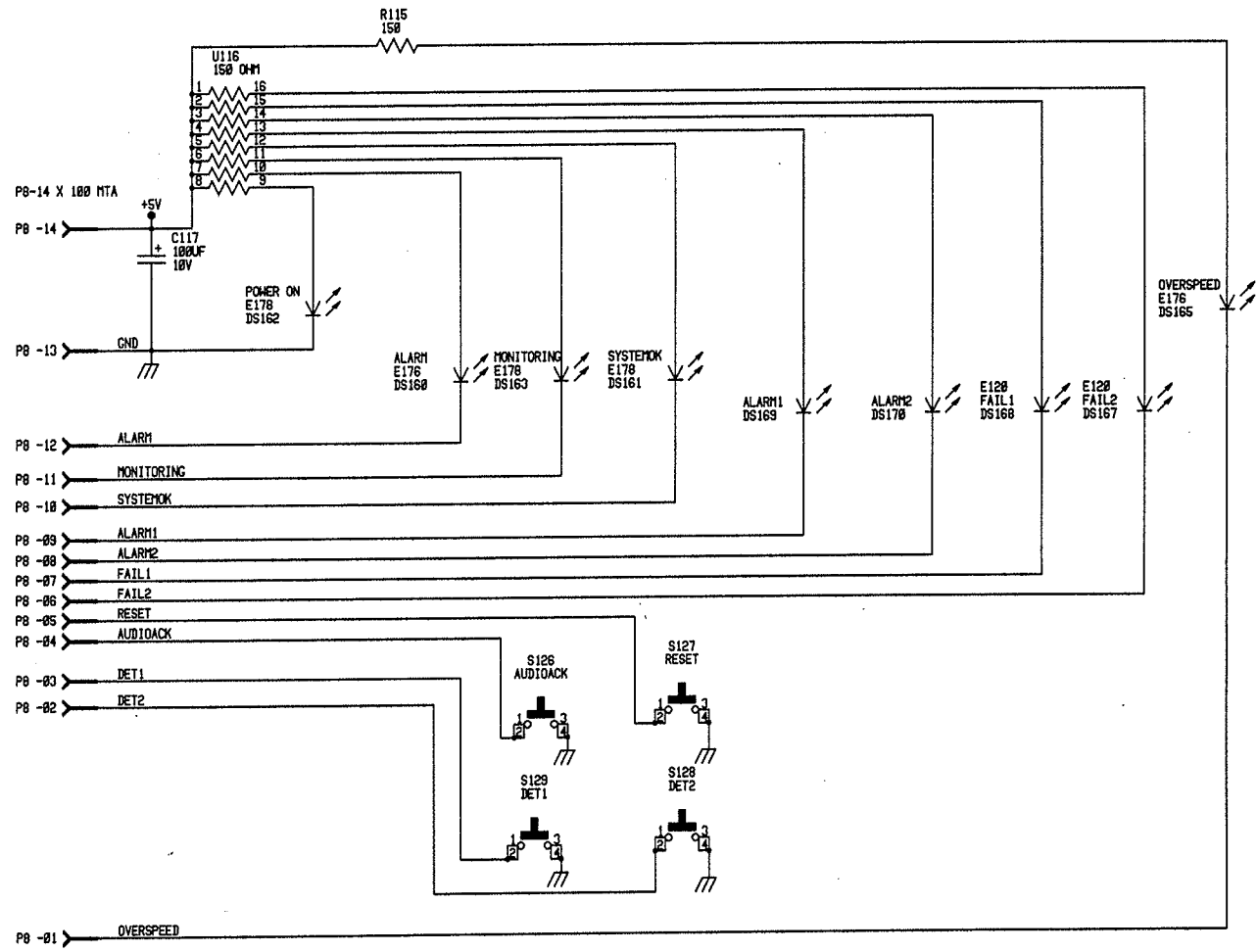

UPDATED	-	LUDLUM MEASUREMENTS INC.			
DR	RSS	07-24-95	TITLE: LED BOARD		
CHK	P.W.	6.14.95	BOARD# 5384-187		
DSGN	RSS	07-24-95	SIZE	MODEL	SHEET
APPD	RDS	12 Jun 98	C	3523	384
NEXT HIGHER ASSY.					135
BB:58:42		17-Jun-98	SB384187		SHEET 1 OF 1

MODEL 3500-1000RWM RADIATION WASTE MONITOR

8. PARTS LIST, COMPONENT LAYOUTS, AND SCHEMATICS

Model 3500-1000RWM Gate Monitor System

Electronics Housing Components

Ref No.	Description	Part Number
Connector Plate	Assembled Plate	4384-263

REV #	ALTERATIONS	DATE	BY
	VALID	06-30-98	TJR

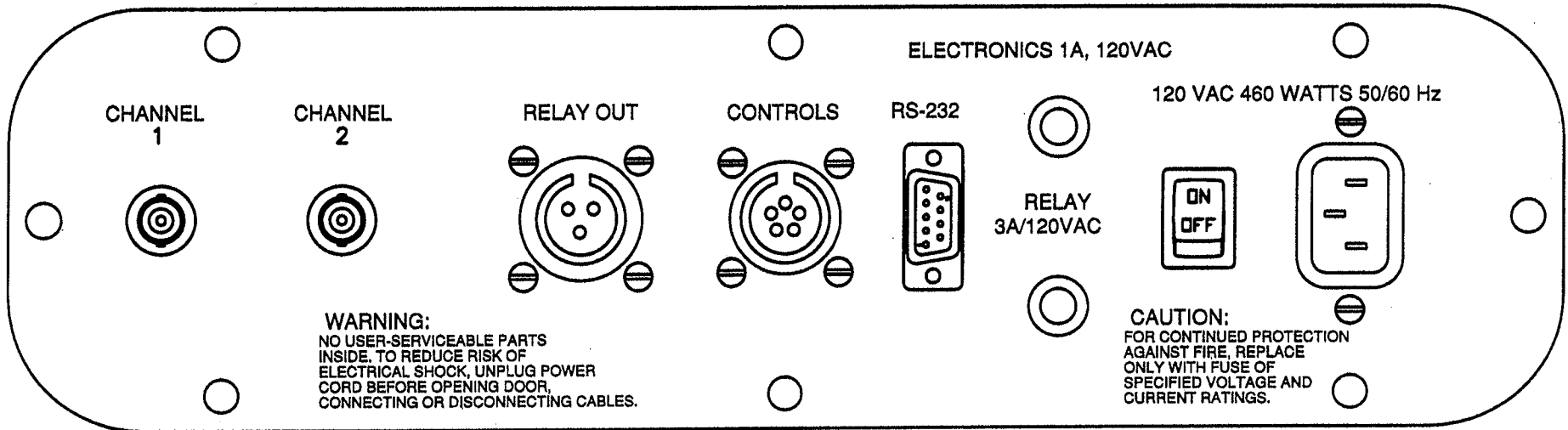

DESIGNED BY TJR	DATE 06-30-98	CHECKED	APPROVED Jaw 6-30-98
TITLE: M 3500-1000 CON. PLATE			
LUDLUM MANUFACTURING, INC. 90 ONE STREET BARTONVILLE, ILLINOIS 60010		SERIES 384	SHEET 324

8. PARTS LIST, COMPONENT LAYOUTS, AND SCHEMATICS

Model 3500-1000RWM Gate Monitor System

Wiring Diagram

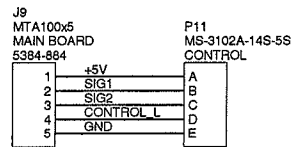
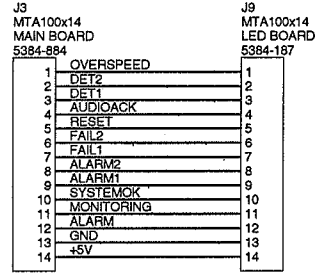
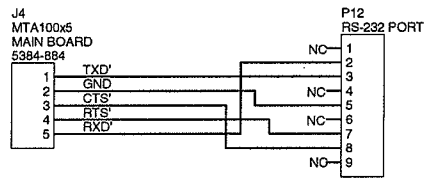
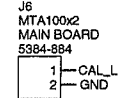
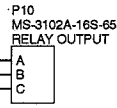
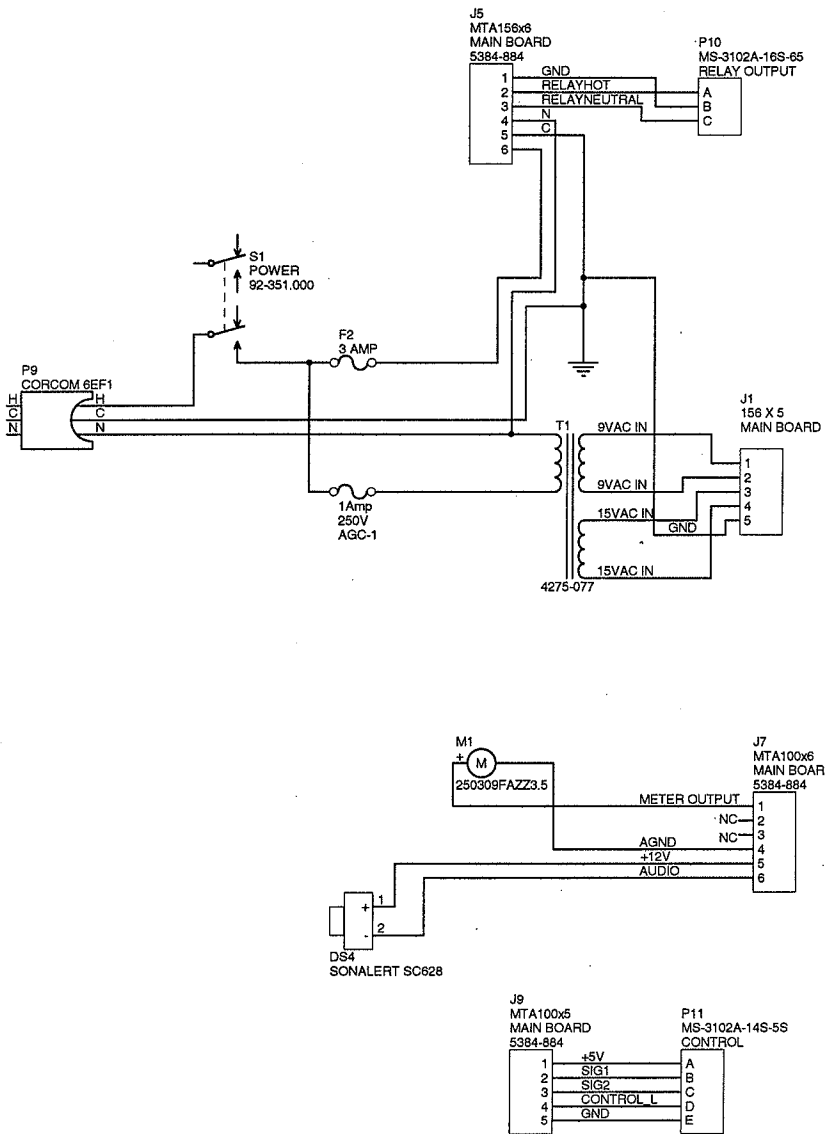

		PO Box 810	
		501 Oak Street Sweetwater, Texas 79556 U.S.A. 1-800-622-0828	
Drawn: SA	08/27/06	Title: WIRING DIAGRAM	
Design: RSS	08/27/06	Model: 3500-1000 -3000 -6000 -7500	
Check:		Board#: 384-486	
Approved: <i>[Signature]</i>	10:24:45	28-Aug-2006	Rev: 2.0
Sheet: 1 of 1		Series: 384	Sheet: 486

MODEL 3500-1000RWM RADIATION WASTE MONITOR

8. PARTS LIST, COMPONENT LAYOUTS, AND SCHEMATICS

Model 3500-1000RWM Gate Monitor System

Detectors

Ref No.	Description	Part Number
2 ea.	Model 44-128 Detector	47-2957
Board	Assembled Detector Interface	5344-135
Board	Assembled Voltage Divider	5002-241

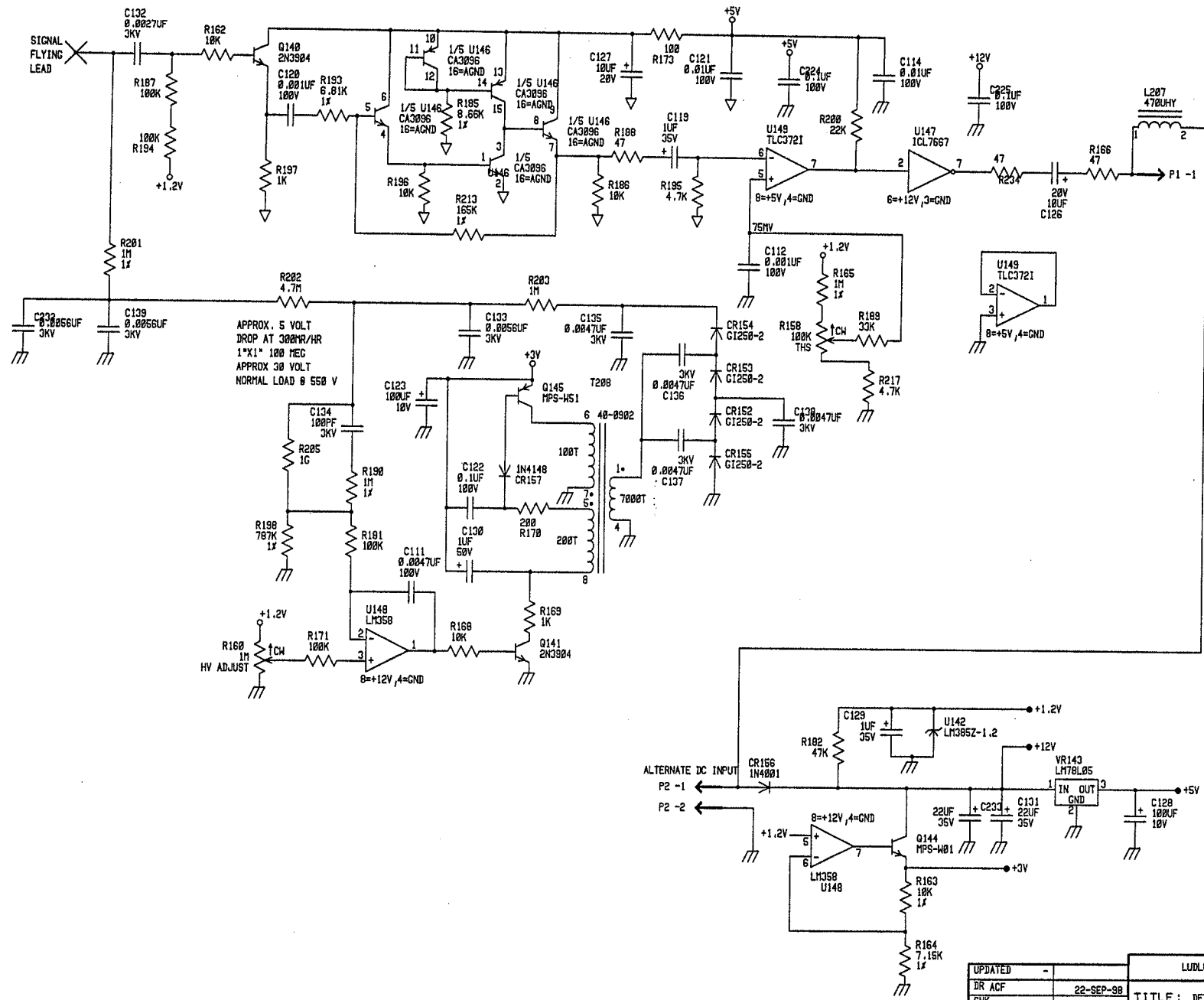

UPDATED	-	LUDLUM MEASUREMENTS INC.		
DR ACF	22-SEP-98	TITLE: DETECTOR INTERFACE BOARD		
CHK		BOARD# 5344-135		
DSGN RSS	14-SEP-98	SIZE	MODEL	SERIES
APPD		C	440-7	344
NEXT HIGHER ASSY.				139
15:27:45	22-Jan-99	S8344135		SHEET 1 OF 1

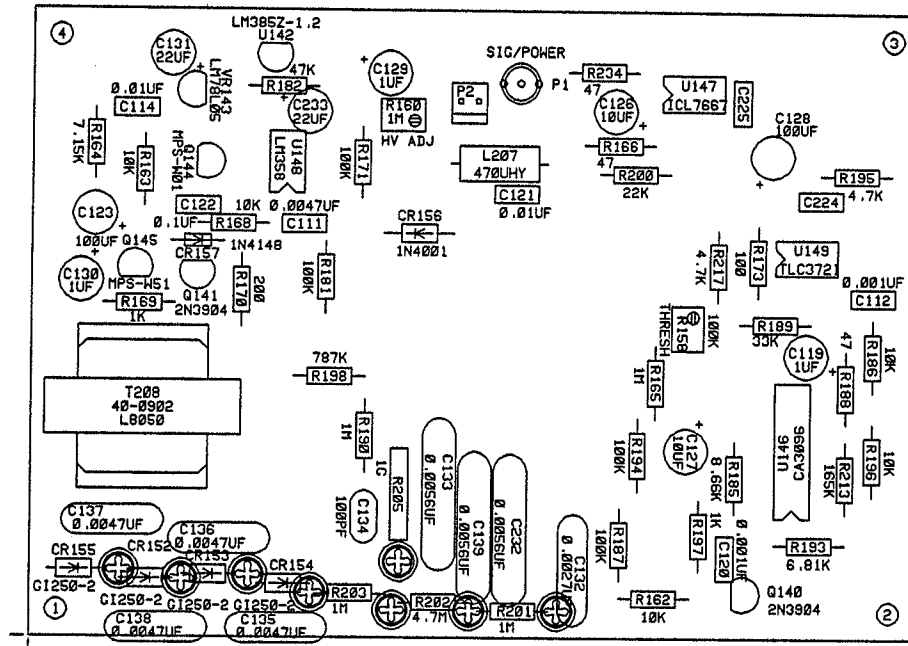

LUDLUM MEASUREMENTS INC. SHEETWATER, TX.			
DR ACF	22-SEP-98	TITLE: DETECTOR INTERFACE	
CHK	/ /	BOARD# 5344-135	BS344135
DSGN RSS	14-SEP-98	MODEL 440-7	SERIES 344 SHEET 140
APP	<i>DWS</i>	COMP ARTWORK <input type="checkbox"/>	SLDR ARTWORK <input type="checkbox"/>
14:01:51	7-Mar-02	COMP OUTLINE <input checked="" type="checkbox"/>	SLDR OUTLINE <input type="checkbox"/>
COMP PASTE <input type="checkbox"/>	COMP MASK <input type="checkbox"/>	SLDR PASTE <input type="checkbox"/>	SLDR MASK <input type="checkbox"/>

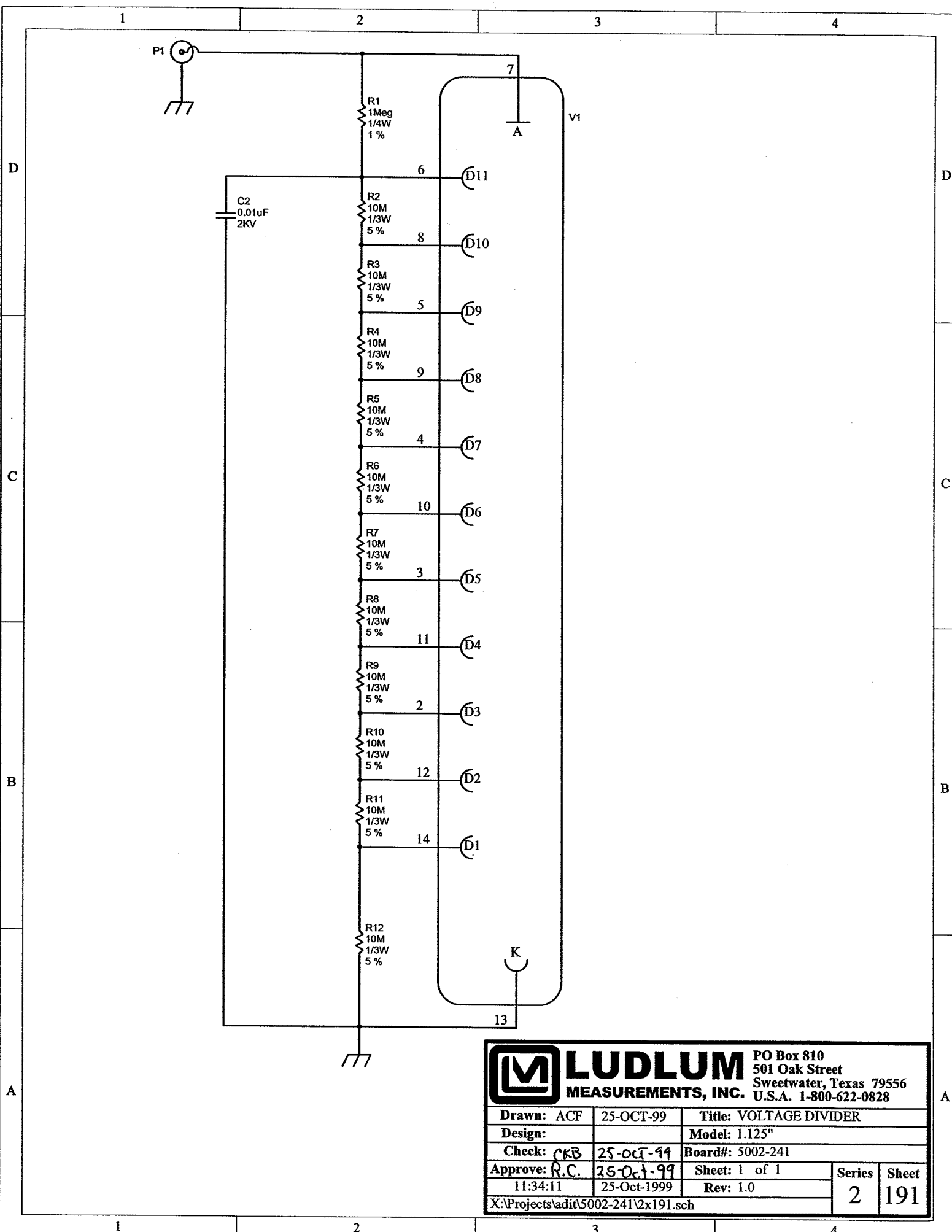

		PO Box 810 501 Oak Street Sweetwater, Texas 79556 U.S.A. 1-800-622-0828	
Drawn: ACF	25-OCT-99	Title: VOLTAGE DIVIDER	
Design:		Model: 1.125"	
Check: CKB	25-OCT-99	Board#: 5002-241	
Approve: R.C.	25-Oct-99	Sheet: 1 of 1	Series
11:34:11	25-Oct-1999	Rev: 1.0	Sheet
X:\Projects\adit\5002-241\2x191.sch			2 191

APPENDIX A

RADIATION: A Brief Explanation

Radiation in material has become a matter of growing concern. Whether the radiation is natural or artificial, the potential for injury and lost revenue in the work place exists. For any facility that takes in fugitive radiation, a potential exists for clean-up, worker injury and lawsuits.

Radiation is an energy given off by an unstable atom as it decays. Many radioactive materials, such as radium, uranium, and others occur naturally and are found in the ground. These and other sources of naturally occurring radiation make up what is commonly referred to as background radiation. This is low level radiation that is always present. We are all exposed to background radiation every day with no ill effects.

The problem, therefore, is not in detecting radiation, but detecting excessive radiation. There are many factors that have to be considered when attempting to do this.

1. Background radiation is not constant. It is continuously changing due to cosmic events, weather, and other influences.
2. The farther away from the source of radiation, the less you will be able to detect from that source. A source of a certain size will read a certain amount at one foot from the source. If you double the distance (2 feet from the source) the reading will only be 25% of that obtained at one foot.
3. The longer the time that the detectors have to look at a source the better the reading will be. For this reason the slower the vehicle passes through the system the better chance of seeing a potential source.
4. The amount of material and its density play a large part in the detector's ability to see a potential source. The more material there is between the source and the detectors, the harder it is for the detectors to see it. The higher the density, the harder it is for the detectors to see it as well.

5. The larger the detector the more sensitive it will be.
6. A well shielded detector will be able to detect smaller changes in radiation levels than an otherwise equivalent unshielded detector. By shielding the sides and back of the detectors we are able to block out a large part of the background radiation, thus increasing the sensitivity of the detector to the small changes in radiation levels caused by a source.

When taking all of the above circumstances into consideration it can be determined that the best way to monitor loads is to have large detectors as close to a lightly-packed small load that is moving through the system as slowly as possible. Another factor to consider is that the system should be able to monitor background radiation at all times and make adjustments to the alarm to keep it as close to the background as possible without causing a false alarm.

One problem for gate monitors that continuously monitor radiation comes from medical tests that use a radioactive dye or tracer. People can be released from the hospital, reading several thousand $\mu\text{R/hr}$ or less than $100\mu\text{Sv/hr}$, and set off gate monitors 100 ft. away. Another problem is that radiographers and certified welders use a powerful radiation source to check their material or welds for cracks. This radiation is powerful enough to set off gate monitors two miles away. When the gate monitor is installed would be a good time to consult your neighbors and to ask them to point their source in another direction.